

250 EXC TPI
250 EXC Six Days TPI
250 XC-W TPI
300 EXC TPI
300 EXC Six Days TPI
300 XC-W TPI
300 XC-W Six Days TPI

Art. no. 3206345en



Read this repair manual carefully and thoroughly before beginning work.

The vehicle will only be able to meet the demands placed on it if the specified service work is performed regularly and properly.

This repair manual was written to correspond to the latest state of this model series. We reserve the right to make changes in the interest of technical advancement without updating this repair manual at the same time. We shall not provide a description of general workshop methods. Likewise, safety rules that apply in a workshop are not specified here. It is assumed that the repair work will be performed by a fully trained mechanic.

All specifications are non-binding. KTM Sportmotorcycle GmbH specifically reserves the right to modify or delete technical specifications, prices, colors, forms, materials, services, designs, equipment, etc., without prior notice and without specifying reasons, to adapt these to local conditions, as well as to stop production of a particular model without prior notice. KTM accepts no liability for delivery options, deviations from figures and descriptions, misprints, and other errors. The models portrayed partly contain special equipment that does not belong to the regular scope of supply.

© 2018 KTM Sportmotorcycle GmbH, Mattighofen Austria

All rights reserved

Reproduction, even in part, as well as copying of all kinds, is permitted only with the express written permission of the copyright owner.



ISO 9001(12 100 6061)

According to the international quality management standard ISO 9001, KTM uses quality assurance processes that lead to the maximum possible quality of the products.

Issued by: TÜV Management Service

REG.NO. 12 100 6061

KTM Sportmotorcycle GmbH
Stallhofnerstraße 3
5230 Mattighofen, Austria

This document is valid for the following models:

250 EXC TPI EU (F7303S7)

250 EXC Six Days TPI EU (F7303S2)

250 XC-W TPI US (F7375S4)

300 EXC TPI EU (F7403S7)

300 EXC Six Days TPI EU (F7403S2)

300 XC-W TPI US (F7475S3)

300 XC-W Six Days TPI US (F7475S2)



TABLE OF CONTENTS

1	MEANS OF REPRESENTATION	7	6.10.8	Assembling the fork legs.....	33
1.1	Symbols used	7	6.10.9	Lubricating the steering head bearing	37
1.2	Formats used.....	7	6.10.10	Removing the lower triple clamp ...	37
2	SAFETY ADVICE.....	8	6.10.11	Installing the lower triple clamp	38
2.1	Repair Manual	8	6.10.12	Changing the steering head bearing	40
2.2	Safety advice.....	8	6.10.13	Checking the play of the steering head bearing	42
2.3	Degrees of risk and symbols.....	8	6.10.14	Adjusting the steering head bearing play	42
2.4	Work rules.....	8	6.11	All Six Days models.....	43
3	IMPORTANT NOTES.....	9	6.11.1	Servicing the fork.....	43
3.1	Manufacturer and implied warranty.....	9	6.11.2	Disassembling the fork legs	43
3.2	Operating and auxiliary substances	9	6.11.3	Disassembling the cartridge	46
3.3	Spare parts, accessories	9	6.11.4	Disassembling the tap compression	49
3.4	Figures	9	6.11.5	Checking the fork legs.....	50
4	SERIAL NUMBERS	10	6.11.6	Assembling the tap compression ...	51
4.1	Chassis number	10	6.11.7	Assembling the cartridge	52
4.2	Type label	10	6.11.8	Assembling the fork legs.....	56
4.3	Engine number	10	6.11.9	Lubricating the steering head bearing	61
4.4	Fork part number	10	6.11.10	Removing the lower triple clamp ...	61
4.5	Shock absorber article number	11	6.11.11	Installing the lower triple clamp	62
5	MOTORCYCLE	12	6.11.12	Changing the steering head bearing	64
5.1	Raising the motorcycle with a lift stand	12	6.11.13	Checking the play of the steering head bearing	65
5.2	Removing the motorcycle from the lift stand	12	6.11.14	Adjusting the steering head bearing play	66
5.3	Starting the vehicle	12	7	HANDLEBAR, CONTROLS.....	67
5.4	Starting the motorcycle to check the function	13	7.1	Handlebar position.....	67
6	FORK, TRIPLE CLAMP	14	7.2	Adjusting the handlebar position	67
6.1	Adjusting the compression damping of the fork	14	7.3	Adjusting the basic position of the clutch lever	69
6.2	Adjusting the rebound damping of the fork.....	15	7.4	Checking the rubber grip	70
6.3	Adjusting the spring preload of the fork (All Six Days models)	16	7.5	Checking throttle cable routing.....	70
6.4	Bleeding the fork legs.....	16	7.6	Checking the play in the throttle cable	71
6.5	Cleaning the dust boots of the fork legs	17	7.7	Adjusting the play in the throttle cable	71
6.6	Removing the fork legs	17	7.8	Setting the characteristic map of the throttle response	72
6.7	Installing the fork legs.....	18	8	FRAME	74
6.8	Removing the fork protector	19	8.1	Checking the frame	74
6.9	Installing the fork protector	19	8.2	Removing the engine guard (All Six Days models)	74
6.10	All standard EXC/XC-W models	20	8.3	Installing the engine guard (All Six Days models)	74
6.10.1	Servicing the fork.....	20	8.4	Changing the footrests.....	74
6.10.2	Disassembling the fork legs	20			
6.10.3	Disassembling the cartridge	23			
6.10.4	Disassembling the tap compression	26			
6.10.5	Checking the fork legs.....	27			
6.10.6	Assembling the tap compression ...	28			
6.10.7	Assembling the cartridge	29			

9	SHOCK ABSORBER, SWINGARM	78	11	AIR FILTER	116
9.1	Adjusting the high-speed compression damping of the shock absorber.....	78	11.1	Removing the air filter box cover	116
9.2	Adjusting the low-speed compression damping of the shock absorber.....	78	11.2	Installing the air filter box cover	116
9.3	Adjusting the rebound damping of the shock absorber.....	79	11.3	Removing the air filter.....	117
9.4	Measuring the rear wheel dimension unloaded.....	80	11.4	Installing the air filter.....	117
9.5	Checking the static sag of the shock absorber.....	80	11.5	Cleaning the air filter and air filter box.....	118
9.6	Checking the riding sag of the shock absorber.....	81	11.6	Preparing air filter box cover for securing.....	118
9.7	Adjusting the spring preload of the shock absorber	81	11.7	Sealing the air filter box	119
9.8	Adjusting the riding sag.....	82	12	FUEL TANK, SEAT, TRIM	120
9.9	Removing the shock absorber.....	83	12.1	Opening the filler cap.....	120
9.10	Installing the shock absorber.....	83	12.2	Closing the filler cap	120
9.11	Servicing the shock absorber.....	83	12.3	Removing the seat	121
9.12	Removing the spring.....	84	12.4	Mounting the seat.....	121
9.13	Disassembling the damper.....	85	12.5	Removing the fuel tank.....	122
9.14	Disassembling the seal ring retainer.....	86	12.6	Installing the fuel tank	123
9.15	Disassembling the piston rod	87	12.7	Changing the fuel screen	125
9.16	Replacing the pilot bushing	88	12.8	Changing the fuel filter.....	126
9.17	Checking the damper	89	12.9	Changing the fuel pump	129
9.18	Removing the heim joint.....	90	12.10	Checking the fuel pressure.....	132
9.19	Installing the heim joint.....	91	13	MASK, FENDER.....	134
9.20	Assembling seal ring retainer	91	13.1	Removing front fender.....	134
9.21	Assembling the piston rod.....	92	13.2	Installing front fender.....	134
9.22	Assembling the damper	94	13.3	Removing the headlight mask with the headlight.....	135
9.23	Bleeding and filling the damper	96	13.4	Installing the headlight mask with the headlight.....	135
9.24	Filling damper with nitrogen	99	14	WHEELS	137
9.25	Installing the spring	100	14.1	Checking the tire air pressure.....	137
9.26	Checking the swingarm.....	101	14.2	Checking the tire condition	137
9.27	Checking the heim joint for play	101	14.3	Checking the wheel bearing for play.....	138
9.28	Changing the heim joint.....	102	14.4	Checking the brake discs	139
9.29	Changing the heim joint on the swingarm	103	14.5	Checking the rim run-out	139
9.30	Checking the swingarm bearing for play.....	105	14.6	Checking spoke tension	140
9.31	Removing the swingarm.....	105	14.7	Front wheel	141
9.32	Installing the swingarm.....	106	14.7.1	Removing the front wheel	141
9.33	Changing the swingarm bearing.....	108	14.7.2	Installing the front wheel	142
10	EXHAUST.....	111	14.7.3	Changing the front brake disc	142
10.1	Removing the manifold.....	111	14.7.4	Changing front wheel bearing.....	143
10.2	Installing the manifold	112	14.8	Rear wheel	144
10.3	Removing the main silencer	113	14.8.1	Removing the rear wheel	144
10.4	Installing the main silencer.....	114	14.8.2	Installing the rear wheel	145
10.5	Changing the glass fiber yarn filling in the main silencer	114	14.8.3	Changing the rear brake disc.....	146
			14.8.4	Changing the rear wheel bearing	147
			14.8.5	Checking the chain for dirt	149
			14.8.6	Cleaning the chain.....	149
			14.8.7	Checking the chain tension.....	150

TABLE OF CONTENTS

14.8.8	Checking the chain, rear sprocket, engine sprocket, and chain guide	151	17.5	Changing the combination instrument	184
14.8.9	Adjusting the chain tension	153	17.6	Combination instrument overview ...	185
14.8.10	Changing the drivetrain kit.....	154	17.7	Activation and test	185
15	WIRING HARNESS, BATTERY.....	157	17.8	Setting the kilometers or miles.....	185
15.1	Ignition curve plug-in connector	157	17.9	Adjusting the combination instrument function.....	186
15.2	Changing the main fuse.....	157	17.10	Setting the clock.....	187
15.3	Changing the fuses of individual power consumers	159	17.11	Activating additional functions	187
15.4	Disconnecting the negative cable of the battery.....	160	17.12	Setting the wheel circumference	188
15.5	Connecting the negative cable of the battery	161	17.13	Viewing the lap time.....	188
15.6	Removing the battery	161	18	ENGINE	190
15.7	Installing the battery	162	18.1	Cleaning the pressure sensor hose ...	190
15.8	Recharging the battery	163	18.2	Removing the engine.....	190
15.9	Checking the charging voltage.....	164	18.3	Installing the engine.....	196
15.10	Checking the open-circuit current....	165	18.4	Engine disassembly.....	203
15.11	Checking the starter relay	165	18.4.1	Clamping the engine into the engine work stand	203
15.12	Diagnostics connector	166	18.4.2	Removing the shift lever	203
16	BRAKE SYSTEM	167	18.4.3	Removing the clutch push rod.....	203
16.1	Checking the front brake linings	167	18.4.4	Draining the gear oil.....	203
16.2	Changing the front brake linings.....	167	18.4.5	Removing the spacer	204
16.3	Checking the free travel of the hand brake lever	169	18.4.6	Removing the alternator cover	204
16.4	Adjusting free travel of hand brake lever (All EXC models)	170	18.4.7	Removing the kick starter	205
16.5	Adjusting the basic position of the hand brake lever (All XC-W models).....	170	18.4.8	Removing injection valves.....	205
16.6	Checking the front brake fluid level	170	18.4.9	Removing the cylinder head.....	205
16.7	Adding front brake fluid.....	171	18.4.10	Removing the cylinder.....	206
16.8	Changing the front brake fluid.....	172	18.4.11	Removing the piston	208
16.9	Checking the brake linings of the rear brake.....	174	18.4.12	Removing the water pump cover	209
16.10	Changing the rear brake linings	174	18.4.13	Removing the clutch cover.....	209
16.11	Checking the free travel of foot brake lever	176	18.4.14	Removing the clutch discs.....	210
16.12	Adjusting the basic position of the foot brake lever.....	177	18.4.15	Removing the clutch basket.....	211
16.13	Checking the rear brake fluid level	178	18.4.16	Removing the balancer shaft.....	212
16.14	Adding rear brake fluid	178	18.4.17	Removing the kick starter shaft ...	213
16.15	Changing the rear brake fluid	179	18.4.18	Removing the intermediate kick starter gear.....	213
17	LIGHTING SYSTEM, INSTRUMENTS	182	18.4.19	Removing the shift shaft.....	214
17.1	Changing the headlight bulb	182	18.4.20	Removing the shift drum locating unit.....	214
17.2	Changing the turn signal bulb (All EXC models).....	182	18.4.21	Removing the locking lever	214
17.3	Checking the headlight setting	183	18.4.22	Removing the rotor.....	214
17.4	Adjusting the headlight range.....	184	18.4.23	Removing the starter motor.....	215
			18.4.24	Removing the reed valve housing.....	216
			18.4.25	Removing the left engine case section	217
			18.4.26	Removing the shift rails.....	217
			18.4.27	Removing the shift drum	217
			18.4.28	Removing the shift forks.....	218
			18.4.29	Removing the transmission shafts	218
			18.4.30	Removing the crankshaft	218









18.5	Working on individual parts.....	219	18.6.6	Installing the left engine case section	252
18.5.1	Working on the right section of the engine case	219	18.6.7	Installing the reed valve housing.....	253
18.5.2	Working on the left section of the engine case	220	18.6.8	Installing the starter motor.....	254
18.5.3	Removing the crankshaft bearing inner race	222	18.6.9	Installing the rotor	255
18.5.4	Installing the crankshaft bearing inner race	222	18.6.10	Installing the locking lever.....	255
18.5.5	Changing the connecting rod, conrod bearing, and crank pin.....	223	18.6.11	Installing the shift drum locating unit.....	256
18.5.6	Checking the crankshaft run-out at the bearing pin	224	18.6.12	Installing the shift shaft	256
18.5.7	Checking/measuring the cylinder	224	18.6.13	Installing the intermediate kick starter gear.....	256
18.5.8	Cleaning the pressure sensor cylinder connection.....	225	18.6.14	Installing the kick starter shaft....	256
18.5.9	Removing the exhaust control	225	18.6.15	Installing the balancer shaft.....	257
18.5.10	Checking the exhaust control	227	18.6.16	Installing the clutch basket.....	258
18.5.11	Installing the exhaust control	229	18.6.17	Installing the clutch discs.....	259
18.5.12	Cylinder - Nikasil® coating	232	18.6.18	Installing the clutch cover	261
18.5.13	Checking/measuring the piston....	232	18.6.19	Installing the water pump cover	263
18.5.14	Checking the piston ring end gap.....	233	18.6.20	Installing the piston	264
18.5.15	Measuring the piston/cylinder mounting clearance.....	233	18.6.21	Installing the cylinder.....	265
18.5.16	Disassemble the reed valve housing.....	234	18.6.22	Checking the X-distance	267
18.5.17	Checking the reed valve housing, reed valve and intake flange.....	235	18.6.23	Adjusting the X-distance.....	267
18.5.18	Assemble the reed valve housing.....	235	18.6.24	Adjusting the Z-distance.....	269
18.5.19	Working on the clutch cover.....	237	18.6.25	Installing the cylinder head.....	271
18.5.20	Checking the clutch	240	18.6.26	Installing injection valves	272
18.5.21	Preassembling shift shaft	241	18.6.27	Installing the kick starter	272
18.5.22	Checking the shift mechanism	242	18.6.28	Installing the alternator cover.....	272
18.5.23	Disassembling the main shaft	243	18.6.29	Installing the spacer.....	273
18.5.24	Disassembling the countershaft.....	244	18.6.30	Installing the gear oil drain plug	273
18.5.25	Checking the transmission	244	18.6.31	Installing the clutch push rod	274
18.5.26	Assembling the main shaft.....	246	18.6.32	Installing the shift lever.....	274
18.5.27	Assembling the countershaft.....	246	18.6.33	Removing the engine from the engine work stand.....	274
18.5.28	Checking the kick starter	248	19	CLUTCH	275
18.5.29	Preassembling the kick starter shaft.....	248	19.1	Checking/correcting the fluid level of the hydraulic clutch.....	275
18.5.30	Checking the electric starter drive.....	249	19.2	Changing the hydraulic clutch fluid	276
18.6	Engine assembly	250	19.3	Checking the clutch	277
18.6.1	Installing the crankshaft	250	20	WATER PUMP, COOLING SYSTEM	286
18.6.2	Installing the transmission shafts	251	20.1	Cooling system	286
18.6.3	Installing the shift forks.....	251	20.2	Checking the antifreeze and coolant level	286
18.6.4	Installing the shift drum	252	20.3	Checking the coolant level	287
18.6.5	Installing the shift rails	252	20.4	Draining the coolant	287
			20.5	Refilling with coolant	288
			21	EXHAUST CONTROL	291
			21.1	Checking/adjusting the exhaust control	291

TABLE OF CONTENTS

22	LUBRICATION SYSTEM.....	294	27	CLEANING, CARE	322
22.1	Changing the gear oil.....	294	27.1	Cleaning the motorcycle	322
22.2	Checking the gear oil level	295	27.2	Checks and maintenance steps for winter operation.....	323
22.3	Adding gear oil	295	28	STORAGE.....	324
22.4	Checking 2-stroke oil level	296	28.1	Storage	324
22.5	Opening 2-stroke oil tank cap.....	297	28.2	Preparing for use after storage.....	325
22.6	Adding 2-stroke oil.....	297	29	SERVICE SCHEDULE	326
22.7	Closing 2-stroke oil tank cap	297	29.1	Additional information	326
22.8	Priming the oil pump.....	298	29.2	Required work	326
22.9	Replacing the oil pump	299	29.3	Recommended work	327
23	IGNITION SYSTEM.....	302	30	WIRING DIAGRAM	330
23.1	Checking the ignition system.....	302	30.1	Page 1 of 8 (All EXC models)	330
23.2	Ignition coil - checking the primary winding.....	303	30.2	Page 2 of 8 (All EXC models)	332
23.3	Checking the spark plug connector	304	30.3	Page 3 of 8 (All EXC models)	334
23.4	Alternator – checking the stator winding.....	304	30.4	Page 4 of 8 (All EXC models)	336
23.5	Checking the crankshaft position sensor.....	305	30.5	Page 5 of 8 (All EXC models)	338
23.6	Changing the spark plug	306	30.6	Page 6 of 8 (All EXC models)	340
23.7	Changing the spark plug and spark plug connector.....	307	30.7	Page 7 of 8 (All EXC models)	342
23.8	Removing the stator	307	30.8	Page 8 of 8 (All EXC models)	344
23.9	Installing the stator	308	30.9	Page 1 of 6 (All XC-W models)	346
24	ELECTRIC STARTER	309	30.10	Page 2 of 6 (All XC-W models)	348
24.1	Checking the starter motor	309	30.11	Page 3 of 6 (All XC-W models)	350
25	THROTTLE VALVE BODY	310	30.12	Page 4 of 6 (All XC-W models)	352
25.1	Adjusting the idle speed	310	30.13	Page 5 of 6 (All XC-W models)	354
25.2	Programming ambient pressure	310	30.14	Page 6 of 6 (All XC-W models)	356
25.3	Cold start button.....	311	31	SUBSTANCES	358
26	TECHNICAL DATA.....	312	32	AUXILIARY SUBSTANCES	360
26.1	Engine	312	33	SPECIAL TOOLS	362
26.1.1	All 250 models.....	312	34	STANDARDS	377
26.1.2	All 300 models.....	312	35	INDEX OF SPECIAL TERMS	378
26.2	Tolerance, engine wear limits	313	36	LIST OF ABBREVIATIONS.....	379
26.3	Engine tightening torques	314	INDEX.....		380
26.4	Capacities	315			
26.4.1	Gear oil.....	315			
26.4.2	Engine oil	315			
26.4.3	Coolant.....	315			
26.4.4	Fuel	316			
26.5	Chassis	316			
26.6	Electrical system.....	317			
26.7	Tires.....	317			
26.8	Fork.....	317			
26.8.1	All standard EXC/XC-W models....	317			
26.8.2	All Six Days models.....	318			
26.9	Shock absorber	318			
26.10	Chassis tightening torques	319			

1.1 Symbols used

The meaning of specific symbols is described below.

	Indicates an expected reaction (e.g. of a work step or a function).
	Indicates an unexpected reaction (e.g. of a work step or a function).
	Indicates a page reference (more information is provided on the specified page).
	Indicates information with more details or tips.
	Indicates the result of a testing step.
	Indicates a voltage measurement.
	Indicates a current measurement.
	Indicates a resistance measurement.
	Indicates the end of an activity including potential rework.

1.2 Formats used

The typographical formats used in this document are explained below.

Proprietary name	Indicates a proprietary name.
Name®	Indicates a protected name.
Brand™	Indicates a brand available on the open market.
<u>Underlined terms</u>	Refer to technical details of the vehicle or indicate technical terms, which are explained in the glossary.

2.1 Repair Manual

Read this Repair Manual carefully and thoroughly before beginning work. It contains useful information and tips that will help you repair and maintain your vehicle.

This manual assumes that the necessary special KTM tools and KTM workplace and workshop equipment are available.

2.2 Safety advice

A number of safety instructions need to be followed to operate the product described safely. Therefore read this instruction and all further instructions included carefully. The safety instructions are highlighted in the text and are referred to at the relevant passages.



Info

Various information and warning labels are attached in prominent locations on the product described. Do not remove any information or warning labels. If they are missing, you or others may not recognize dangers and may therefore be injured.

2.3 Degrees of risk and symbols



Danger

Identifies a danger that will immediately and invariably lead to fatal or serious permanent injury if the appropriate measures are not taken.



Warning

Identifies a danger that is likely to lead to fatal or serious injury if the appropriate measures are not taken.



Caution

Identifies a danger that may lead to minor injuries if the appropriate measures are not taken.

Note

Identifies a danger that will lead to considerable machine and material damage if the appropriate measures are not taken.



Note

Indicates a danger that will lead to environmental damage if the appropriate measures are not taken.

2.4 Work rules

Special tools are necessary for certain tasks. The tools are not a component of the vehicle, but can be ordered using the number in parentheses. Example: bearing puller (15112017000)

During assembly, use new parts to replace parts which cannot be reused (e.g. self-locking screws and nuts, seals, sealing rings, O-rings, pins, and lock washers).

In the case of certain screws, a thread locker (e.g. **Loctite**[®]) is required. Apply according to the manufacturer's instructions.

After disassembly, clean the parts that are to be reused and check them for damage and wear. Change damaged or worn parts.

After completing a repair or service work, check the operating safety of the vehicle.

3.1 Manufacturer and implied warranty

The work specified in the service schedule may only be performed in an authorized KTM workshop and must be recorded in both the Service & Warranty Booklet and in **KTM Dealer.net**, otherwise any warranty coverage will become void. Damage or secondary damage caused by tampering with and/or conversions on the vehicle are not covered by the warranty.

Additional information on the manufacturer or implied warranty and the procedures involved can be found in the Service & Warranty Booklet.

3.2 Operating and auxiliary substances



Note

Environmental hazard Improper handling of fuel is a danger to the environment.

- Do not allow fuel to enter the groundwater, the soil, or the sewage system.

Use operating and auxiliary substances in accordance with the Owner's Manual and specification.

3.3 Spare parts, accessories

Only use spare parts and accessories approved and/or recommended by KTM. KTM accepts no liability for other products and any resulting damage or loss.

The current **KTM PowerParts** for your vehicle can be found on the KTM website.

International KTM Website: <http://www.ktm.com>

3.4 Figures

The figures contained in the manual may depict special equipment.

In the interest of clarity, some components may be shown disassembled or may not be shown at all. It is not always necessary to disassemble the component to perform the activity in question. Please follow the instructions in the text.

4 SERIAL NUMBERS

4.1 Chassis number

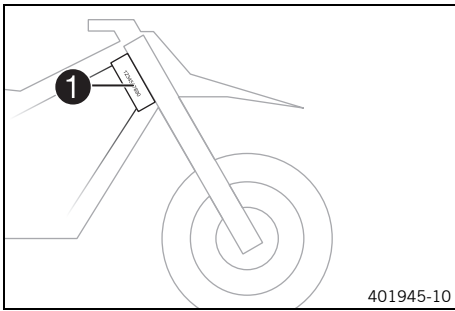

The chassis number **1** is stamped on the right side of the steering head.

4.2 Type label

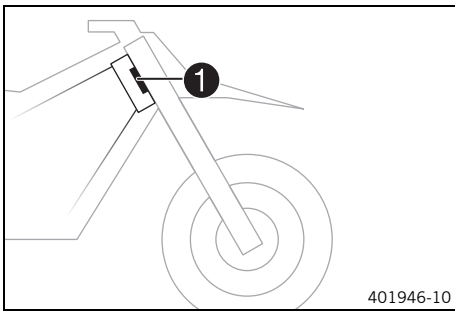

Type label **1** is fixed to the front of the steering head.

4.3 Engine number

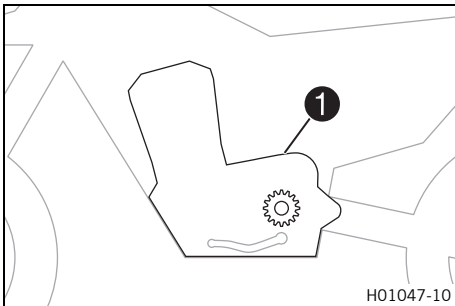

The engine number **1** is located on the left side of the engine over the engine sprocket.

4.4 Fork part number

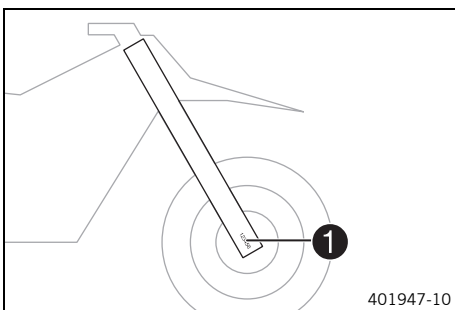

The fork part number **1** is stamped on the inside of the axle clamp.

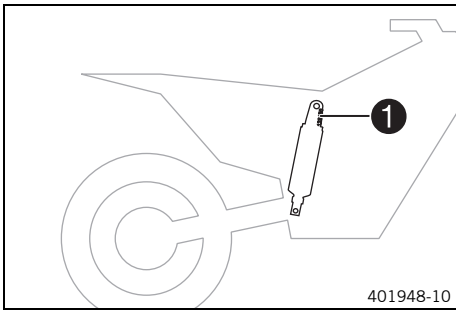
4.5 Shock absorber article number

Shock absorber article number **1** is stamped on the top of the shock absorber above the adjusting ring towards the engine side.

401948-10

5.1 Raising the motorcycle with a lift stand

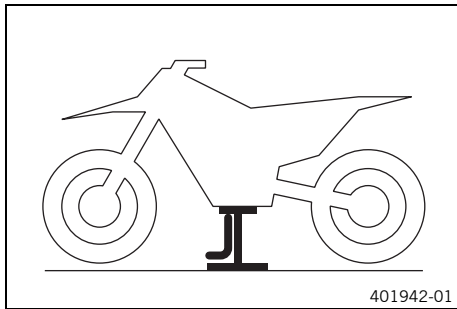

Note

Danger of damage The parked vehicle can roll away or fall over.

- Park the vehicle on a firm and level surface.
- Raise the motorcycle at the frame underneath the engine.

Lift stand (78129955100) (🗨️ p. 370)

- ✓ Neither wheel is in contact with the ground.
- Secure the motorcycle against falling over.

5.2 Removing the motorcycle from the lift stand

Note

Danger of damage The parked vehicle can roll away or fall over.

- Park the vehicle on a firm and level surface.

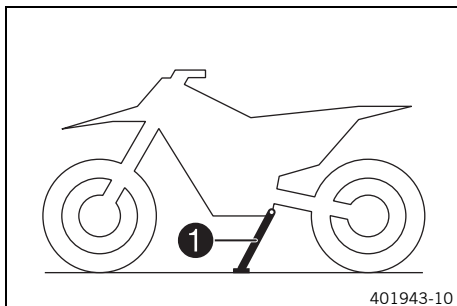

- Remove the motorcycle from the lift stand.
- Remove the lift stand.
- To park the motorcycle, press side stand ① to the ground with your foot and lean the motorcycle on it.

Info

When you are riding, the side stand must be folded up and secured with the rubber band.

5.3 Starting the vehicle



Danger

Danger of poisoning Exhaust gases are toxic and inhaling them may result in unconsciousness and death.

- Always make sure there is sufficient ventilation when running the engine.
- Use an effective exhaust extraction system when starting or running the engine in an enclosed space.

Note

Engine damage High revving speed with a cold engine negatively impacts the lifespan of the engine.

- Always run the engine warm at a low speed.

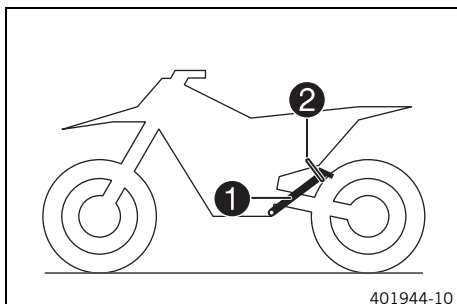

- Take the motorcycle off side stand ① and secure the side stand with rubber band ②.
- Shift gear to neutral.

Condition

Ambient temperature: < 10 °C (< 50 °F)

- Pull the cold start button fully out and turn it by a ¼ turn.



Info

If the engine is warm, the cold start button must be deactivated.

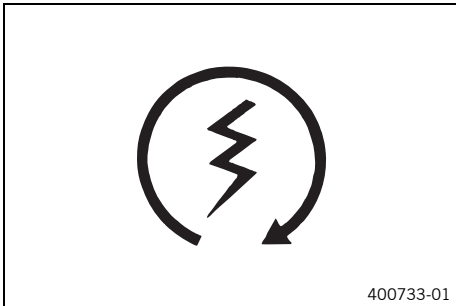

- Press the electric starter button or push the kick starter robustly through its full range.



Info

Do not open the throttle.

Press the electric starter button for a maximum of 5 seconds. Wait for 30 seconds before a further attempt at starting.

At temperatures below 15 °C (60 °F), several attempts at starting may be necessary to warm-up the lithium-ion battery and thereby increase the starting power.

During the starting process, the malfunction indicator lamp lights up.

5.4 Starting the motorcycle to check the function



Danger

Danger of poisoning Exhaust gases are toxic and inhaling them may result in unconsciousness and death.

- Always make sure there is sufficient ventilation when running the engine.
- Use an effective exhaust extraction system when starting or running the engine in an enclosed space.

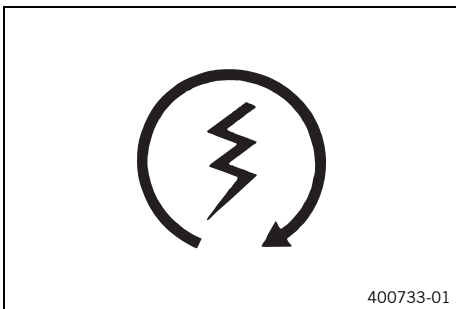

- Shift gear to neutral.
- Press the electric starter button or push the kick starter robustly through its full range.



Info

Press the electric starter button for a maximum of 5 seconds. Wait for 30 seconds before a further attempt at starting.

At temperatures below 15 °C (60 °F), several attempts at starting may be necessary to warm-up the lithium-ion battery and thereby increase the starting power.

During the starting process, the malfunction indicator lamp lights up.

Do not open the throttle.

6.1 Adjusting the compression damping of the fork

i Info

The hydraulic compression damping determines the fork suspension behavior.

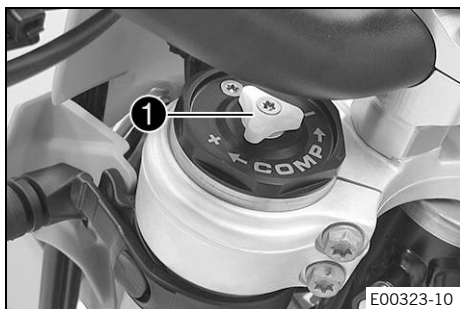

(All standard EXC/XC-W models)

- Turn white adjusting screw **1** clockwise as far as it will go.

i Info

Adjusting screw **1** is located at the upper end of the left fork leg. The compression damping is located in left fork leg **COMP** (white adjusting screw). The rebound damping is located in right fork leg **REB** (red adjusting screw).

- Turn counterclockwise by the number of clicks corresponding to the fork type.

Guideline

Compression damping	
Comfort	18 clicks
Standard	15 clicks
Sport	12 clicks

i Info

Turn clockwise to increase damping; turn counterclockwise to reduce damping.

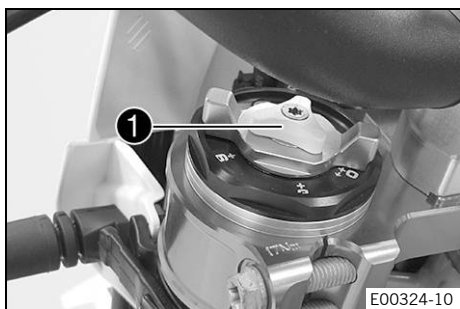

(All Six Days models)

- Turn white adjusting screw **1** clockwise as far as it will go.

i Info

Adjusting screw **1** is located at the upper end of the left fork leg. The compression damping is located in left fork leg **COM** (white adjusting screw). The rebound damping is located in right fork leg **REB** (red adjusting screw).

- Turn counterclockwise by the number of clicks corresponding to the fork type.

Guideline

Compression damping	
Comfort	18 clicks
Standard	15 clicks
Sport	12 clicks

i Info

Turn clockwise to increase damping; turn counterclockwise to reduce damping.

6.2 Adjusting the rebound damping of the fork

i Info

The hydraulic rebound damping determines the fork suspension behavior.



E00326-10

(All standard EXC/XC-W models)

- Turn red adjusting screw **1** clockwise as far as it will go.

i Info

Adjusting screw **1** is located at the upper end of the right fork leg.

The rebound damping is located in right fork leg **REB** (red adjusting screw). The compression damping is located in left fork leg **COMP** (white adjusting screw).

- Turn counterclockwise by the number of clicks corresponding to the fork type.

Guideline

Rebound damping	
Comfort	18 clicks
Standard	15 clicks
Sport	12 clicks

i Info

Turn clockwise to increase damping; turn counterclockwise to reduce damping.

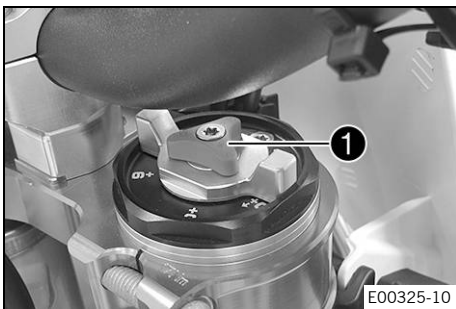

E00325-10

(All Six Days models)

- Turn red adjusting screw **1** clockwise as far as it will go.

i Info

Adjusting screw **1** is located at the upper end of the right fork leg.

The rebound damping is located in right fork leg **REB** (red adjusting screw). The compression damping is located in left fork leg **COM** (white adjusting screw).

- Turn counterclockwise by the number of clicks corresponding to the fork type.

Guideline

Rebound damping	
Comfort	18 clicks
Standard	15 clicks
Sport	12 clicks

i Info

Turn clockwise to increase damping; turn counterclockwise to reduce damping.

6.3 Adjusting the spring preload of the fork (All Six Days models)

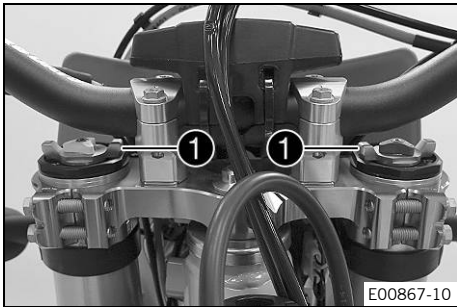

Preparatory work

- Raise the motorcycle with a lift stand. (📖 p. 12)

Main work

- Turn the adjusting wings ❶ counterclockwise all the way.
 - ✓ The marking **+0** aligns with the adjusting wing on both fork legs.



Info

Make the adjustment by hand only. Do not use a tool. Make the same adjustment on both fork legs.

- Turn the adjusting wings clockwise.

Guideline

Spring preload - Preload Adjuster	
Comfort	+0
Standard	+0
Sport	+3

- ✓ The adjusting wings engage noticeably at the numerical values.



Info

Adjust the spring preload to the numerical values only as the preload will not engage between the numerical values.

Turn clockwise to increase the spring preload; turn counterclockwise to reduce the spring preload.

Adjusting the spring preload has no influence on the absorption setting of the rebound.

Basically, however, you should set the rebound damping higher with a higher spring preload.

Finishing work

- Remove the motorcycle from the lift stand. (📖 p. 12)

6.4 Bleeding the fork legs

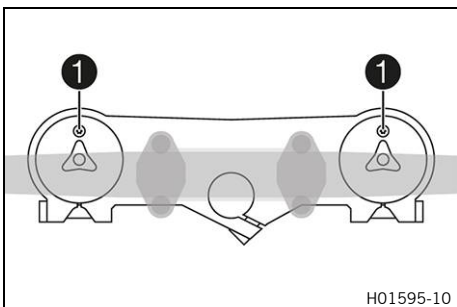

Preparatory work

- Raise the motorcycle with a lift stand. (📖 p. 12)

Main work

- Release bleeder screws ❶.
 - ✓ Any excess pressure escapes from the interior of the fork.
- Tighten the bleeder screws.

Finishing work

- Remove the motorcycle from the lift stand. (📖 p. 12)

6.5 Cleaning the dust boots of the fork legs



Preparatory work

- Raise the motorcycle with a lift stand. (📖 p. 12)
- Remove the fork protector. (📖 p. 19)

Main work

- Push dust boots ① of both fork legs downward.



Info

The dust boots remove dust and coarse dirt particles from the inside fork tubes. Over time, dirt can accumulate behind the dust boots. If this dirt is not removed, the oil seals behind can start to leak.



Warning

Danger of accidents Oil or grease on the brake discs reduces the braking effect.

- Always keep the brake discs free of oil and grease.
- Clean the brake discs with brake cleaner when necessary.

- Clean and oil the dust boots and inner fork tubes of both fork legs.

Universal oil spray (📖 p. 361)

- Press the dust boots back into their installation position.
- Remove excess oil.

Finishing work

- Install the fork protector. (📖 p. 19)
- Remove the motorcycle from the lift stand. (📖 p. 12)



6.6 Removing the fork legs

Preparatory work

- Raise the motorcycle with a lift stand. (📖 p. 12)
- Remove the front wheel. (📖 p. 141)
- Remove the headlight mask with the headlight. (📖 p. 135)

Main work

- Remove screws ① and take off the clamp.
- Remove the cable tie.
- Remove screws ② and take off the brake caliper.
- Allow the brake caliper and brake line to hang loosely to the side.

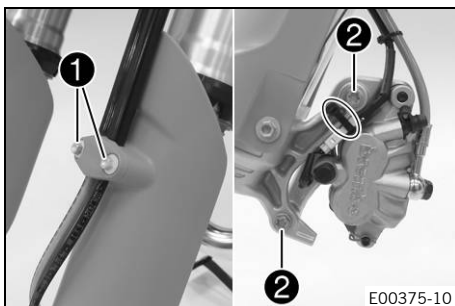

6 FORK, TRIPLE CLAMP

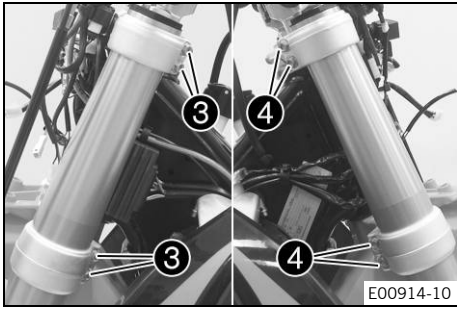

(All standard EXC/XC-W models)

- Loosen screws ③. Remove the left fork leg.
- Loosen screws ④. Remove the right fork leg.

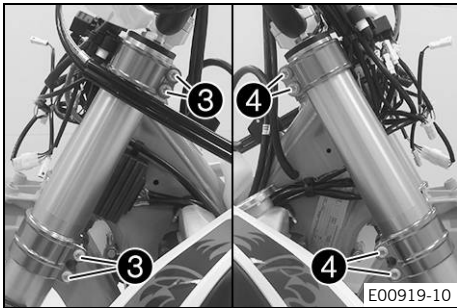

(All Six Days models)

- Loosen screws ③. Remove the left fork leg.
- Loosen screws ④. Remove the right fork leg.

6.7 Installing the fork legs

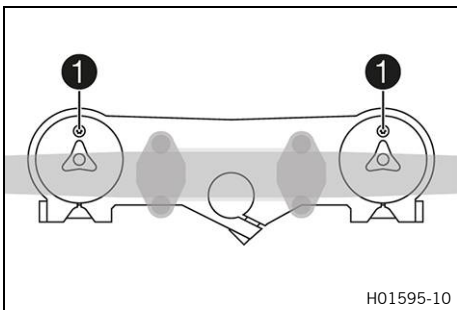

Main work

- Position the fork legs.
- ✓ Bleeder screws ① are positioned toward the front.



Info

The rebound damping is located in right fork leg **REB** (red adjusting screw). The compression damping is located in left fork leg **COM** (white adjusting screw). Grooves are milled into the side of the upper end of the fork legs. The second milled groove (from the top) must be flush with the top edge of the upper triple clamp.

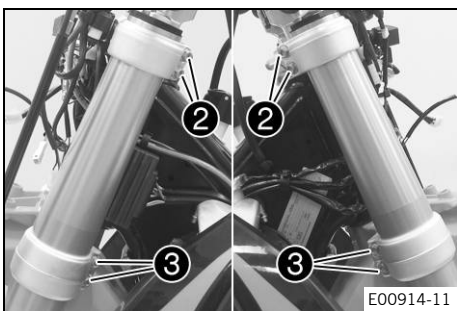

(All standard EXC/XC-W models)

- Tighten screws ②.

Guideline

Screw, top triple clamp	M8	20 Nm (14.8 lbf ft)
-------------------------	----	------------------------

- Tighten screws ③.

Guideline

Screw, bottom triple clamp	M8	15 Nm (11.1 lbf ft)
----------------------------	----	------------------------

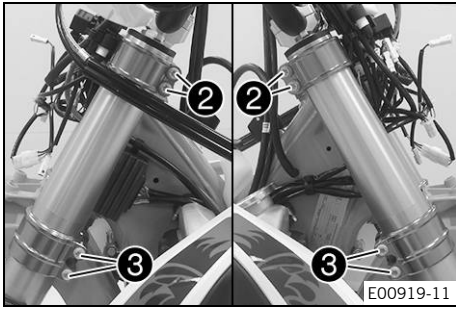

(All Six Days models)

- Tighten screws **2**.

Guideline

Screw, top triple clamp	M8	17 Nm (12.5 lbf ft)
-------------------------	----	------------------------

- Tighten screws **3**.

Guideline

Screw, bottom triple clamp	M8	15 Nm (11.1 lbf ft)
----------------------------	----	------------------------

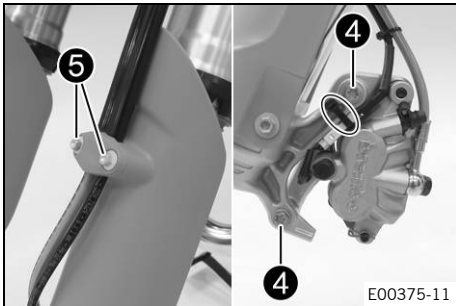

- Position the brake caliper, and mount and tighten screws **4**.

Guideline

Screw, front brake caliper	M8	25 Nm (18.4 lbf ft) Loctite®243™
----------------------------	----	--

- Mount the cable tie(s).
- Position the brake line, wiring harness, and clamp. Mount and tighten screws **5**.

Finishing work

- Install the front wheel. (📖 p. 142)
- Install the headlight mask with the headlight. (📖 p. 135)
- Check the headlight setting. (📖 p. 183)

6.8 Removing the fork protector

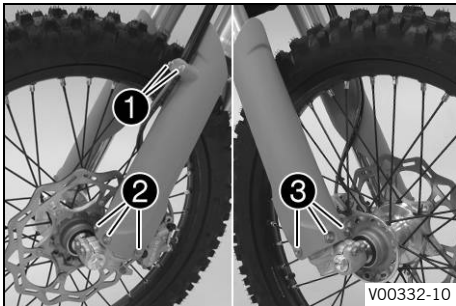

- Remove screws **1** and take off the clamp.
- Remove screws **2** and take off the left fork protector.
- Remove screws **3** and take off the right fork protector.

6.9 Installing the fork protector

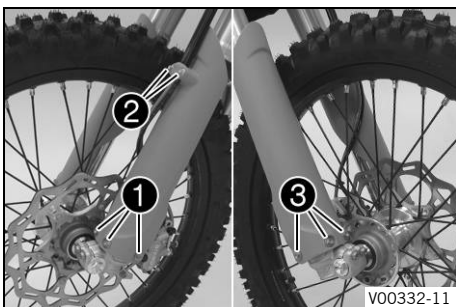

- Position the fork protector on the left fork leg. Mount and tighten screws **1**.

Guideline

Remaining screws, chassis	M6	10 Nm (7.4 lbf ft)
---------------------------	----	--------------------

- Position the brake line, wiring harness, and clamp. Mount and tighten screws **2**.
- Position the fork protector on the right fork leg. Mount and tighten screws **3**.

Guideline

Remaining screws, chassis	M6	10 Nm (7.4 lbf ft)
---------------------------	----	--------------------

6.10 All standard EXC/XC-W models

6.10.1 Servicing the fork

Condition

The fork legs have been removed.

- Disassemble the fork legs. (📖 p. 20)
- Disassemble the cartridge. (📖 p. 23)
- Check the fork legs. (📖 p. 27)
- Assemble the cartridge. (📖 p. 29)
- Assemble the fork legs. (📖 p. 33)

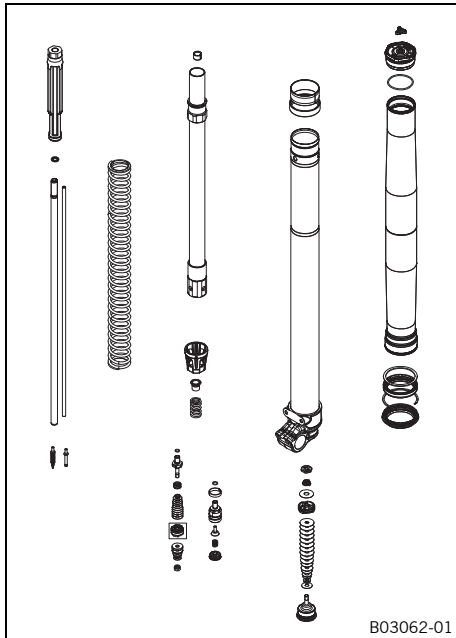

6.10.2 Disassembling the fork legs

Info

The operations are the same on both fork legs.

Condition

The fork legs have been removed.

- Note down the current state of compression damping **1 COMP** (white adjuster on the left fork leg).
- Note down the current state of rebound damping **2 REB** (red adjuster on the right fork leg).
- Open the adjusters of the rebound and compression damping completely.

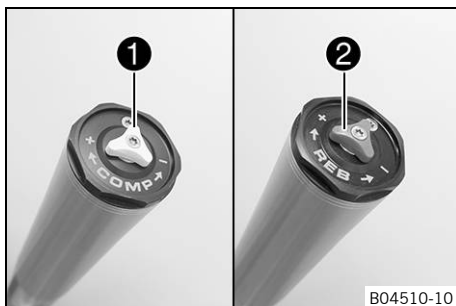



- Clamp the fork leg in the area of the lower triple clamp.

Clamping stand (T1403S) (📖 p. 374)

- Remove screw ③. Remove adjuster.

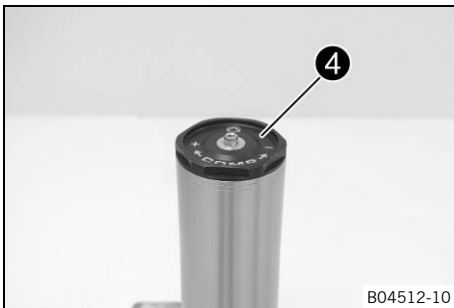

- Loosen the screw cover ④.

Ring wrench (T14017) (📖 p. 374)



Info

The screw cover cannot be removed yet.

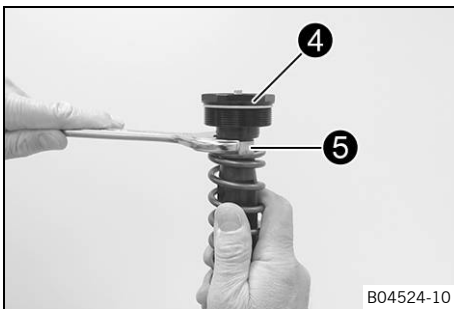

- Extract the fork leg and push the outer tube downward.
- Pull the spring downward and push the open end wrench onto hexagonal part ⑤.
- Hold the hexagonal part and loosen screw cap ④, but do not take it off yet.

Ring wrench (T14017) (📖 p. 374)



- Pull the spring downward. Remove the open end wrench.
- Remove the screw cap.

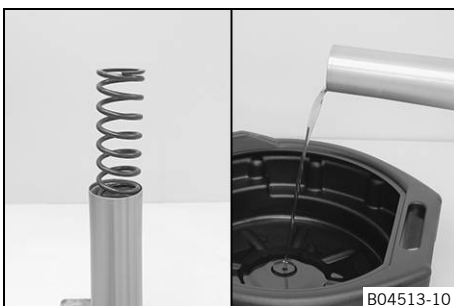

- Remove the spring.
- Drain the fork oil.



Info

Pull out and push in the piston rod a few times to pump the cartridge empty.

6 FORK, TRIPLE CLAMP

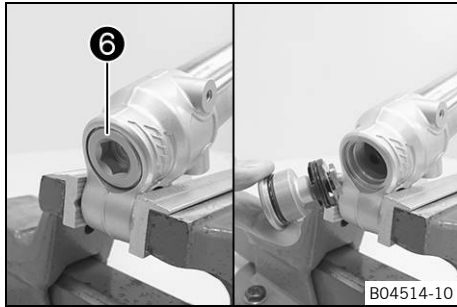

- Clamp the fork leg with the axle clamp.

Guideline

Use soft jaws.

- Unscrew and remove compression holder (6).



Info

Place a container underneath as oil will run out in most cases.

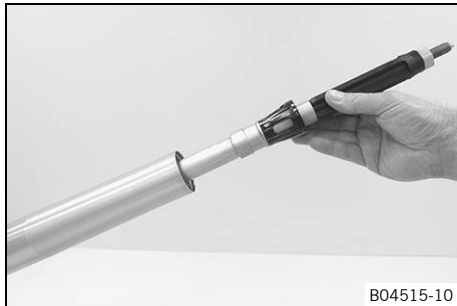

- Remove the cartridge.

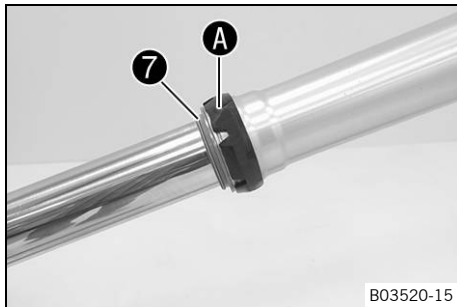

- Remove dust boot (7).
- Remove fork protector ring (A).



Info

The fork protector ring does not necessarily need to be removed for repair work.

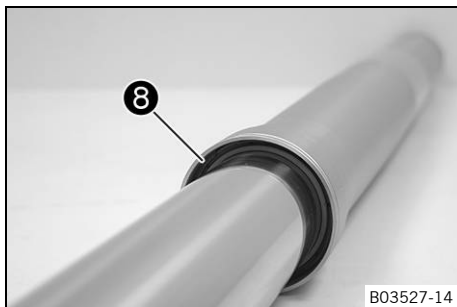

- Remove lock ring (8).



Info

The lock ring has a beveled end where a screwdriver can be applied.

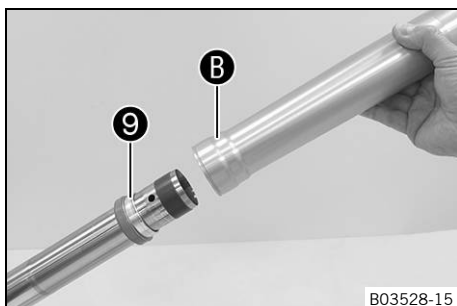

- Warm up the outer tube in area (B) of the lower sliding bushing.

Guideline

50 °C (122 °F)

- Pull the outer tube from the inner tube with a jerk.



Info

Lower sliding bushing (9) must be pulled from its bearing seat.

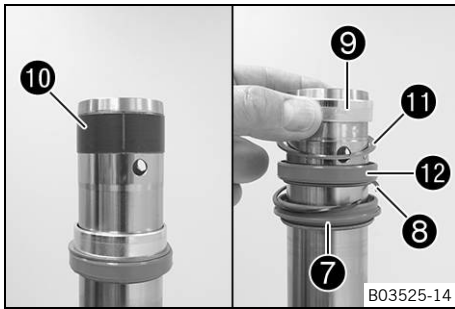

- Remove upper sliding bushing 10.

i Info
Without using a tool, pull the stack slightly apart by hand.

- Take off lower sliding bushing 9.
- Take off support ring 11.
- Take off seal ring 12.
- Take off lock ring 8.
- Take off dust boot 7.
- Unclamp the fork leg.



6.10.3 Disassembling the cartridge

Preparatory work

- Disassemble the fork legs. (📖 p. 20)

Right cartridge

- Clamp the piston rod with the special tool.

Clamping stand (T14016S) (📖 p. 374)

- Remove adjusting tube 1.
- Remove fluid barrier 2 from the piston rod.

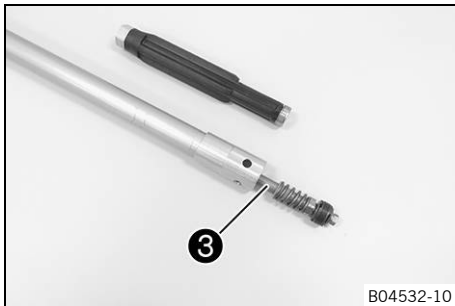
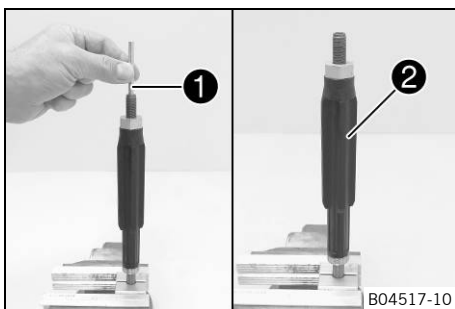

- Take piston rod 3 out of the cartridge.

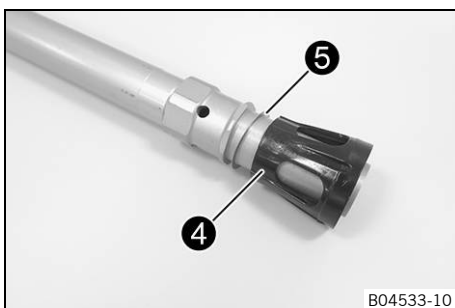

- Take spring seat 4 and washer 5 off of the cartridge.

6 FORK, TRIPLE CLAMP



- Degrease the piston rod.
- Clamp the piston rod with the special tool.

Clamping stand (T14016S) (📖 p. 374)

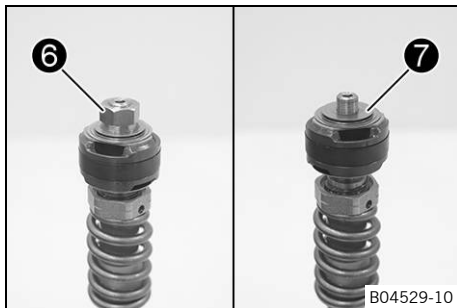

- Remove nut 6.
- Completely remove shim stack 7.

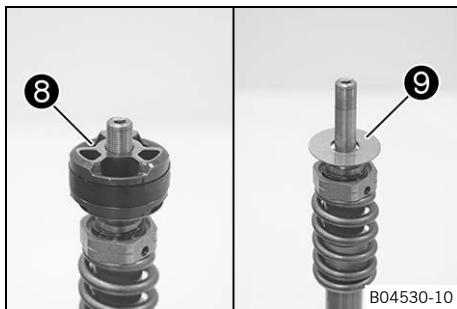

- Remove piston 8.
- Completely remove shim stack 9.

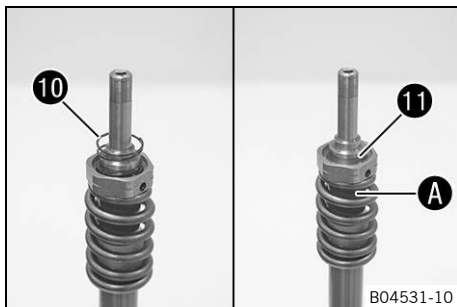

- Remove spring 10.
- Warm up the piston rod in area A.

Guideline

50 °C (122 °F)

- Remove tap rebound 11.

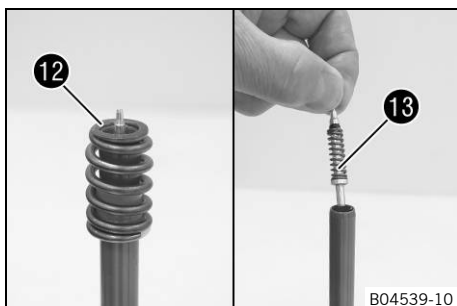

- Remove spring 12.
- Remove valve 13 of the rebound damping with the spring.
- Unclamp the piston rod.

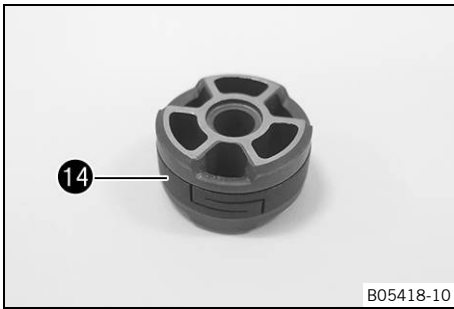

- Remove piston ring **14**.

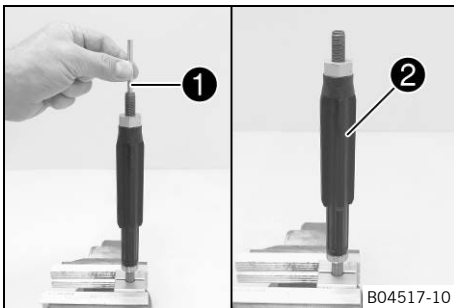

Left cartridge

- Clamp the piston rod with the special tool.
Clamping stand (T14016S) (📖 p. 374)
- Remove adjusting tube **1**.
- Remove fluid barrier **2** from the piston rod.

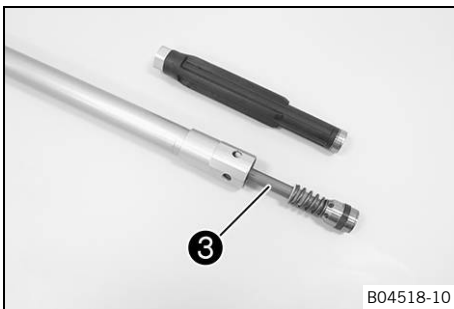

- Take piston rod **3** out of the cartridge.

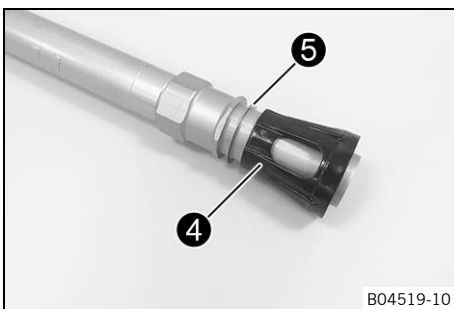

- Take spring seat **4** and washer **5** off of the cartridge.

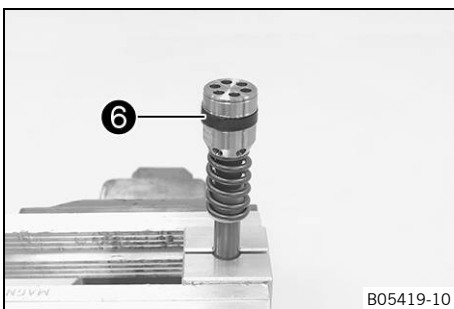

- Degrease the piston rod.
- Clamp the piston rod with the special tool.
Clamping stand (T14016S) (📖 p. 374)
- Remove piston ring **6**.

6 FORK, TRIPLE CLAMP

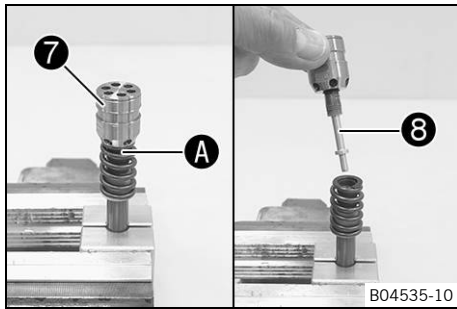

- Warm up the piston rod in area **A**.

Guideline

50 °C (122 °F)

- Remove piston **7** with setting needle **8**.

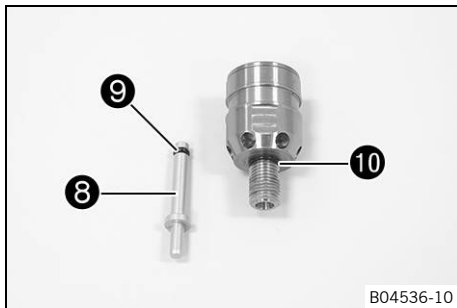

- Pull setting needle **8** out of the piston.
- Remove O-rings **9** and **10**.

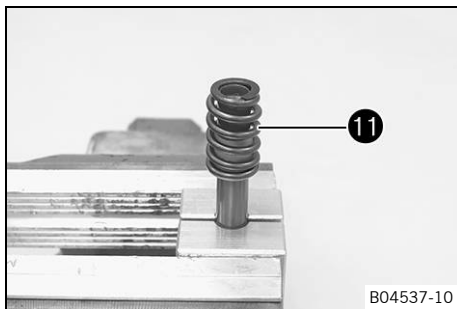

- Remove spring **11**.
- Unclamp the piston rod.

6.10.4 Disassembling the tap compression



Info

The procedures are the same on both fork legs.

Preparatory work

- Disassemble the fork legs. (🗨️ p. 20)

Main work

- Mount the tap compression on a suitable hexagon socket and clamp into a vise.
- Remove nut **1**.
- Remove spring **2**.
- Remove washer **3**.

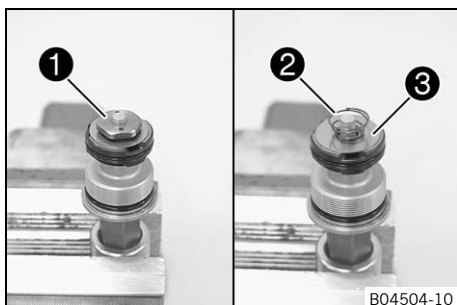

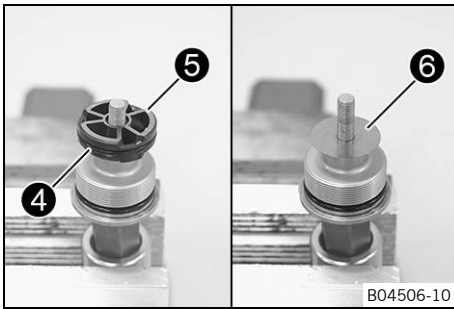

- Remove O-ring ④.
- Remove piston ⑤.
- Remove shim stack ⑥.

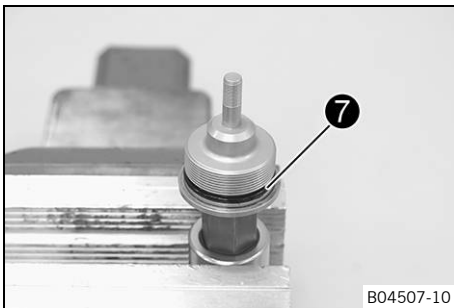

- Remove O-ring ⑦ from the tap compression.
- Extract the tap compression.

6.10.5 Checking the fork legs

Condition

The fork legs have been disassembled.



- Check the inner tube and the axle clamp for damage.
 - » If damage is found:
 - Change the inner tube.

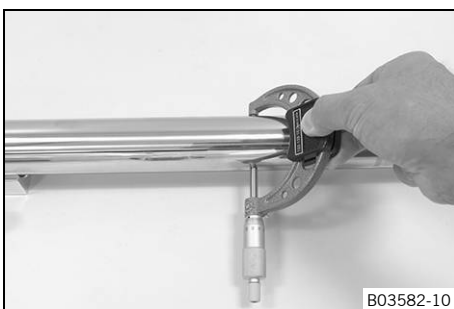

- Measure the outside diameter of the inner tube in several places.

Outside diameter of the inner tube	47.975 ... 48.005 mm (1.88878 ... 1.88996 in)
------------------------------------	--

- » If the measured value is less than the specified value:
 - Change the inner tube.

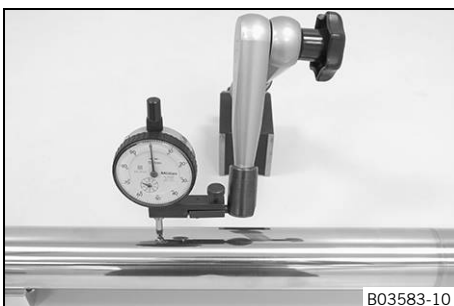

- Measure the run-out of the inner tube.

Inner tub run-out	≤ 0.20 mm (≤ 0.0079 in)
-------------------	-------------------------

- » If the measured value is greater than the specified value:
 - Change the inner tube.

6 FORK, TRIPLE CLAMP



- Check the outer tube for damage.
 - » If damage is found:
 - Change the outer tube.

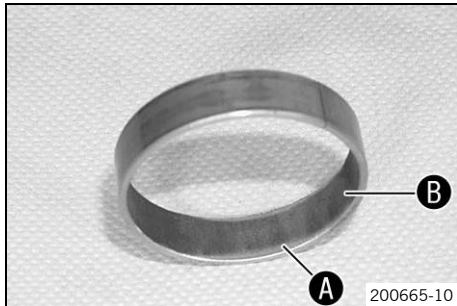

- Check the surface of the sliding bushings.
 - » When the bronze-colored layer **A** becomes visible under the gliding layer **B**:
 - Change the sliding bushings.

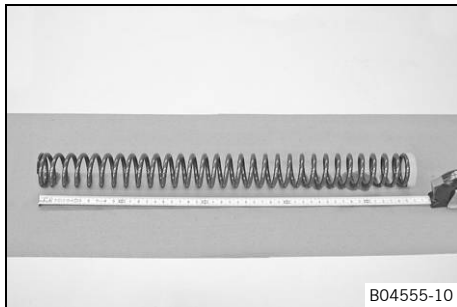

- Check the spring length.

Guideline

Spring length with preload spacer(s)	474 mm (18.66 in)
--------------------------------------	-------------------

- » If the measured value is greater than the specified value:
 - Reduce the thickness of the preload spacers.
- » If the measured value is less than the specified value:
 - Increase the thickness of the preload spacers.

i Info
There may only be one preload spacer installed, or none at all.

6.10.6 Assembling the tap compression

i Info
The procedures are the same on both fork legs.

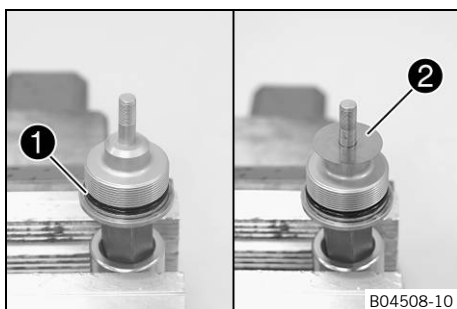

- Mount the tap compression on a suitable hexagon socket and clamp into a vise.
- Mount O-ring **1**.
- Grease O-ring.

Lubricant (T158) (📖 p. 360)

- Mount shim stack **2**.

i Info
Mount the smaller shims below.

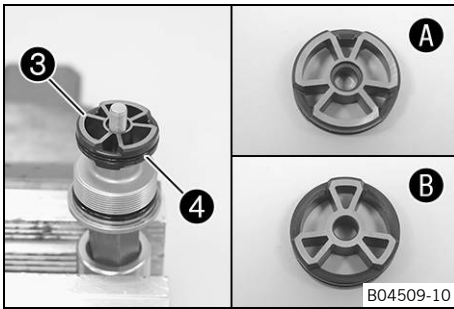

- Mount piston ③.

Guideline

View A	of piston from above
View B	of piston from below

- Mount O-ring ④.
- Grease the piston O-ring.

Fork oil (SAE 4) (48601166S1) (📖 p. 359)

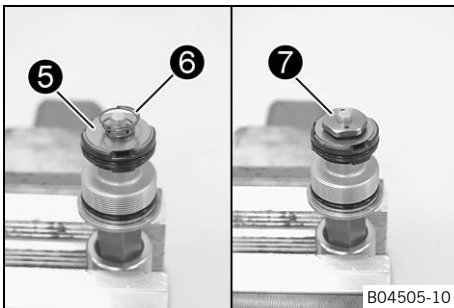

- Mount washer ⑤.
- Mount spring ⑥ with the tighter coil facing downward.
- Mount and tighten nut ⑦.

Guideline

Nut, tap compression	M6x0.5	5 Nm (3.7 lbf ft)
----------------------	--------	-------------------



Info

Washer ⑤ must be free to move against the spring force.

- Extract the tap compression.

6.10.7 Assembling the cartridge

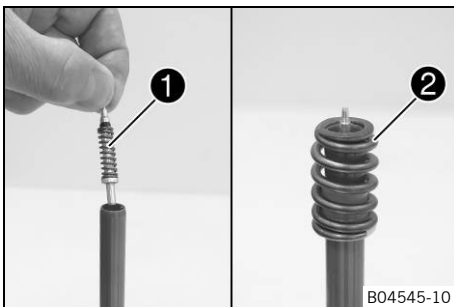

Right cartridge

- Clamp in the piston rod.

Clamping stand (T14016S) (📖 p. 374)

- Mount valve ① of the rebound damping with the spring and O-ring.
- Grease the O-ring.

Lubricant (T158) (📖 p. 360)

- Mount spring ②.
- Mount and grease O-ring ③ in tap rebound ④.

Lubricant (T158) (📖 p. 360)

- Mount and tighten the tap rebound.

Guideline

Tap rebound	M9x1	18 Nm (13.3 lbf ft) Loctite®2701™
-------------	------	---

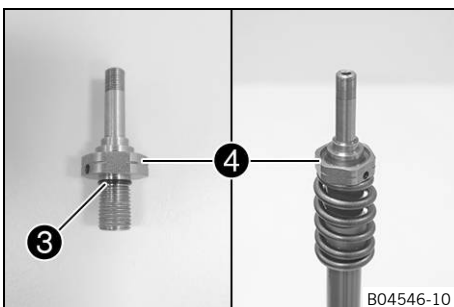

6 FORK, TRIPLE CLAMP

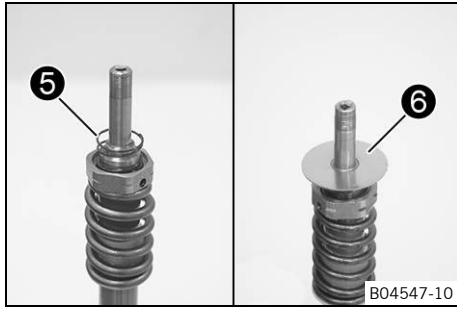

- Position spring 5.
- Mount shim stack 6.

i Info
Mount the smaller shims at the bottom.

- Press the shim stack downward against the spring force.

i Info
The shim stack must be pressed downward over the collar.

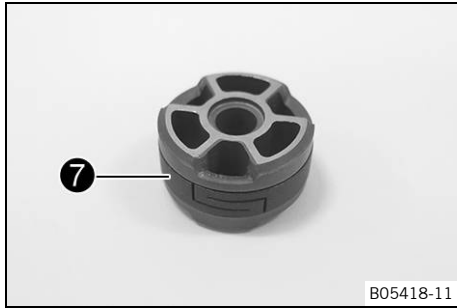

- Mount and lubricate piston ring 7.

Fork oil (SAE 4) (48601166S1) (📖 p. 359)
--



- Mount piston 8 with the piston ring.

Guideline

View A	of piston from above
View B	of piston from below

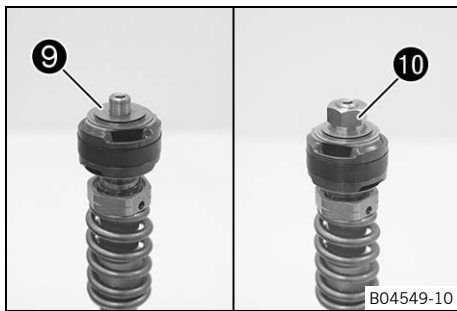

- Mount shim stack 9.

i Info
Align the triangular plate exactly with the piston opening.

- Mount and tighten nut 10 with the collar facing downward.

Guideline

Tap rebound nut	M6x0.5	5 Nm (3.7 lbf ft)
-----------------	--------	-------------------

- ✓ The lower shim stack is free to move against the spring force.

- Lock the nut by center punching it.

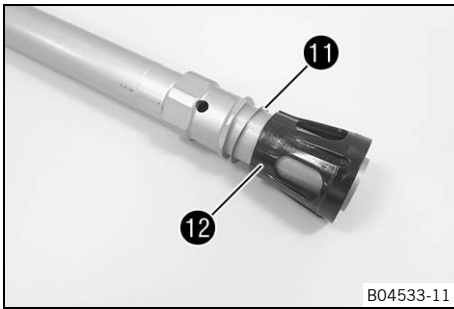

- Mount washer **11** and spring seat **12**.

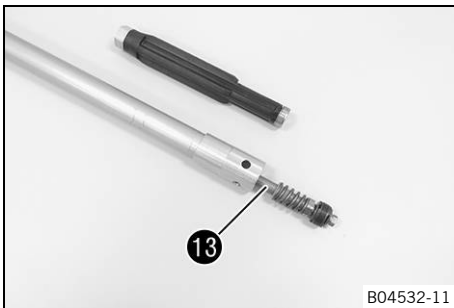

- Slide piston rod **13** into the cartridge.

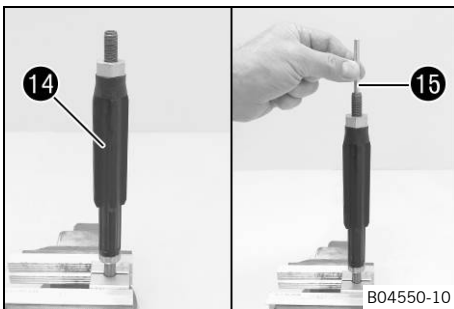

- Mount fluid barrier **14** all the way on.

i Info

The fluid barrier must be tightened all the way. Do not use a tool.

- Mount adjusting tube **15** for the rebound damping in the cartridge.
 - ✓ The adjusting tube protrudes approx. 5 mm (0.197 in) out of the cartridge and can be pressed in against the spring force.
 - ✗ The adjusting tube protrudes more than 7 mm (0.275 in) from the cartridge and cannot be pressed in against the spring force.

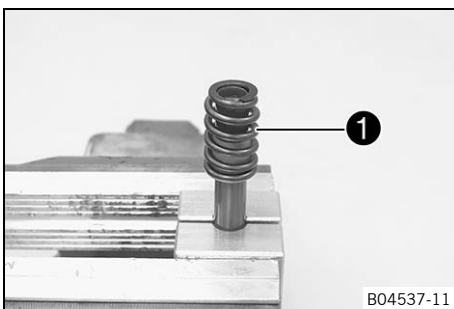

Left cartridge

- Clamp in the piston rod.

Clamping stand (T14016S) (🗨 p. 374)

- Mount spring **1**.

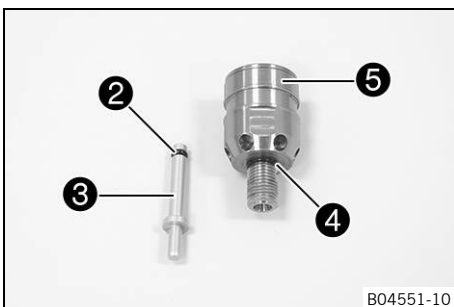

- Mount and lubricate O-ring **2** for setting needle **3**.

Lubricant (T158) (🗨 p. 360)

- Mount and lubricate O-ring **4** for piston **5**.

Lubricant (T158) (🗨 p. 360)

6 FORK, TRIPLE CLAMP

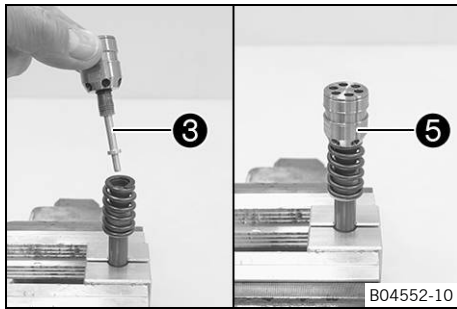

- Insert setting needle **3** in the piston.
- Mount and tighten piston **5**.

Guideline

Rebound piston	M9x1	18 Nm (13.3 lbf ft) Loctite®2701™
----------------	------	---

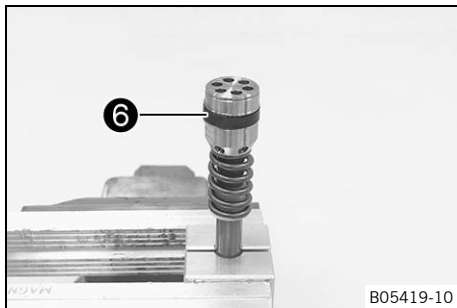

- Mount and lubricate piston ring **6**.

Fork oil (SAE 4) (48601166S1) (📖 p. 359)
--

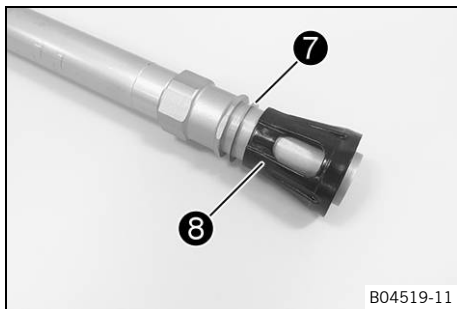

- Mount washer **7** and spring seat **8**.

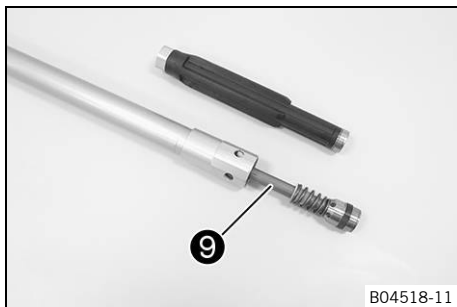

- Slide piston rod **9** into the cartridge.

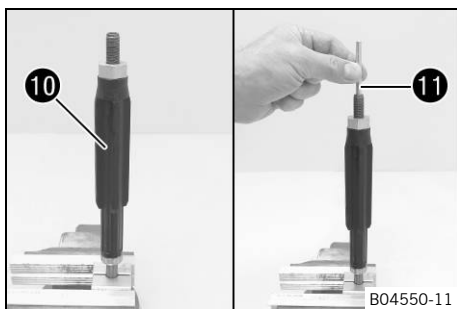

- Mount fluid barrier **10** all the way on.



Info

The fluid barrier must be tightened all the way. Do not use a tool.

- Mount adjusting tube **11** for the rebound damping in the cartridge.
 - ✓ The adjusting tube protrudes approx. 3 mm (0.197 in) out of the cartridge and can be pressed in against the spring force.
 - ✗ The adjusting tube protrudes more than 5 mm (0.275 in) from the cartridge and cannot be pressed in against the spring force.

6.10.8 Assembling the fork legs

i Info

The operations are the same on both fork legs.

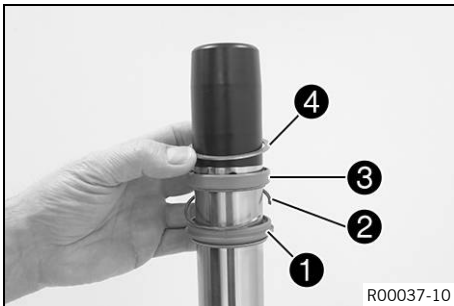

Preparatory work

- Check the fork legs. (📖 p. 27)
- Assemble the cartridge. (📖 p. 29)
- Assemble the tap compression. (📖 p. 28)

Main work

- Clamp the inner tube using the axle clamp.

Guideline

Use soft jaws.

- Mount the special tool.

Protecting sleeve (T1401) (📖 p. 373)

- Grease and push on dust boot **1**.

Lubricant (T14034) (📖 p. 360)

i Info

Always change the dust boot, seal ring, lock ring, and support ring.
Mount the sealing lip with the spring expander facing down.

- Push on lock ring **2**.
- Grease and push on seal ring **3**.

Lubricant (T14034) (📖 p. 360)

i Info

Sealing lip downward, open side upward.

- Push on support ring **4**.
- Remove the special tool.
- Push on lower sliding bushing **5**.
- Mount upper sliding bushing **6**.

i Info

Without using a tool, pull the stack slightly apart by hand.



6 FORK, TRIPLE CLAMP

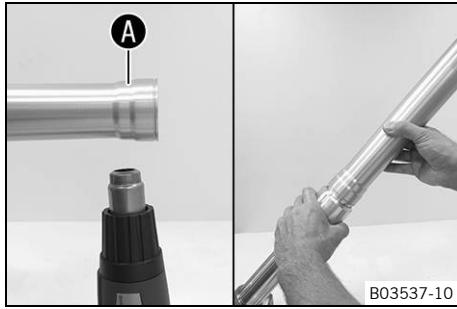

- Warm up the outer tube in area **A** of the lower sliding bushing.

Guideline

50 °C (122 °F)

- Push the outer tube on.
- Hold the lower sliding bushing with the longer side of the special tool.

Mounting tool (T14040S) (📖 p. 375)

- Press the outer tube all the way in.
- Position the support ring.
- Hold the seal ring with the shorter side of the special tool.

Mounting tool (T14040S) (📖 p. 375)

- Press the outer tube all the way in.

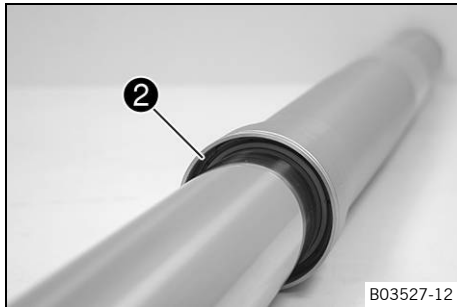
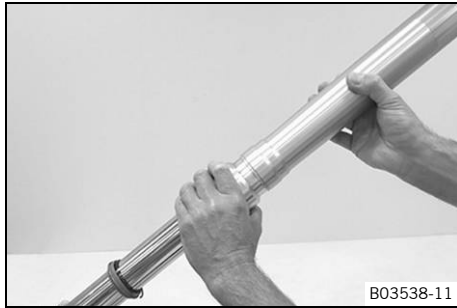

- Mount lock ring **2**.

i Info

The lock ring must engage audibly.

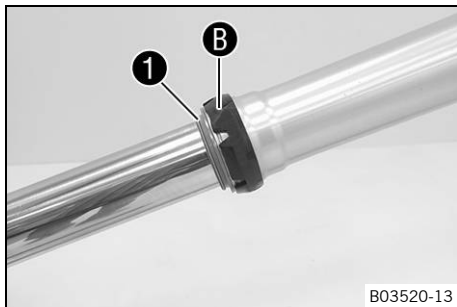

- Mount dust boot **1**.
- Mount fork protector ring **B**.

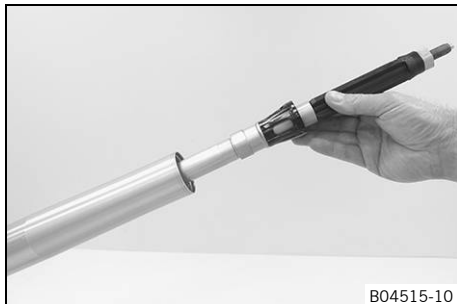

- Slide the cartridge all the way into the inner tube.
 - ✓ The hexagonal part of the cartridge engages in the inner tube guide.

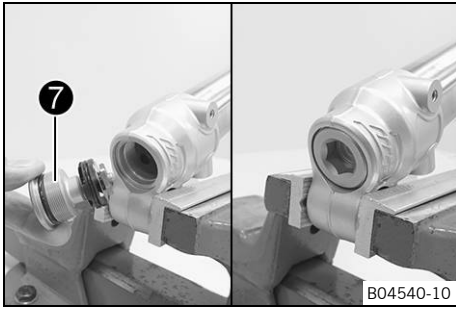

- Mount and tighten tap compression **7**.

Guideline

Compression damp- ing fitting	M29x1	35 Nm (25.8 lbf ft)
----------------------------------	-------	---------------------

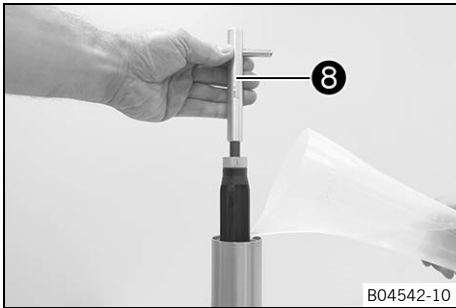

- Mount special tool **8** on the piston rod.

Support tool (T14026S1) (📖 p. 374)

i Info
The special tool must be used to prevent the adjusting tube from being lifted and thus to prevent oil from reaching the piston rod.

- Clamp the fork vertically.
- Fill with fork oil.

Fork oil per fork leg	642 ± 10 ml (21.71 ± 0.34 fl. oz.)	Fork oil (SAE 4) (48601166S1) (📖 p. 359)
-----------------------	--	--

i Info
Pull out the piston rod and push back in a number of times to bleed the cartridge.

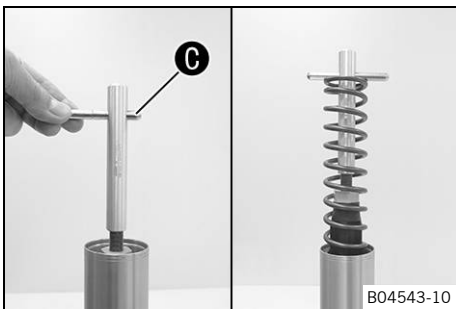

- Remove pin **C** of the special tool.

Support tool (T14026S1) (📖 p. 374)

- Pull out the piston rod. Mount the spring. Mount the pin again.

Spring rate	
Weight of rider: 65 ... 75 kg (143 ... 165 lb.)	4.0 N/mm (22.8 lb/in)
Weight of rider: 75 ... 85 kg (165 ... 187 lb.)	4.2 N/mm (24 lb/in)
Weight of rider: 85 ... 95 kg (187 ... 209 lb.)	4.4 N/mm (25.1 lb/in)

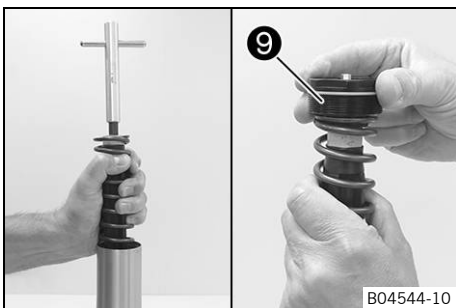

- Pull the spring downward.
- Remove the special tool.

Support tool (T14026S1) (📖 p. 374)

- Mount screw cap **9**.

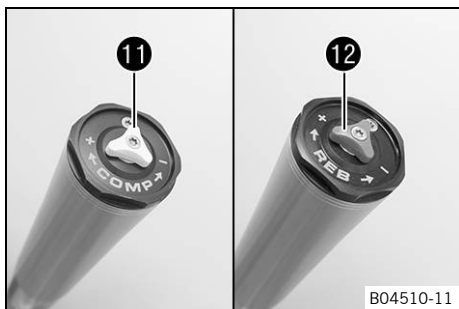

i Info

When assembling, ensure that the screw caps are mounted correctly.
 Rebound damping side – right fork leg, screw cap with marking **REB**, red adjuster.
 Compression damping side – left fork leg, screw cap with marking **COMP**, white adjuster.

- Pull the spring downward.
- Mount the open end wrench on the hexagonal part.
- Hold the open end wrench. Tighten the screw cover.

Guideline

Screw cap on piston rod	M12x1	25 Nm (18.4 lbf ft)
-------------------------	-------	---------------------

Ring wrench (T14017) (📖 p. 374)

- Push the outer tube upward.
- Clamp the outer tube in the area of the lower triple clamp.

Clamping stand (T1403S) (📖 p. 374)

- Grease the O-ring of the screw cover.

Lubricant (T158) (📖 p. 360)

- Mount and tighten screw cap **9**.

Guideline

Screw cap on outer tube	M51x1.5	40 Nm (29.5 lbf ft)
-------------------------	---------	---------------------

Ring wrench (T14017) (📖 p. 374)

- Mount the adjuster.
- Mount and tighten screw **10**.

Guideline

Screw, adjuster	M4x0.5	2.5 Nm (1.84 lbf ft)
-----------------	--------	----------------------

Alternative 1

- Turn compression adjuster **11** and rebound adjuster **12** clockwise all the way.
- Turn counterclockwise by the number of clicks corresponding to the fork type.

Guideline

Rebound damping	
Comfort	18 clicks
Standard	15 clicks
Sport	12 clicks
Compression damping	
Comfort	18 clicks
Standard	15 clicks
Sport	12 clicks

Alternative 2



Warning

Danger of accident Modifications to the suspension setting may seriously alter the handling characteristic.

Extreme modifications to the suspension setting may cause a serious deterioration in the handling characteristic and overload components.

- Only make adjustments within the recommended range.
- Ride slowly to start with after making adjustments to get the feel of the new handling characteristic.

- Set the adjusters to the positions determined upon removal.



6.10.9 Lubricating the steering head bearing

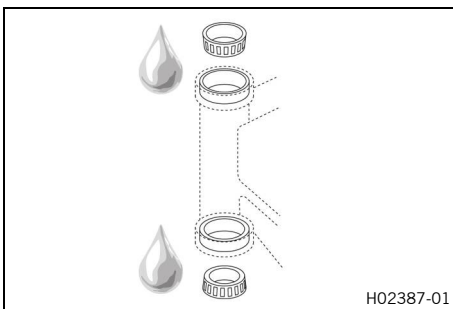

- Remove the lower triple clamp. (🔧 p. 37)
- Install the lower triple clamp. (🔧 p. 38)



6.10.10 Removing the lower triple clamp

Preparatory work

- Raise the motorcycle with a lift stand. (🔧 p. 12)
- Remove the front wheel. (🔧 p. 141)
- Remove the headlight mask with the headlight. (🔧 p. 135)
- Remove the fork legs. (🔧 p. 17)
- Remove front fender. (🔧 p. 134)
- Remove the handlebar cushion.

6 FORK, TRIPLE CLAMP

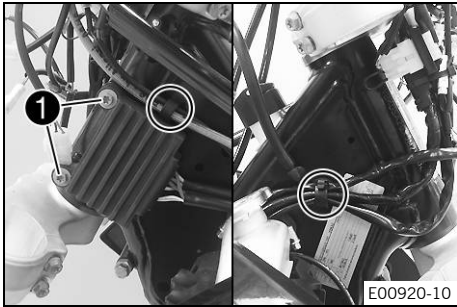

Main work

- Remove screws **1** and hang the voltage regulator to the side.
- Open the cable holder in front of the left and right radiator and detach the wiring harness.

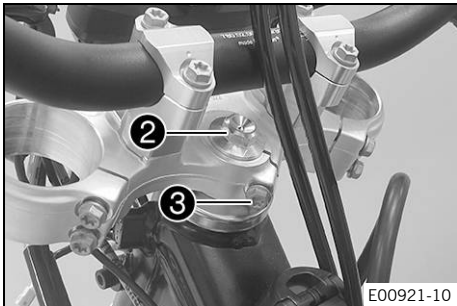

- Remove screw **2**.
- Loosen screw **3**. Take off the upper triple clamp with the handlebar and hang them to the side.



Info

Cover the components to protect them against damage. Do not kink the cables and lines.

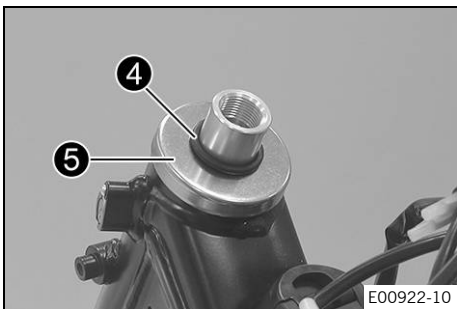

- Remove O-ring **4**. Remove protective ring **5**.
- Take off the lower triple clamp with the steering stem.
- Remove the upper steering head bearing.

6.10.11 Installing the lower triple clamp

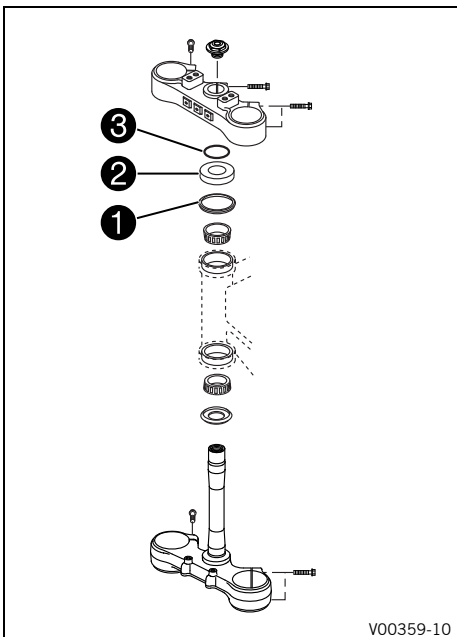

Main work

- Clean the bearing and sealing elements, check for damage, and grease.
- High viscosity grease (📖 p. 360)
- Insert the lower triple clamp with the steering stem. Mount the upper steering head bearing.
 - Check whether upper steering head seal **1** is correctly positioned.
 - Mount protective ring **2** and O-ring **3**.

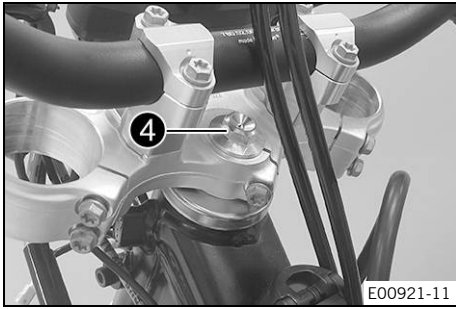

- Position the upper triple clamp with the handlebar.
- Position the clutch line and wiring harness.
- Mount screw **4** but do not tighten yet.

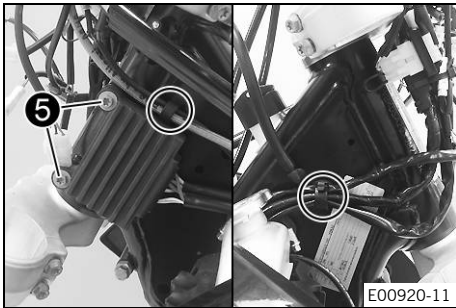

- Position the voltage regulator, and mount and tighten screws **5**.

Guideline

Remaining screws, chassis	M6	10 Nm (7.4 lbf ft)
---------------------------	----	--------------------

- Secure wiring harnesses with cable holders.

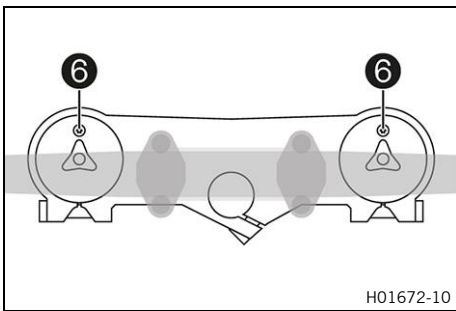

- Position the fork legs.
- ✓ Bleeder screws **6** are positioned toward the front.

i Info

The rebound damping is located in right fork leg **REB** (red adjusting screw). The compression damping is located in left fork leg **COMP** (white adjusting screw). Grooves are milled into the side of the upper end of the fork legs. The second milled groove (from the top) must be flush with the top edge of the upper triple clamp.

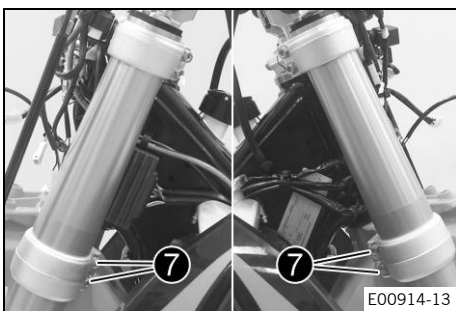

- Tighten screws **7**.

Guideline

Screw, bottom triple clamp	M8	15 Nm (11.1 lbf ft)
----------------------------	----	---------------------

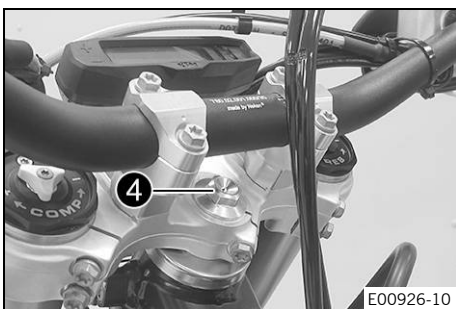

- Tighten screw **4**.

Guideline

Screw, top steering head	M20x1.5	12 Nm (8.9 lbf ft)
--------------------------	---------	--------------------

6 FORK, TRIPLE CLAMP

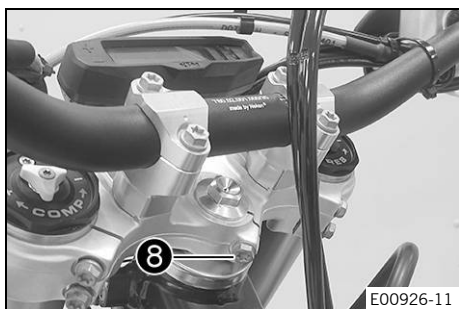

- Tighten screw **8**.

Guideline

Screw, top steering stem	M8	20 Nm (14.8 lbf ft)
--------------------------	----	---------------------

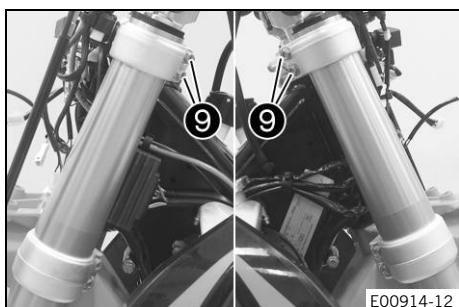

- Tighten screws **9**.

Guideline

Screw, top triple clamp	M8	20 Nm (14.8 lbf ft)
-------------------------	----	---------------------

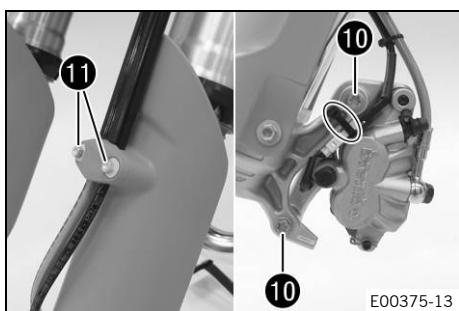

- Position the brake caliper, and mount and tighten screws **10**.

Guideline

Screw, front brake caliper	M8	25 Nm (18.4 lbf ft) Loctite®243™
----------------------------	----	--

- Mount the cable tie(s).
- Position the brake line, wiring harness, and clamp. Mount and tighten screws **11**.

Finishing work

- Mount the handlebar cushion.
- Install front fender. (📖 p. 134)
- Install the front wheel. (📖 p. 142)
- Install the headlight mask with the headlight. (📖 p. 135)
- Check that the wiring harness, throttle cables, and brake and clutch lines can move freely and are routed correctly.
- Check the play of the steering head bearing. (📖 p. 42)
- Remove the motorcycle from the lift stand. (📖 p. 12)
- Check the headlight setting. (📖 p. 183)

6.10.12 Changing the steering head bearing

Preparatory work

- Raise the motorcycle with a lift stand. (📖 p. 12)
- Remove the front wheel. (📖 p. 141)
- Remove the headlight mask with the headlight. (📖 p. 135)
- Remove the fork legs. (📖 p. 17)
- Remove front fender. (📖 p. 134)
- Remove the handlebar cushion.
- Remove the lower triple clamp. (📖 p. 37)

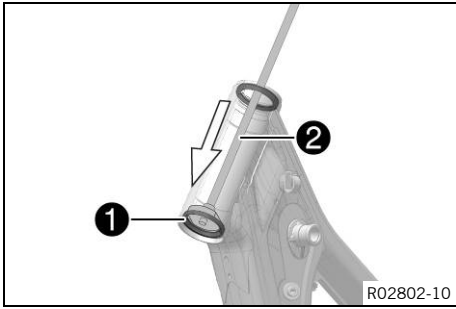

Main work

- Remove lower bearing ring **1** with special tool **2**.

Tool bracket (58429089000) (📖 p. 368)

Pressing tool (58429092000) (📖 p. 368)
--

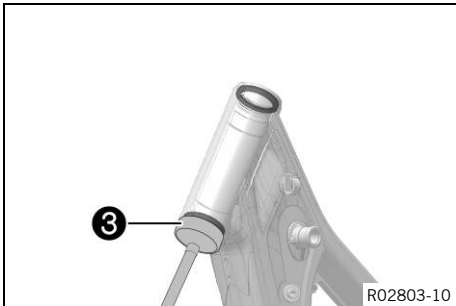

- Press the new bearing ring up to the stop with special tool **3**.

Tool bracket (58429089000) (📖 p. 368)

Pressing tool (58429091000) (📖 p. 368)
--

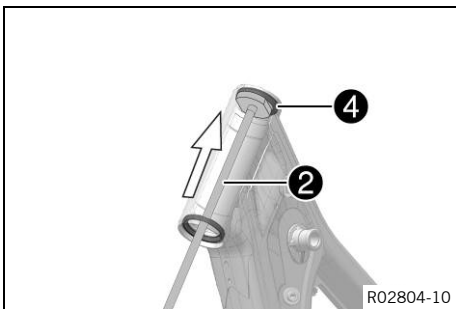

- Remove upper bearing ring **4** with special tool **2**.

Tool bracket (58429089000) (📖 p. 368)

Pressing tool (58429092000) (📖 p. 368)
--

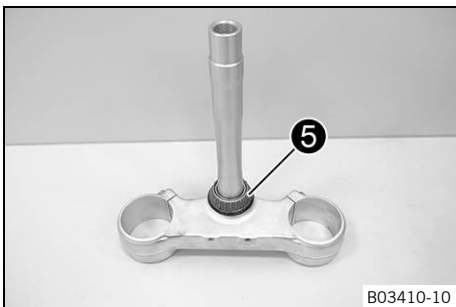

- Remove lower steering head bearing **5**.
- Remove the seal ring.
- Grease and mount the new seal ring.
- Press on the new bearing with a suitable tube as far as it will go.



Info

Only press the bearing in via the inner ring.

Finishing work

- Install the lower triple clamp. (📖 p. 38)
- Mount the handlebar cushion.
- Install front fender. (📖 p. 134)
- Install the front wheel. (📖 p. 142)
- Install the headlight mask with the headlight. (📖 p. 135)
- Check that the wiring harness, throttle cables, and brake and clutch lines can move freely and are routed correctly.
- Check the play of the steering head bearing. (📖 p. 42)
- Remove the motorcycle from the lift stand. (📖 p. 12)
- Check the headlight setting. (📖 p. 183)

6.10.13 Checking the play of the steering head bearing



Warning

Danger of accidents Incorrect steering head bearing play impairs the handling characteristic and damages components.

- Correct incorrect steering head bearing play immediately.



Info

If the vehicle is operated for a lengthy period with play in the steering head bearing, the bearings and the bearing seats in the frame can become damaged over time.

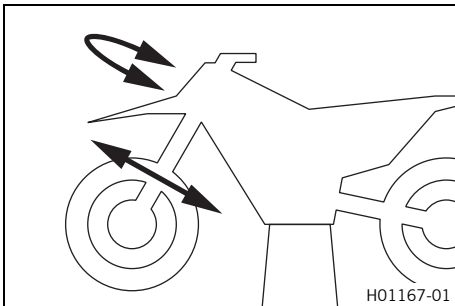

Preparatory work

- Raise the motorcycle with a lift stand. (📖 p. 12)

Main work

- Move the handlebar to the straight-ahead position. Move the fork legs to and fro in the direction of travel.

Play should not be detectable on the steering head bearing.

- » If there is detectable play:
 - Adjust the steering head bearing play. (📖 p. 42)

- Move the handlebar to and fro over the entire steering range.

It must be possible to move the handlebar easily over the entire steering range. There should be no detectable detent positions.

- » If detent positions are detected:
 - Adjust the steering head bearing play. (📖 p. 42)
 - Check the steering head bearing and change if necessary.

Finishing work

- Remove the motorcycle from the lift stand. (📖 p. 12)

6.10.14 Adjusting the steering head bearing play

Preparatory work

- Raise the motorcycle with a lift stand. (📖 p. 12)

Main work

- Loosen screws ① and ②.
- Loosen and retighten screw ③.

Guideline

Screw, top steering head	M20x1.5	12 Nm (8.9 lbf ft)
--------------------------	---------	--------------------

- Using a plastic hammer, tap lightly on the upper triple clamp to avoid stresses.

- Tighten screws ①.

Guideline

Screw, top triple clamp	M8	20 Nm (14.8 lbf ft)
-------------------------	----	---------------------

- Tighten screw ②.

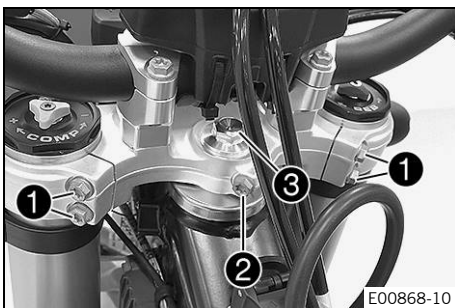

Guideline

Screw, top steering stem	M8	20 Nm (14.8 lbf ft)
--------------------------	----	---------------------

Finishing work

- Check the play of the steering head bearing. (📖 p. 42)
- Remove the motorcycle from the lift stand. (📖 p. 12)



6.11 All Six Days models

6.11.1 Servicing the fork

Condition

The fork legs have been removed.

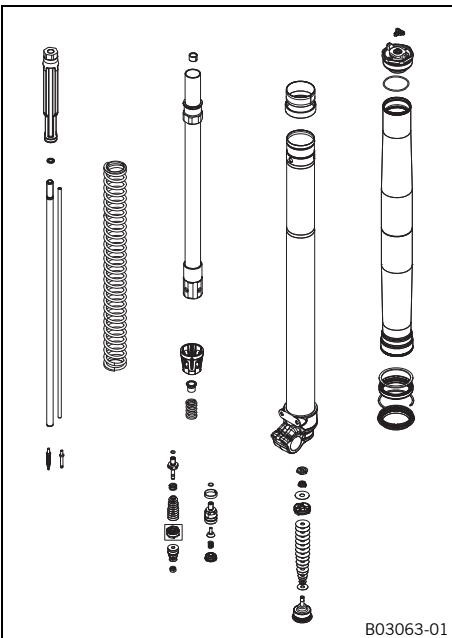

- Disassemble the fork legs. (📖 p. 43)
- Disassemble the cartridge. (📖 p. 46)
- Check the fork legs. (📖 p. 50)
- Assemble the cartridge. (📖 p. 52)
- Assemble the fork legs. (📖 p. 56)



6.11.2 Disassembling the fork legs



Info

The operations are the same on both fork legs.

Condition

The fork legs have been removed.

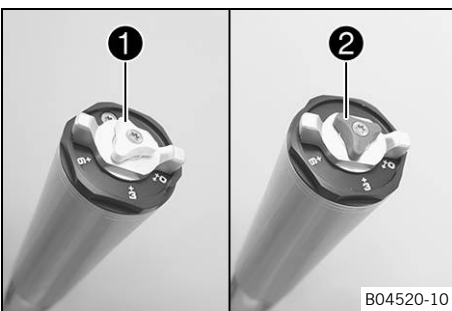

- Note down the current state of compression damping **1 COMP** (white adjuster on the left fork leg).
- Note down the current state of rebound damping **2 REB** (red adjuster on the right fork leg).
- Open the adjusters of the rebound and compression damping completely.

6 FORK, TRIPLE CLAMP

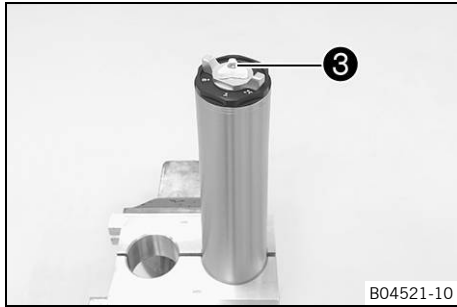

- Clamp the fork leg in the area of the lower triple clamp.

Clamping stand (T1403S) (📖 p. 374)

- Remove screw **3**. Remove adjuster.



- Loosen the screw cover **4**.

Ring wrench (T14017) (📖 p. 374)



Info

The screw cover cannot be removed yet.

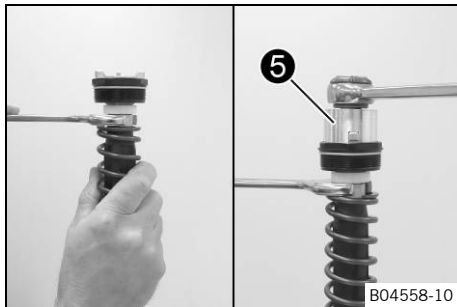

- Extract the fork leg and push the outer tube downward.
- Pull the spring downward and push the open end wrench onto the hexagonal part.
- Hold the hexagonal part and loosen Preload Adjuster with special tool **5**, but do not take it off yet.

Special socket (T14087) (📖 p. 375)



- Pull the spring downward. Remove the open end wrench.
- Remove the screw cap.

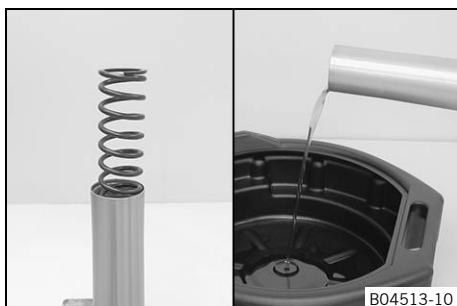

- Remove the spring.
- Drain the fork oil.



Info

Pull out and push in the piston rod a few times to pump the cartridge empty.

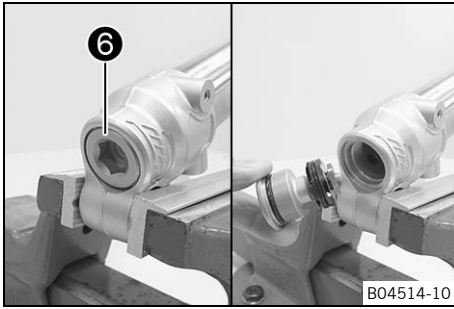

- Clamp the fork leg with the axle clamp.

Guideline

Use soft jaws.

- Unscrew and remove compression holder 6.



Info

Place a container underneath as oil will run out in most cases.

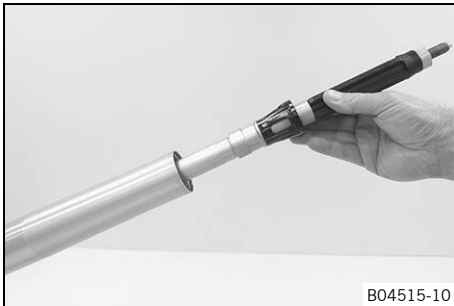

- Remove the cartridge.

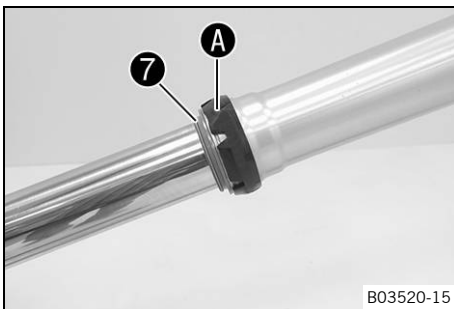

- Remove dust boot 7.
- Remove fork protector ring A.



Info

The fork protector ring does not necessarily need to be removed for repair work.

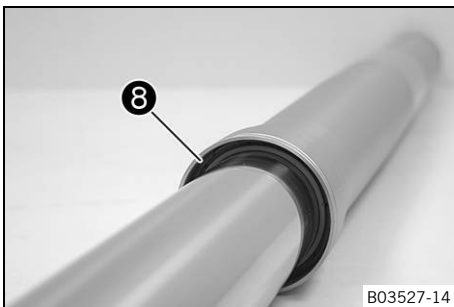

- Remove lock ring 8.



Info

The lock ring has a beveled end where a screwdriver can be applied.

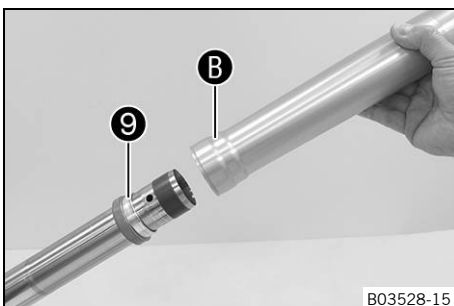

- Warm up the outer tube in area B of the lower sliding bushing.

Guideline

50 °C (122 °F)

- Pull the outer tube from the inner tube with a jerk.



Info

Lower sliding bushing 9 must be pulled from its bearing seat.

6 FORK, TRIPLE CLAMP

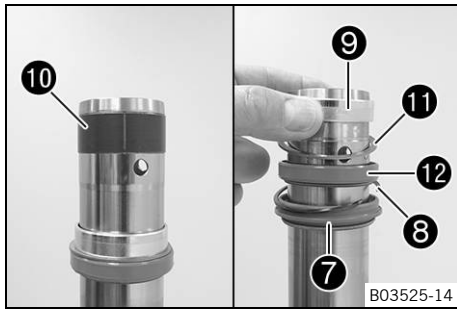

- Remove upper sliding bushing 10.



Info

Without using a tool, pull the stack slightly apart by hand.

- Take off lower sliding bushing 9.
- Take off support ring 11.
- Take off seal ring 12.
- Take off lock ring 8.
- Take off dust boot 7.
- Unclamp the fork leg.

6.11.3 Disassembling the cartridge

Preparatory work

- Disassemble the fork legs. (📖 p. 43)

Right cartridge

- Clamp the piston rod with the special tool.

Clamping stand (T14016S) (📖 p. 374)

- Remove adjusting tube 1.
- Remove fluid barrier 2 from the piston rod.

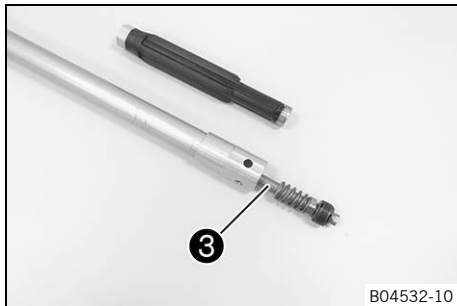
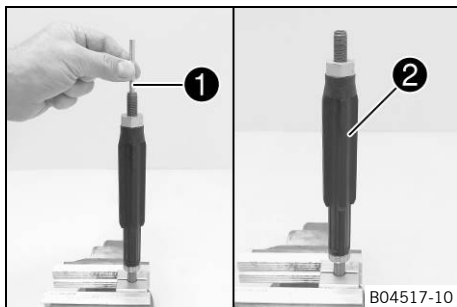

- Take piston rod 3 out of the cartridge.

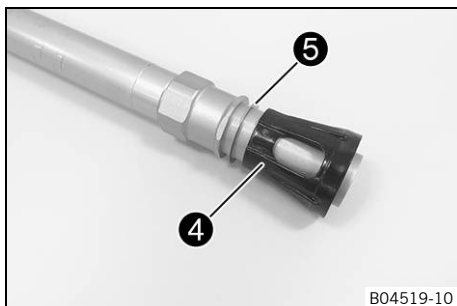

- Take spring seat 4 and washer 5 off of the cartridge.

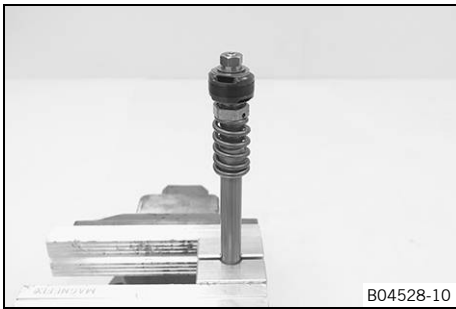

- Degrease the piston rod.
- Clamp the piston rod with the special tool.

Clamping stand (T14016S) (📖 p. 374)

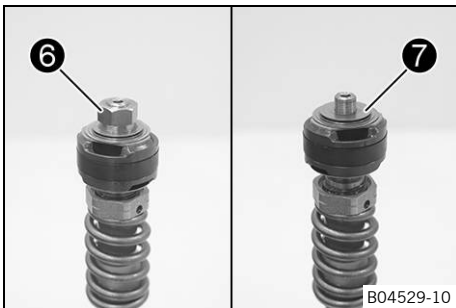

- Remove nut 6.
- Completely remove shim stack 7.

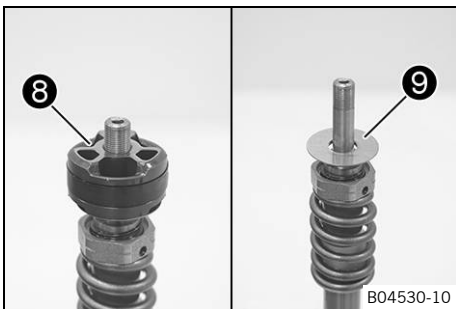

- Remove piston 8.
- Completely remove shim stack 9.

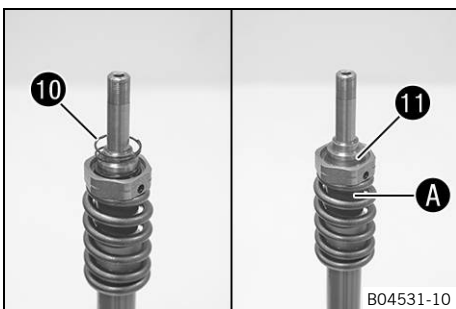

- Remove spring 10.
- Warm up the piston rod in area A.

Guideline

50 °C (122 °F)

- Remove tap rebound 11.

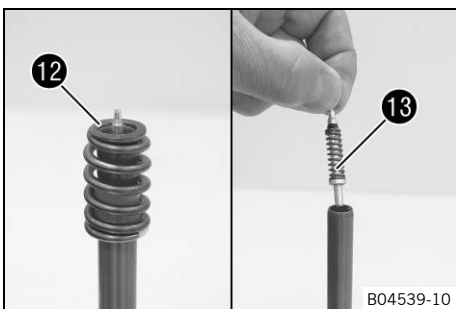

- Remove spring 12.
- Remove valve 13 of the rebound damping with the spring.
- Unclamp the piston rod.

6 FORK, TRIPLE CLAMP

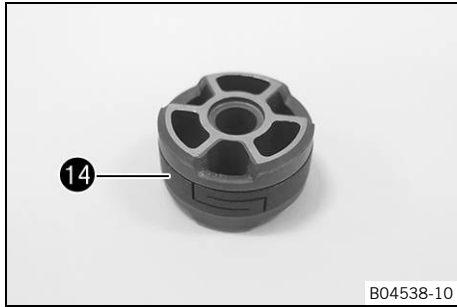

- Remove piston ring 14.

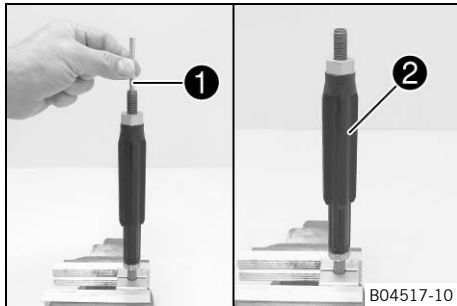

Left cartridge

- Clamp the piston rod with the special tool.
Clamping stand (T14016S) (📖 p. 374)
- Remove adjusting tube 1.
- Remove fluid barrier 2 from the piston rod.

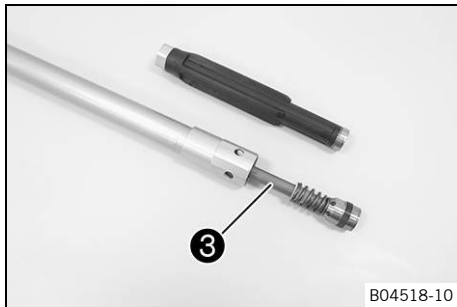

- Take piston rod 3 out of the cartridge.

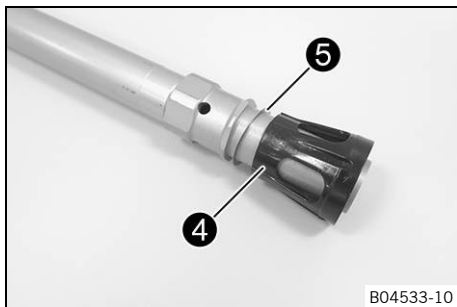

- Take spring seat 4 and washer 5 off of the cartridge.

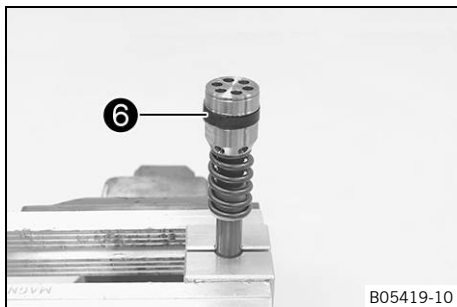

- Degrease the piston rod.
- Clamp the piston rod with the special tool.
Clamping stand (T14016S) (📖 p. 374)
- Remove piston ring 6.

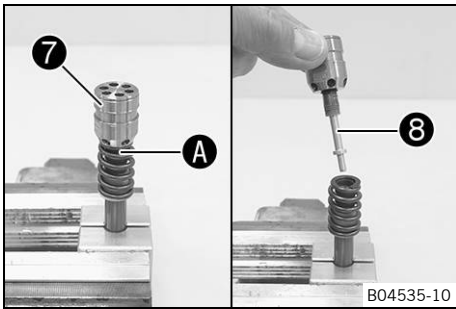

- Warm up the piston rod in area **A**.

Guideline

50 °C (122 °F)

- Remove piston **7** with setting needle **8**.

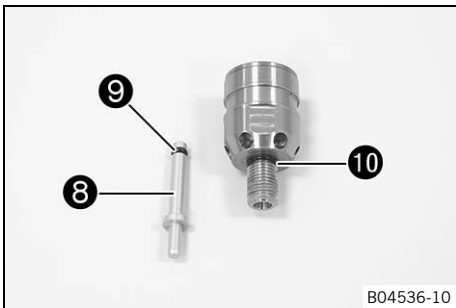

- Pull setting needle **8** out of the piston.
- Remove O-rings **9** and **10**.

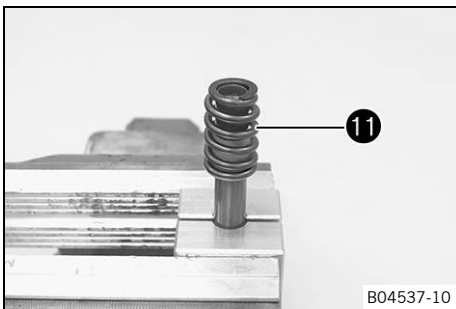

- Remove spring **11**.
- Unclamp the piston rod.

6.11.4 Disassembling the tap compression

i Info

The procedures are the same on both fork legs.

Preparatory work

- Disassemble the fork legs. (📖 p. 43)

Main work

- Mount the tap compression on a suitable hexagon socket and clamp into a vise.
- Remove nut **1**.
- Remove spring **2**.
- Remove washer **3**.

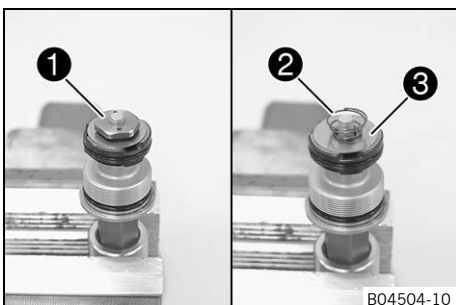

6 FORK, TRIPLE CLAMP

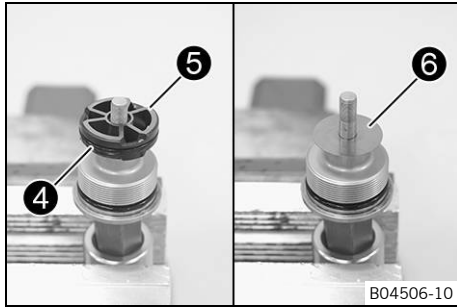

- Remove O-ring ④.
- Remove piston ⑤.
- Remove shim stack ⑥.

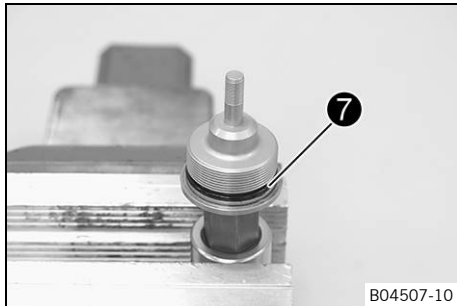

- Remove O-ring ⑦ from the tap compression.
- Extract the tap compression.

6.11.5 Checking the fork legs

Condition

The fork legs have been disassembled.



- Check the inner tube and the axle clamp for damage.
 - » If damage is found:
 - Change the inner tube.

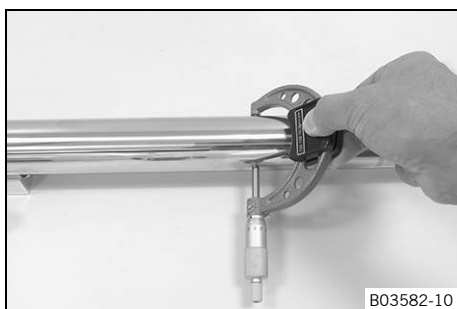

- Measure the outside diameter of the inner tube in several places.

Outside diameter of the inner tube	47.975 ... 48.005 mm (1.88878 ... 1.88996 in)
------------------------------------	--

- » If the measured value is less than the specified value:
 - Change the inner tube.

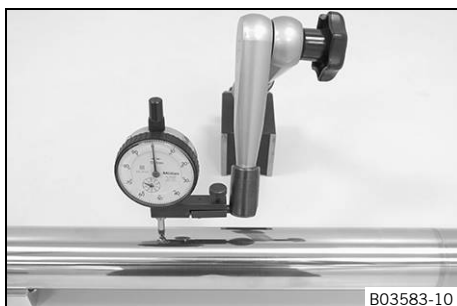

- Measure the run-out of the inner tube.

Inner tub run-out	≤ 0.20 mm (≤ 0.0079 in)
-------------------	-------------------------

- » If the measured value is greater than the specified value:
 - Change the inner tube.



B03584-10

- Check the outer tube for damage.
 - » If damage is found:
 - Change the outer tube.

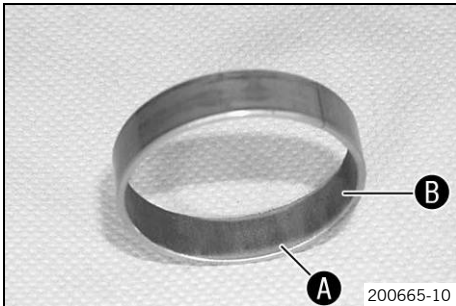

200665-10

- Check the surface of the sliding bushings.
 - » When bronze-colored layer **A** becomes visible under gliding layer **B**:
 - Change the guiding bushes.

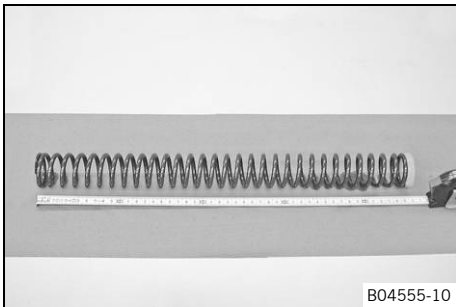

B04555-10

- Check the spring length.

Guideline

Spring length with preload spacer(s)	474 mm (18.66 in)
--------------------------------------	-------------------

- » If the measured value is greater than the specified value:
 - Reduce the thickness of the preload spacers.
- » If the measured value is less than the specified value:
 - Increase the thickness of the preload spacers.



Info

There may only be one preload spacer installed, or none at all.

6.11.6 Assembling the tap compression



Info

The procedures are the same on both fork legs.

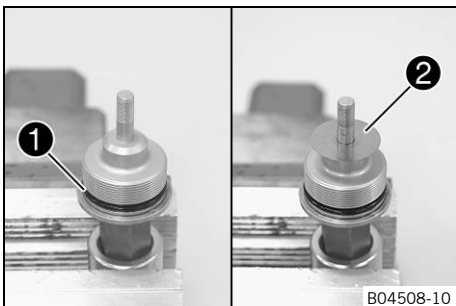

B04508-10

- Mount the tap compression on a suitable hexagon socket and clamp into a vise.
- Mount O-ring **1**.
- Grease O-ring.

Lubricant (T158) (🗨️ p. 360)

- Mount shim stack **2**.



Info

Mount the smaller shims below.

6 FORK, TRIPLE CLAMP

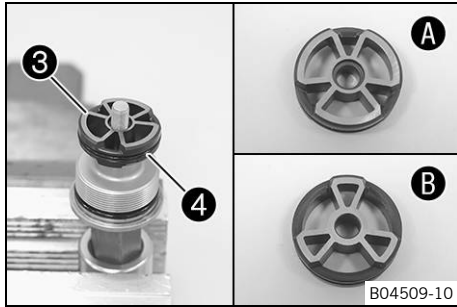

- Mount piston **3**.

Guideline

View A	of piston from above
View B	of piston from below

- Mount O-ring **4**.
- Grease the piston O-ring.

Fork oil (SAE 4) (48601166S1) (📖 p. 359)

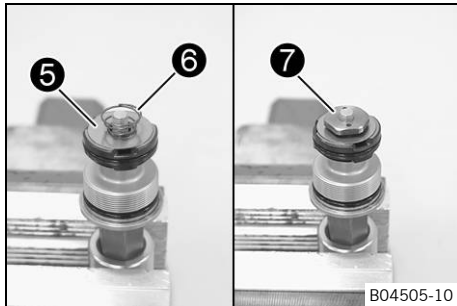

- Mount washer **5**.
- Mount spring **6** with the tighter coil facing downward.
- Mount and tighten nut **7**.

Guideline

Nut, tap compression	M6x0.5	5 Nm (3.7 lbf ft)
----------------------	--------	-------------------

i Info

Washer **5** must be free to move against the spring force.

- Extract the tap compression.

6.11.7 Assembling the cartridge

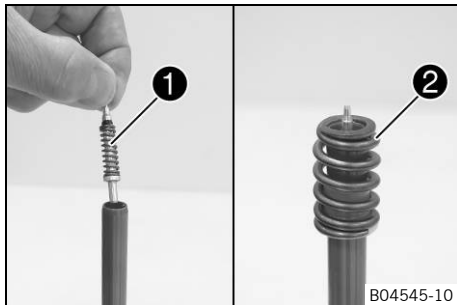

Right cartridge

- Clamp in the piston rod.

Clamping stand (T14016S) (📖 p. 374)

- Mount valve **1** of the rebound damping with the spring and O-ring.
- Grease the O-ring.

Lubricant (T158) (📖 p. 360)

- Mount spring **2**.

- Mount and grease O-ring **3** in tap rebound **4**.

Lubricant (T158) (📖 p. 360)

- Mount and tighten the tap rebound.

Guideline

Tap rebound	M9x1	18 Nm (13.3 lbf ft) Loctite®2701™
-------------	------	---

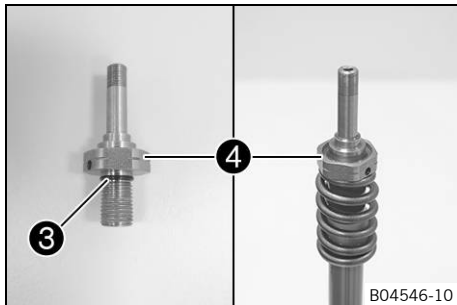

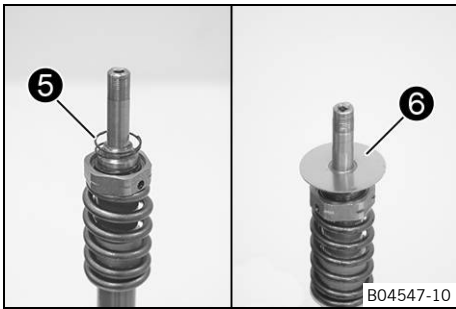

- Position spring 5.
- Mount shim stack 6.

i Info
Mount the smaller shims at the bottom.

- Press the shim stack downward against the spring force.

i Info
The shim stack must be pressed downward over the collar.

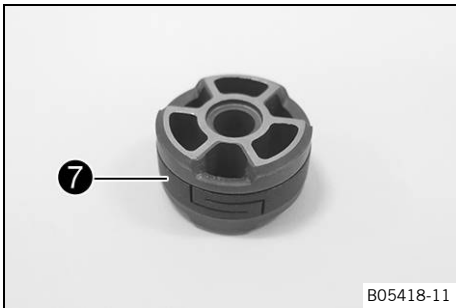

- Mount and lubricate piston ring 7.

Fork oil (SAE 4) (48601166S1) (📖 p. 359)
--



- Mount piston 8 with the piston ring.

Guideline

View A	of piston from above
View B	of piston from below

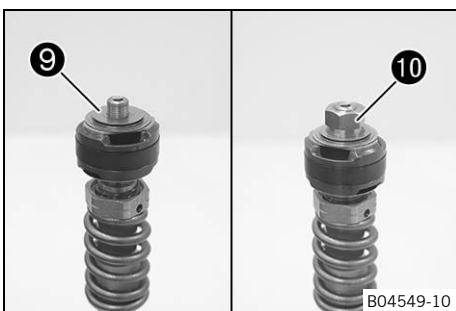

- Mount shim stack 9.

i Info
Align the triangular plate exactly with the piston opening.

- Mount and tighten nut 10 with the collar facing downward.

Guideline

Tap rebound nut	M6x0.5	5 Nm (3.7 lbf ft)
-----------------	--------	-------------------

✓ The lower shim stack is free to move against the spring force.

- Lock the nut by center punching it.

6 FORK, TRIPLE CLAMP

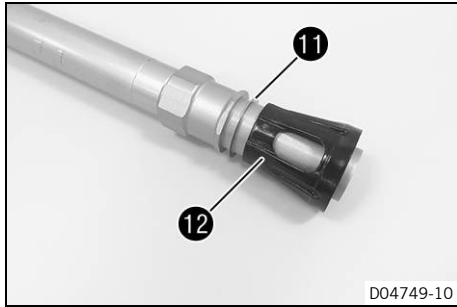

- Mount washer **11** and spring seat **12**.

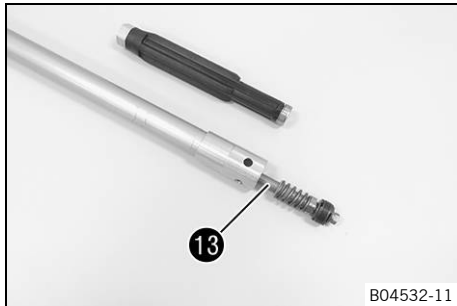

- Slide piston rod **13** into the cartridge.

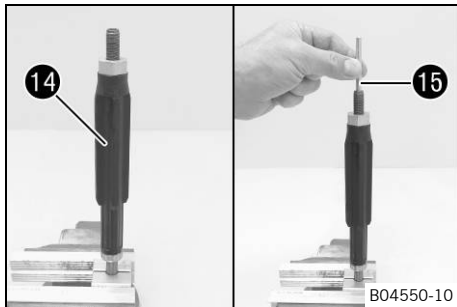

- Mount fluid barrier **14** all the way on.



Info

The fluid barrier must be tightened all the way. Do not use a tool.

- Mount adjusting tube **15** for the rebound damping in the cartridge.
 - ✓ The adjusting tube protrudes approx. 5 mm (0.197 in) out of the cartridge and can be pressed in against the spring force.
 - ✗ The adjusting tube protrudes more than 7 mm (0.275 in) from the cartridge and cannot be pressed in against the spring force.

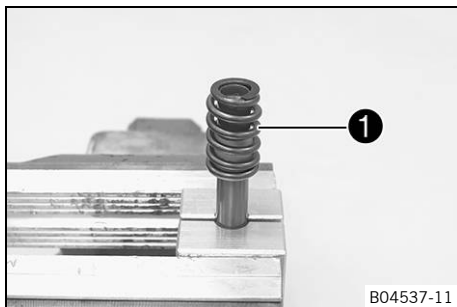

Left cartridge

- Clamp in the piston rod.

Clamping stand (T14016S) (📖 p. 374)

- Mount spring **1**.

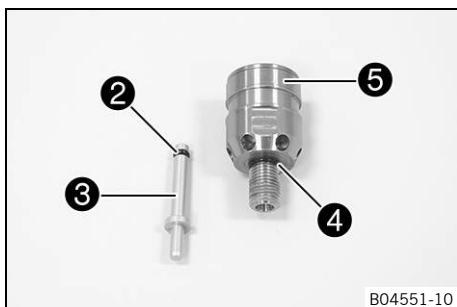

- Mount and lubricate O-ring **2** for setting needle **3**.

Lubricant (T158) (📖 p. 360)

- Mount and lubricate O-ring **4** for piston **5**.

Lubricant (T158) (📖 p. 360)

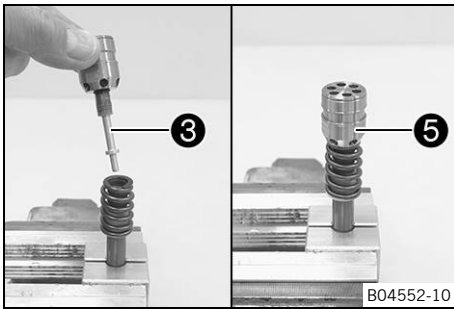

- Insert setting needle **3** in the piston.
- Mount and tighten piston **5**.

Guideline

Compression piston	M9x1	18 Nm (13.3 lbf ft) Loctite®2701™
--------------------	------	---

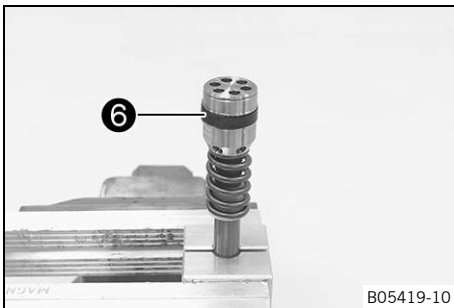

- Mount and lubricate piston ring **6**.

Fork oil (SAE 4) (48601166S1) (📖 p. 359)
--

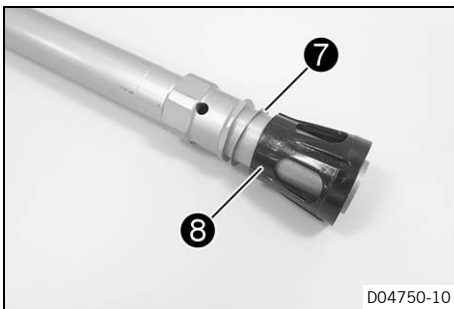

- Mount washer **7** and spring seat **8**.

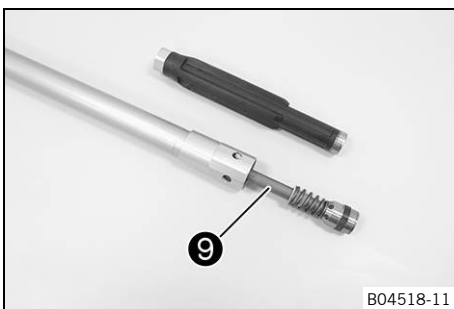

- Slide piston rod **9** into the cartridge.

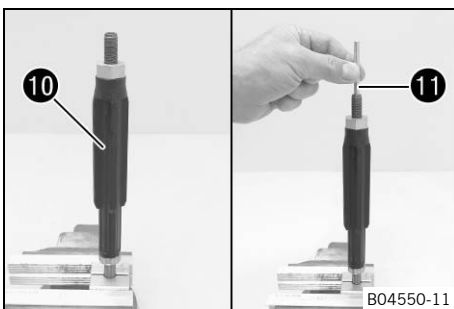

- Mount fluid barrier **10** all the way on.



Info

The fluid barrier must be tightened all the way. Do not use a tool.

- Mount adjusting tube **11** for the rebound damping in the cartridge.
 - ✓ The adjusting tube protrudes approx. 3 mm (0.197 in) out of the cartridge and can be pressed in against the spring force.
 - ✗ The adjusting tube protrudes more than 5 mm (0.275 in) from the cartridge and cannot be pressed in against the spring force.



6.11.8 Assembling the fork legs

i Info

The operations are the same on both fork legs.

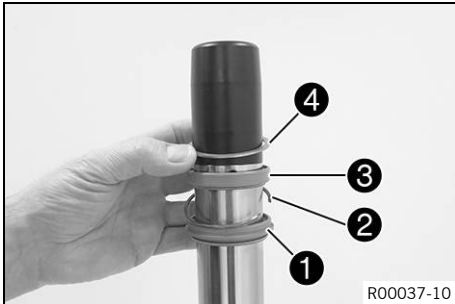

Preparatory work

- Check the fork legs. (📖 p. 50)
- Assemble the tap compression. (📖 p. 51)
- Assemble the cartridge. (📖 p. 52)

Main work

- Clamp the inner tube using the axle clamp.

Guideline

Use soft jaws.

- Mount the special tool.

Protecting sleeve (T1401) (📖 p. 373)

- Grease and push on dust boot **1**.

Lubricant (T14034) (📖 p. 360)

i Info

Always change the dust boot, seal ring, lock ring, and support ring.
Mount the sealing lip with the spring expander facing down.

- Push on lock ring **2**.

- Grease and push on seal ring **3**.

Lubricant (T14034) (📖 p. 360)

i Info

Sealing lip downward, open side upward.

- Push on support ring **4**.

- Remove the special tool.

- Push on lower sliding bushing **5**.

- Mount upper sliding bushing **6**.

i Info

Without using a tool, pull the stack slightly apart by hand.



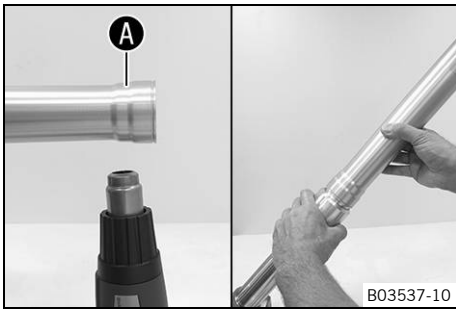

- Warm up the outer tube in area **A** of the lower sliding bushing.

Guideline

50 °C (122 °F)

- Push the outer tube on.
- Hold the lower sliding bushing with the longer side of the special tool.

Mounting tool (T14040S) (📖 p. 375)

- Press the outer tube all the way in.

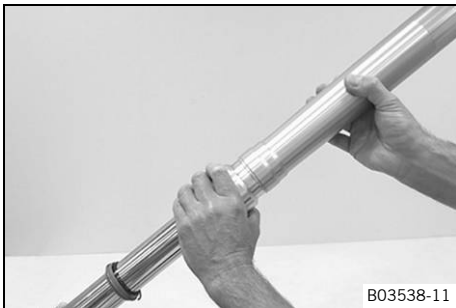

- Position the support ring.
- Hold the seal ring with the shorter side of the special tool.

Mounting tool (T14040S) (📖 p. 375)

- Press the outer tube all the way in.

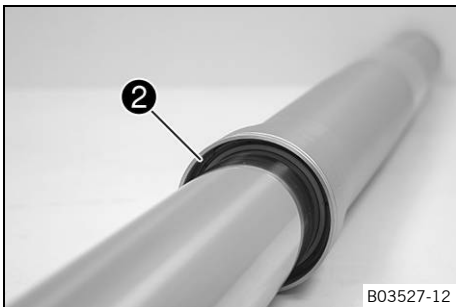

- Mount lock ring **2**.



Info

The lock ring must engage audibly.

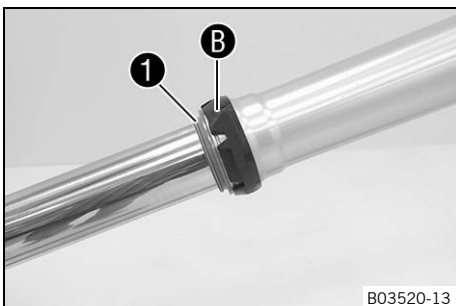

- Mount dust boot **1**.
- Mount fork protector ring **B**.

6 FORK, TRIPLE CLAMP

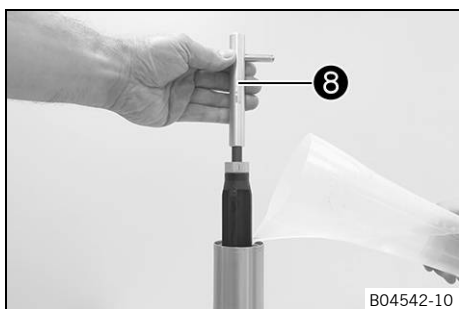
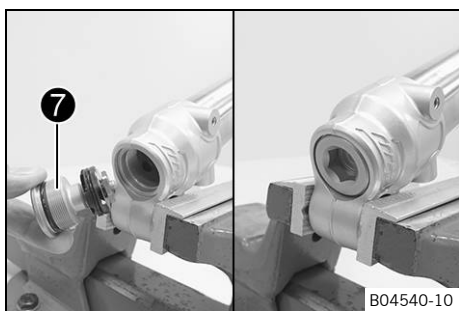

- Slide the cartridge all the way into the inner tube.
- ✓ The hexagonal part of the cartridge engages in the inner tube guide.

i Info

When assembling, ensure that the cartridges are not mixed up. The cartridges with the holes are installed on the left. The cartridge without the hole is installed on the right.

- Mount and tighten tap compression **7**.

Guideline

Compression damping fitting	M29x1	35 Nm (25.8 lbf ft)
-----------------------------	-------	---------------------

- Mount special tool **8** on the piston rod.

Support tool (T14026S1) (📖 p. 374)

i Info

The special tool must be used to prevent the adjusting tube from being lifted and thus to prevent oil from reaching the piston rod.

- Clamp the fork vertically.
- Fill with fork oil.

Fork oil per fork leg	635 ± 10 ml (21.47 ± 0.34 fl. oz.)	Fork oil (SAE 4) (48601166S1) (📖 p. 359)
-----------------------	--	--

i Info

Pull out the piston rod and push back in a number of times to bleed the cartridge.

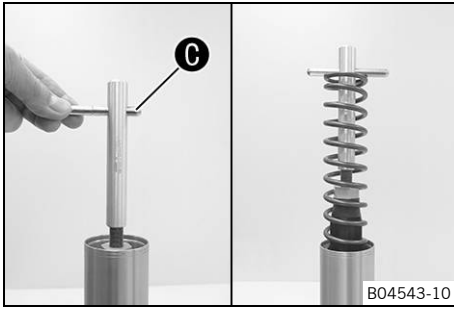

- Remove pin 6 of the special tool.

Support tool (T14026S1) (p. 374)

- Pull out the piston rod. Mount the spring. Mount the pin again.
Guideline

Spring rate	
Weight of rider: 65 ... 75 kg (143 ... 165 lb.)	4.0 N/mm (22.8 lb/in)
Weight of rider: 75 ... 85 kg (165 ... 187 lb.)	4.2 N/mm (24 lb/in)
Weight of rider: 85 ... 95 kg (187 ... 209 lb.)	4.4 N/mm (25.1 lb/in)

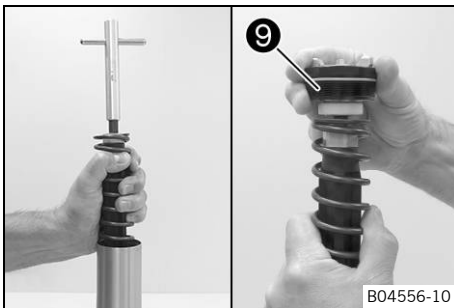

- Pull the spring downward.
- Remove the special tool.

Support tool (T14026S1) (p. 374)

- Mount screw cap 9.

i Info
When assembling, ensure that the screw caps are mounted correctly.
Rebound damping side – right fork leg, screw cap with marking **REB**, red adjuster.
Compression damping side – left fork leg, screw cap with marking **COMP**, white adjuster.

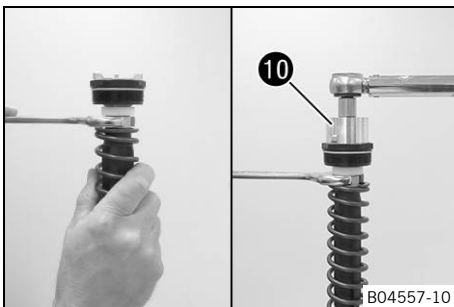

- Pull the spring downward.
- Mount the open end wrench on the hexagonal part.
- Hold the open end wrench. Tighten Preload Adjuster with special tool 10.

Guideline

Preload Adjuster on the piston rod	M12x1	25 Nm (18.4 lbf ft)
--	-------	---------------------

Special socket (T14087) (p. 375)



- Push the outer tube upward.
- Clamp the outer tube in the area of the lower triple clamp.

Clamping stand (T1403S) (p. 374)

- Grease the O-ring of the screw cover.

Lubricant (T158) (p. 360)

- Mount and tighten screw cap 9.

Guideline

Screw cap on outer tube	M51x1.5	40 Nm (29.5 lbf ft)
----------------------------	---------	---------------------

Ring wrench (T14017) (p. 374)

6 FORK, TRIPLE CLAMP



- Mount the adjuster.
- Mount and tighten screw 11.

Guideline

Screw, adjuster	M4x0.5	2.5 Nm (1.84 lbf ft)
-----------------	--------	-------------------------

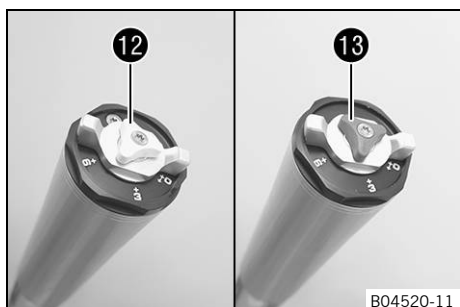

Alternative 1

- Turn compression adjuster 12 and rebound adjuster 13 clockwise all the way.
- Turn counterclockwise by the number of clicks corresponding to the fork type.

Guideline

Rebound damping	
Comfort	18 clicks
Standard	15 clicks
Sport	12 clicks
Compression damping	
Comfort	18 clicks
Standard	15 clicks
Sport	12 clicks

- Set the spring preload according to the fork type.

Guideline

Spring preload - Preload Adjuster	
Comfort	+0
Standard	+0
Sport	+3

Alternative 2



Warning

Danger of accident Modifications to the suspension setting may seriously alter the handling characteristic.

Extreme modifications to the suspension setting may cause a serious deterioration in the handling characteristic and overload components.

- Only make adjustments within the recommended range.
- Ride slowly to start with after making adjustments to get the feel of the new handling characteristic.

- Set the adjusters to the positions determined upon removal.

6.11.9 Lubricating the steering head bearing

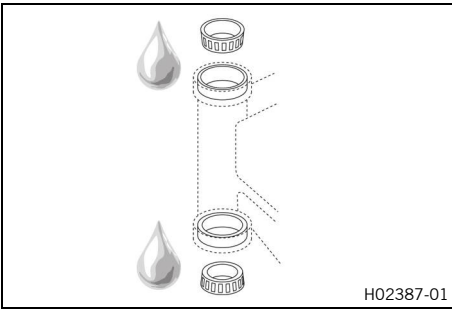

- Remove the lower triple clamp. (📖 p. 61)
- Install the lower triple clamp. (📖 p. 62)

6.11.10 Removing the lower triple clamp

Preparatory work

- Raise the motorcycle with a lift stand. (📖 p. 12)
- Remove the front wheel. (📖 p. 141)
- Remove the headlight mask with the headlight. (📖 p. 135)
- Remove the fork legs. (📖 p. 17)
- Remove front fender. (📖 p. 134)
- Remove the handlebar cushion.

Main work

- Remove screws ❶ and hang the voltage regulator to the side.
- Open the cable holder in front of the left and right radiator and detach the wiring harness.

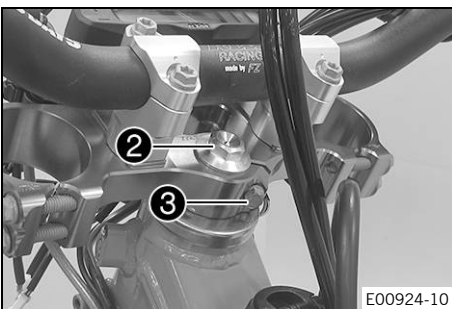
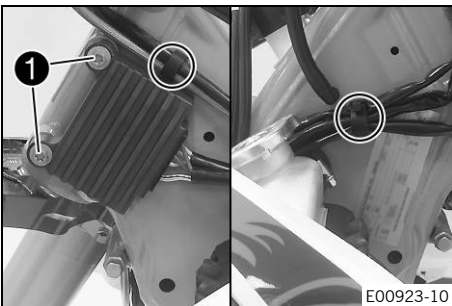

- Remove screw ❷.
- Remove screw ❸. Take off the upper triple clamp with the handlebar and set it aside.



Info

Cover the components to protect them against damage. Do not kink the cables and lines.

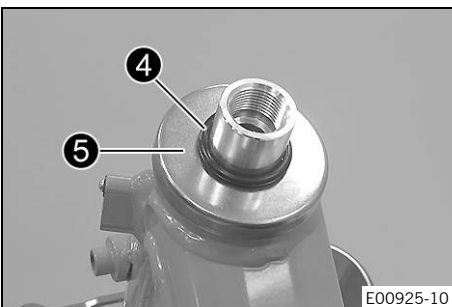

- Remove O-ring ❹. Remove protective ring ❺.
- Take off the lower triple clamp with the steering stem.
- Remove the upper steering head bearing.

6.11.11 Installing the lower triple clamp

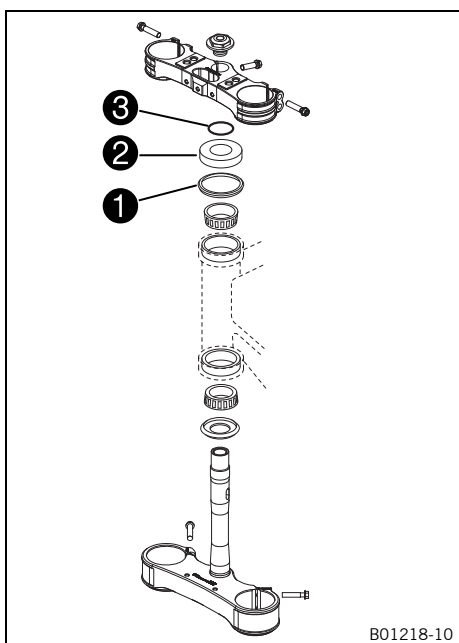

Main work

- Clean the bearing and sealing elements, check for damage, and grease.
- High viscosity grease (📖 p. 360)
- Insert the lower triple clamp with the steering stem. Mount the upper steering head bearing.
 - Check whether upper steering head seal **1** is correctly positioned.
 - Mount protective ring **2** and O-ring **3**.

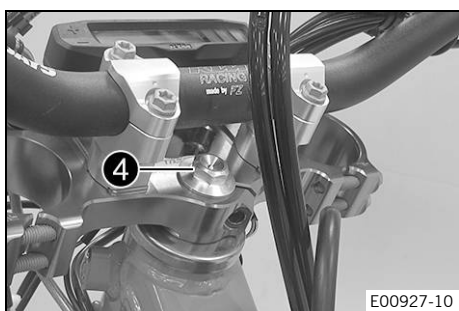

- Position the upper triple clamp with the handlebar.
- Mount screw **4** but do not tighten yet.
- Position the clutch line and wiring harness.

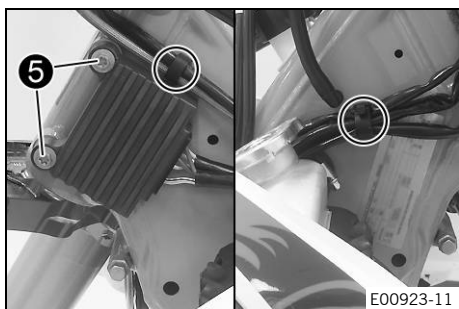

- Position the voltage regulator, and mount and tighten screws **5**.

Guideline

Remaining screws, chassis	M6	10 Nm (7.4 lbf ft)
---------------------------	----	--------------------

- Secure wiring harnesses with cable holders.

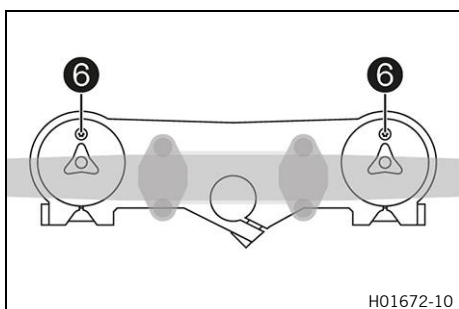

- Position the fork legs.
- ✓ Bleeder screws **6** are positioned toward the front.

Info

The rebound damping is located in right fork leg **REB** (red adjusting screw). The compression damping is located in left fork leg **COMP** (white adjusting screw). Grooves are milled into the side of the upper end of the fork legs. The second milled groove (from the top) must be flush with the top edge of the upper triple clamp.

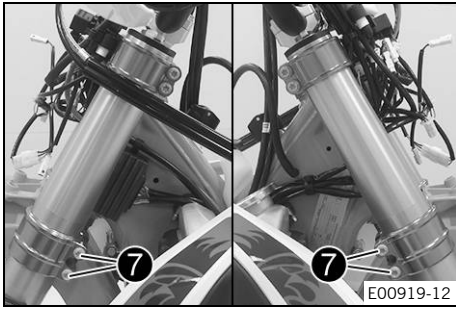

- Tighten screws 7.

Guideline

Screw, bottom triple clamp	M8	15 Nm (11.1 lbf ft)
----------------------------	----	---------------------

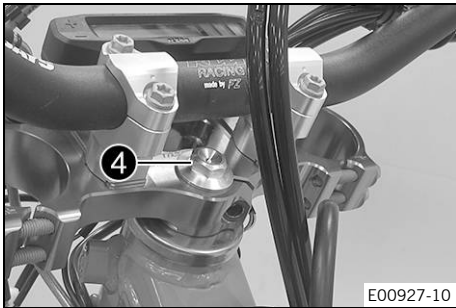

- Tighten screw 4.

Guideline

Screw, top steering head	M20x1.5	12 Nm (8.9 lbf ft)
--------------------------	---------	--------------------

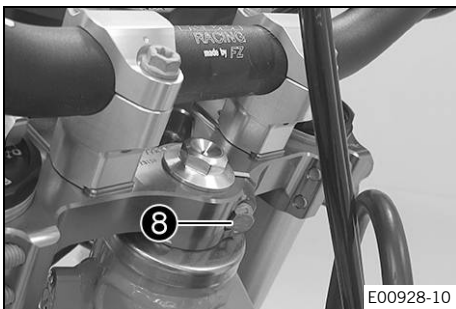

- Mount and tighten screw 8.

Guideline

Screw, top steering stem	M8	17 Nm (12.5 lbf ft) Loctite®243™
--------------------------	----	--

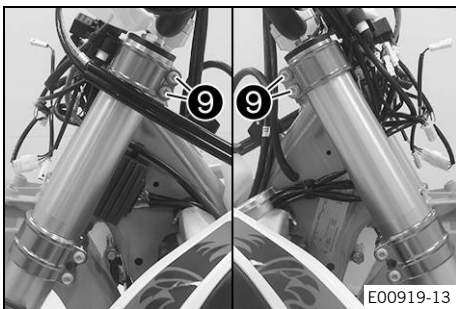

- Tighten screws 9.

Guideline

Screw, top triple clamp	M8	17 Nm (12.5 lbf ft)
-------------------------	----	---------------------

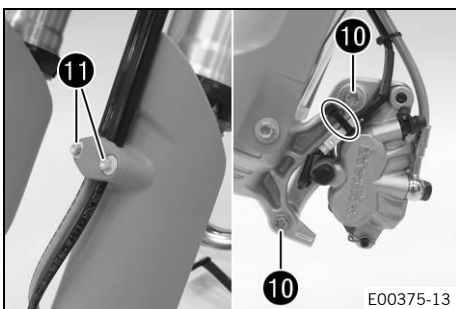

- Position the brake caliper, and mount and tighten screws 10.

Guideline

Screw, front brake caliper	M8	25 Nm (18.4 lbf ft) Loctite®243™
----------------------------	----	--

- Mount the cable tie(s).
- Position the brake line, wiring harness, and clamp. Mount and tighten screws 11.

Finishing work

- Mount the handlebar cushion.
- Install front fender. (📖 p. 134)
- Install the front wheel. (📖 p. 142)
- Install the headlight mask with the headlight. (📖 p. 135)

- Check that the wiring harness, throttle cables, and brake and clutch lines can move freely and are routed correctly.
- Check the play of the steering head bearing. (📖 p. 65)
- Remove the motorcycle from the lift stand. (📖 p. 12)
- Check the headlight setting. (📖 p. 183)

6.11.12 Changing the steering head bearing

Preparatory work

- Raise the motorcycle with a lift stand. (📖 p. 12)
- Remove the front wheel. (📖 p. 141)
- Remove the headlight mask with the headlight. (📖 p. 135)
- Remove the fork legs. (📖 p. 17)
- Remove front fender. (📖 p. 134)
- Remove the handlebar cushion.
- Remove the lower triple clamp. (📖 p. 61)

Main work

- Remove lower bearing ring ❶ with special tool ❷.

Tool bracket (58429089000) (📖 p. 368)

Pressing tool (58429092000) (📖 p. 368)
--

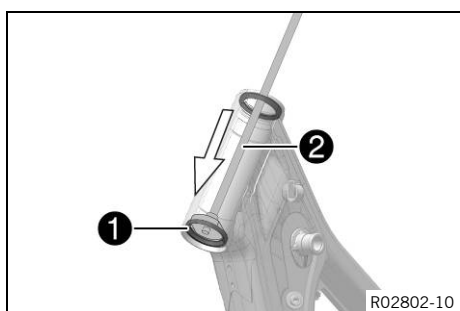

- Press the new bearing ring up to the stop with special tool ❸.

Tool bracket (58429089000) (📖 p. 368)

Pressing tool (58429091000) (📖 p. 368)
--

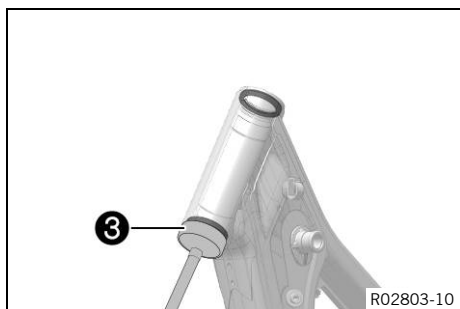

- Remove upper bearing ring ❹ with special tool ❷.

Tool bracket (58429089000) (📖 p. 368)

Pressing tool (58429092000) (📖 p. 368)
--

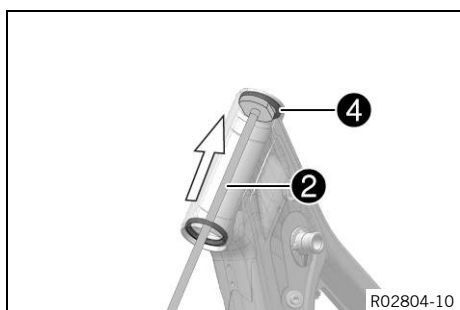

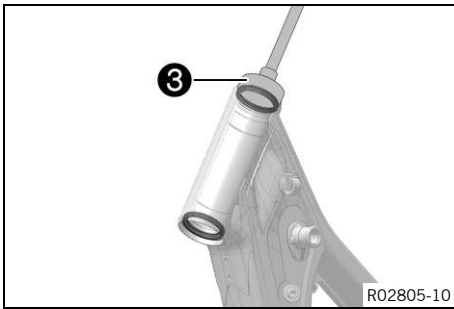

- Press the new bearing ring up to the stop with special tool ③.

Tool bracket (58429089000) (📖 p. 368)

Pressing tool (58429091000) (📖 p. 368)
--

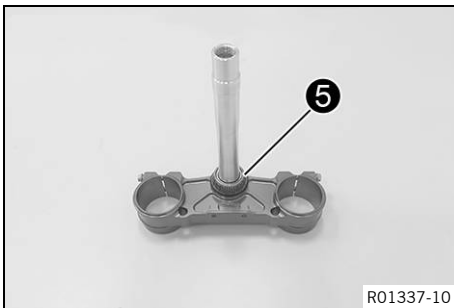

- Remove lower steering head bearing ⑤.
- Remove the seal ring.
- Grease and mount the new seal ring.
- Press on the new bearing with a suitable tube as far as it will go.

i Info

Only press the bearing in via the inner ring.

Finishing work

- Install the lower triple clamp. (📖 p. 62)
- Mount the handlebar cushion.
- Install front fender. (📖 p. 134)
- Install the front wheel. (📖 p. 142)
- Install the headlight mask with the headlight. (📖 p. 135)
- Check that the wiring harness, throttle cables, and brake and clutch lines can move freely and are routed correctly.
- Check the play of the steering head bearing. (📖 p. 65)
- Remove the motorcycle from the lift stand. (📖 p. 12)
- Check the headlight setting. (📖 p. 183)

6.11.13 Checking the play of the steering head bearing



Warning

Danger of accidents Incorrect steering head bearing play impairs the handling characteristic and damages components.

- Correct incorrect steering head bearing play immediately.



Info

If the vehicle is operated for a lengthy period with play in the steering head bearing, the bearings and the bearing seats in the frame can become damaged over time.

Preparatory work

- Raise the motorcycle with a lift stand. (📖 p. 12)

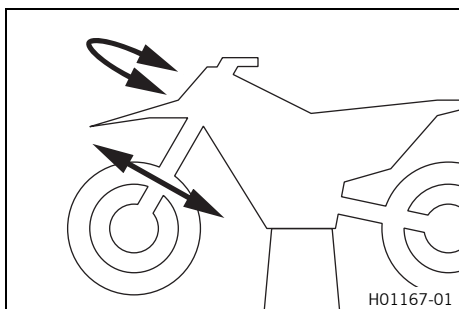

Main work

- Move the handlebar to the straight-ahead position. Move the fork legs to and fro in the direction of travel.

Play should not be detectable on the steering head bearing.

- » If there is detectable play:
 - Adjust the steering head bearing play. (🔧 p. 66)

- Move the handlebar to and fro over the entire steering range.

It must be possible to move the handlebar easily over the entire steering range. There should be no detectable detent positions.

- » If detent positions are detected:
 - Adjust the steering head bearing play. (🔧 p. 66)
 - Check the steering head bearing and change if necessary.

Finishing work

- Remove the motorcycle from the lift stand. (🔧 p. 12)

6.11.14 Adjusting the steering head bearing play

Preparatory work

- Raise the motorcycle with a lift stand. (🔧 p. 12)

Main work

- Loosen screws ❶. Remove screw ❷.
- Loosen and retighten screw ❸.

Guideline

Screw, top steering head	M20x1.5	12 Nm (8.9 lbf ft)
--------------------------	---------	--------------------

- Using a plastic hammer, tap lightly on the upper triple clamp to avoid stresses.

- Tighten screws ❶.

Guideline

Screw, top triple clamp	M8	17 Nm (12.5 lbf ft)
-------------------------	----	---------------------

- Mount and tighten screw ❷.

Guideline

Screw, top steering stem	M8	17 Nm (12.5 lbf ft) Loctite®243™
--------------------------	----	--

Finishing work

- Check the play of the steering head bearing. (🔧 p. 65)
- Remove the motorcycle from the lift stand. (🔧 p. 12)

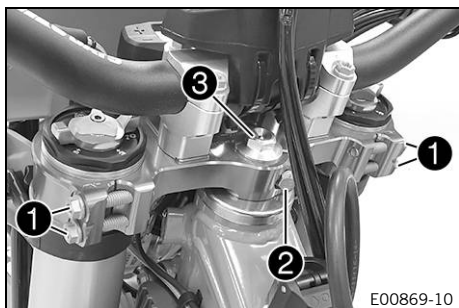

7.1 Handlebar position

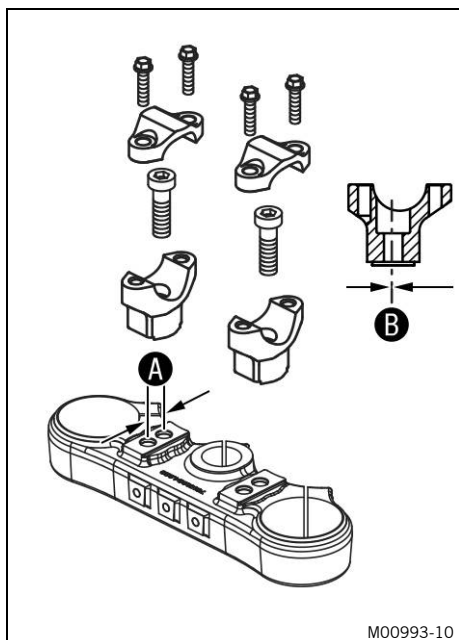

(All standard EXC/XC-W models)

On the upper triple clamp, there are 2 holes at a distance of **A** to each other.

Hole distance A	15 mm (0.59 in)
-----------------	-----------------

The holes on the handlebar support are placed at a distance of **B** from the center.

Hole distance B	3.5 mm (0.138 in)
-----------------	-------------------

The handlebar can be mounted in four different positions. This allows the handlebar to be mounted in the most comfortable position for the rider.

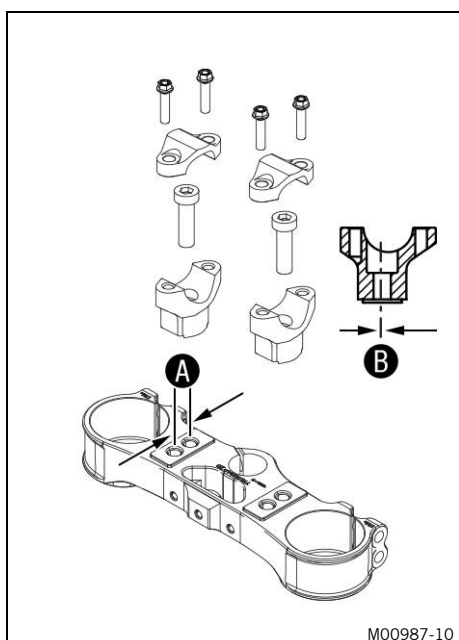

(All Six Days models)

On the upper triple clamp, there are 2 holes at a distance of **A** to each other.

Hole distance A	15 mm (0.59 in)
-----------------	-----------------

The holes on the handlebar support are placed at a distance of **B** from the center.

Hole distance B	3.5 mm (0.138 in)
-----------------	-------------------

The handlebar can be mounted in four different positions. This allows the handlebar to be mounted in the most comfortable position for the rider.

7.2 Adjusting the handlebar position



Warning

Danger of accidents A repaired handlebar poses a safety risk.

If the handlebar is bent or straightened, the material becomes fatigued. The handlebar may break as a result.

- Change the handlebar if the handlebar is damaged or bent.

7 HANDLEBAR, CONTROLS

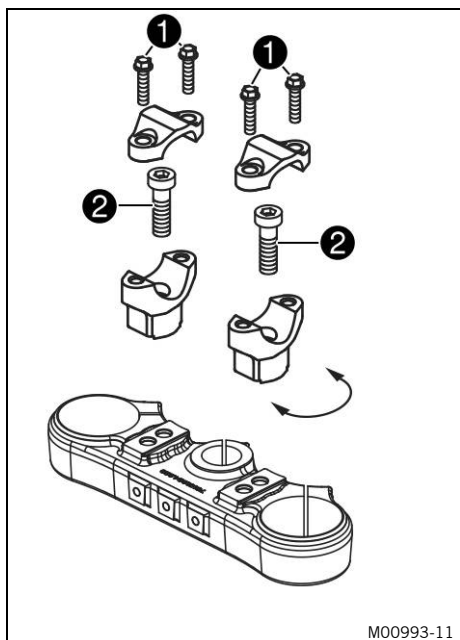

(All standard EXC/XC-W models)

- Remove screws **1**. Take off the handlebar clamps. Remove the handlebar and lay it to one side.

i Info
Cover the components to protect them against damage.
Do not kink the cables and lines.

- Remove screws **2**. Take off the handlebar supports.
- Place the handlebar supports in the required position. Mount and tighten screws **2**.

Guideline

Screw, handlebar support	M10	40 Nm (29.5 lbf ft) Loctite®243™
--------------------------	-----	--

i Info
Position the left and right handlebar supports evenly.

- Position the handlebar.

i Info
Make sure the cables and wiring are positioned correctly.

- Position the handlebar clamps. Mount screws **1** and tighten evenly.

Guideline

Screw, handlebar clamp	M8	20 Nm (14.8 lbf ft)
------------------------	----	------------------------

i Info
Make sure the gap widths are even.

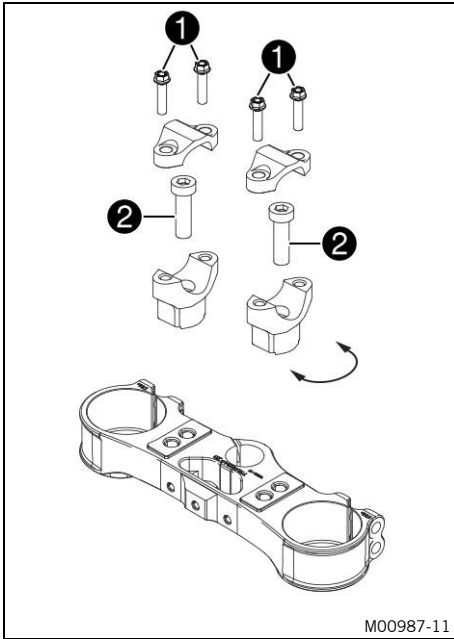

(All Six Days models)

- Remove screws **1**. Take off the handlebar clamps. Remove the handlebar and lay it to one side.

i Info
Cover the components to protect them against damage.
Do not kink the cables and lines.

- Remove screws **2**. Take off the handlebar supports.
- Place the handlebar supports in the required position. Mount and tighten screws **2**.

Guideline

Screw, handlebar support	M10	40 Nm (29.5 lbf ft) Loctite®243™
--------------------------	-----	--

i Info
Position the left and right handlebar supports evenly.

- Position the handlebar.

i Info
Make sure the cables and wiring are positioned correctly.

- Position the handlebar clamps. Mount screws **1** and tighten evenly.

Guideline

Screw, handlebar clamp	M8	20 Nm (14.8 lbf ft)
------------------------	----	------------------------

i Info
Make sure the gap widths are even.

7.3 Adjusting the basic position of the clutch lever



- Adjust the basic position of the clutch lever to your hand size by turning adjusting screw **1**.

i Info
Turn the adjusting screw counterclockwise to decrease the distance between the clutch lever and the handlebar.
Turn the adjusting screw clockwise to increase the distance between the clutch lever and the handlebar. The range of adjustment is limited.
Turn the adjusting screw by hand only, and do not apply any force.
Do not make any adjustments while riding.

7.4 Checking the rubber grip

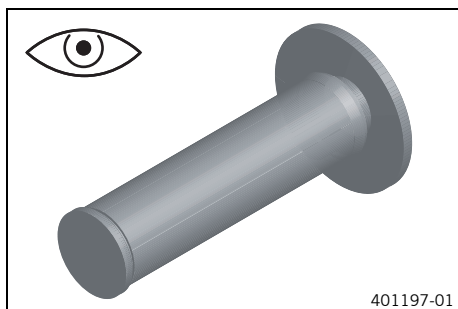

- Check the rubber grips on the handlebar for damage, wear, and looseness.



Info

The rubber grips are vulcanized onto a sleeve on the left and onto the handle tube of the throttle grip on the right. The left sleeve is clamped onto the handlebar. The rubber grip can only be replaced with the sleeve or the throttle tube.

- » If a rubber grip is damaged or worn:
 - Change the rubber grip.

- Check that screw ❶ is firmly seated.

Guideline

Screw, fixed grip	M4	5 Nm (3.7 lbf ft) Loctite®243™
-------------------	----	--

The diamond ❷ must be positioned visibly as shown in the figure.

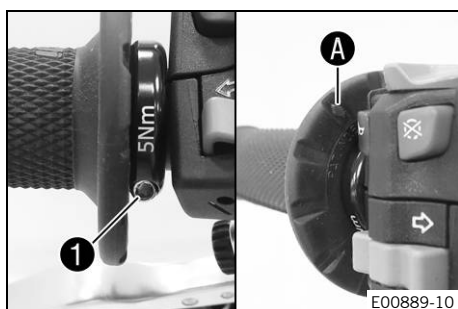

7.5 Checking throttle cable routing

Preparatory work

- Remove the seat. (📖 p. 121)
- Remove the fuel tank. (📖 p. 122)

Main work

- Check throttle cable routing.

Both throttle cables must be routed, side by side, on the back of the handlebars, above the fuel tank bracket on the right of the frame to the throttle valve body. Both throttle cables must be secured behind the fuel tank contact area rubber band.

- » If the throttle cable routing is not as specified:
 - Correct throttle cable routing.

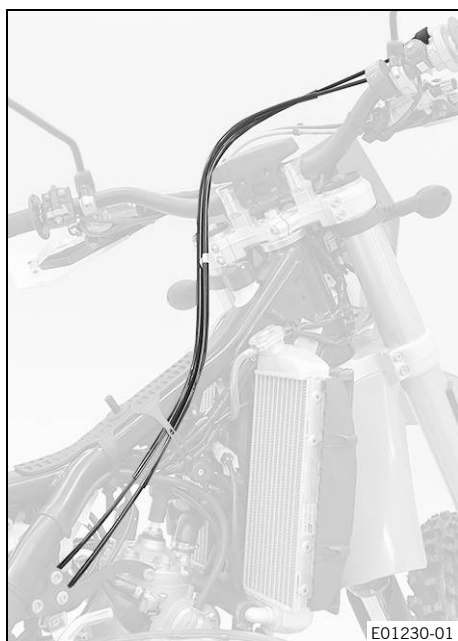

Finishing work

- Install the fuel tank. (📖 p. 123)
- Mount the seat. (📖 p. 121)

7.6 Checking the play in the throttle cable

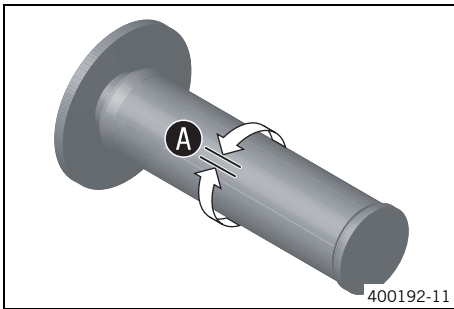

- Check the throttle grip for smooth operation.
- Turn the handlebar as far as possible to the right. Turn the throttle grip back and forth slightly and determine the play in throttle cable **A**.

Play in throttle cable	3 ... 5 mm (0.12 ... 0.2 in)
------------------------	------------------------------

- » If the throttle cable play does not meet the specified value:
 - Adjust the play in the throttle cable. (📖 p. 71)



Danger

Danger of poisoning Exhaust gases are toxic and inhaling them may result in unconsciousness and death.

- Always make sure there is sufficient ventilation when running the engine.
- Use an effective exhaust extraction system when starting or running the engine in an enclosed space.

- Start the engine and let it run idle. Move the handlebar to and fro over the entire steering range.

The idle speed must not change.

- » If the idle speed changes:
 - Adjust the play in the throttle cable. (📖 p. 71)



7.7 Adjusting the play in the throttle cable



Info

If the correct routing of the throttle cables has already been secured, the fuel tank does not need to be removed.

Preparatory work

- Remove the seat. (📖 p. 121)
- Remove the fuel tank. (📖 p. 122)
- Check throttle cable routing. (📖 p. 70)

Main work

- Move the handlebar to the straight-ahead position.
- Push back sleeve **1**.
- Loosen nut **2**.
- Turn adjusting screw **3** in as far as possible.
- Loosen nut **4**.
- Turn adjusting screw **5** in as far as possible.
- Turn adjusting screw **3** so that there is play in the throttle cable at the throttle grip.

Guideline

Play in throttle cable	3 ... 5 mm (0.12 ... 0.2 in)
------------------------	------------------------------

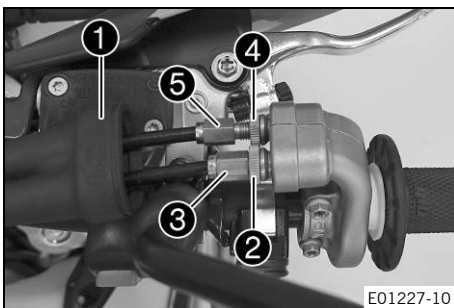

- Unscrew the adjusting screw ⑤ until the smooth operation or play in throttle cable is worsened.
- Turn the adjusting screw ⑤ approx. two turns further.
- Tighten nut ④.
- Tighten nut ②.
- Slide on sleeve ①.
- Check the throttle grip for smooth operation.

Finishing work

- Check the play in the throttle cable. (📖 p. 71)

7.8 Setting the characteristic map of the throttle response



Info

On the throttle grip, the characteristic map of the throttle response is changed by changing the guide plate.

A guide plate with a different characteristic map is supplied.

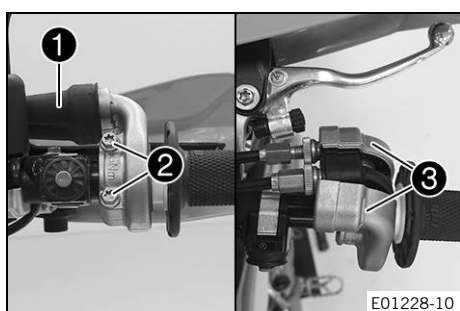

Main work

- Push back sleeve ①.
- Remove screws ② and half-shells ③.
- Detach the throttle cables and take off the grip tube.

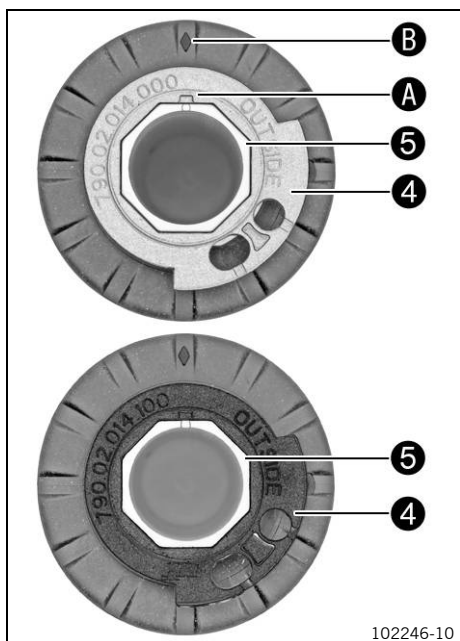

- Remove guide plate ④ from handle tube ⑤.
- Position the required guide plate on the grip tube.

Guideline

The label **OUTSIDE** must be visible. Marking **A** must be positioned at marking **B**.

Grey guide plate (79002014000)

Alternative 1

Black guide plate (79002014100)



Info

The gray guide plate opens the throttle valve more slowly.
The black guide plate opens the throttle valve more quickly.
The gray guide plate is mounted upon delivery.

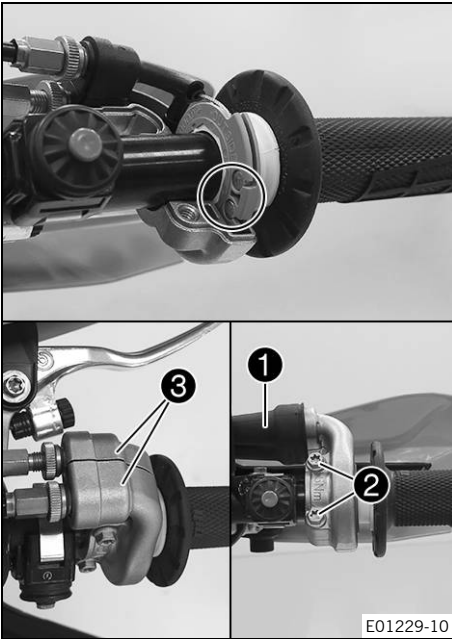

- Clean the outside of the handlebar and the inside of the grip tube. Mount the grip tube on the handlebar.
- Attach the throttle cables to the guide plate and route correctly.
- Position half-shells **3**, mount and tighten screws **2**.

Guideline

Screw, throttle grip	M6	5 Nm (3.7 lbf ft)
----------------------	----	-------------------

- Slide on sleeve **1** and check the throttle grip for ease of movement.

Finishing work

- Check the play in the throttle cable. (📖 p. 71)



8.1 Checking the frame

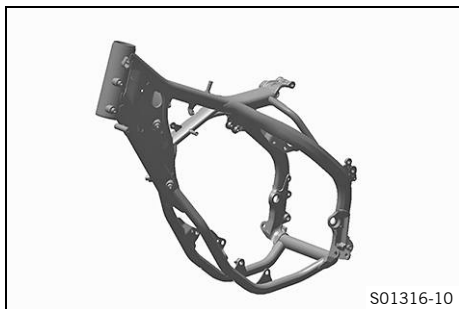

- Check the frame for cracks and deformation.
 - » If the frame exhibits cracks or deformation due to a mechanical impact:
 - Change the frame.



Info

Always replace a frame that has been damaged due to a mechanical impact. Repair of the frame is not authorized by KTM.

8.2 Removing the engine guard (All Six Days models)

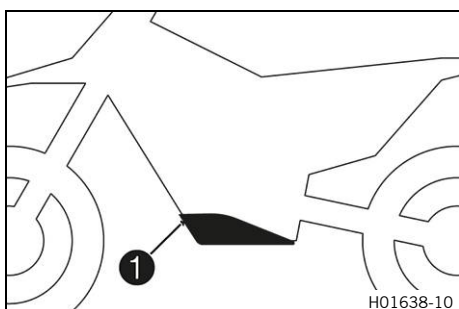

- Remove screws ❶ and engine guard.

8.3 Installing the engine guard (All Six Days models)

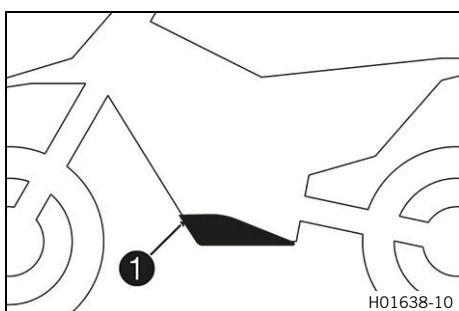

- Attach the engine guard on the frame at the rear and swing up at the front.
- Mount and tighten screws ❶.

Guideline

Remaining screws, chassis	M6	10 Nm (7.4 lbf ft)
---------------------------	----	--------------------

8.4 Changing the footrests

Condition

The frame protectors have been removed on the left and right.

Left footrest

- Raise the motorcycle with a lift stand. (📖 p. 12)
- Remove split pin ❶ and take off the washer.

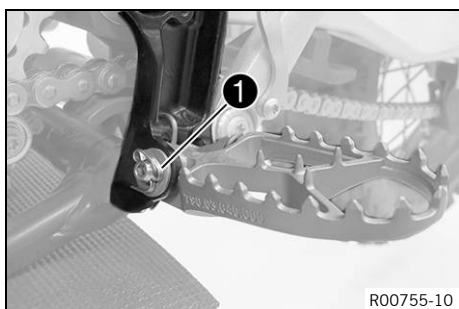

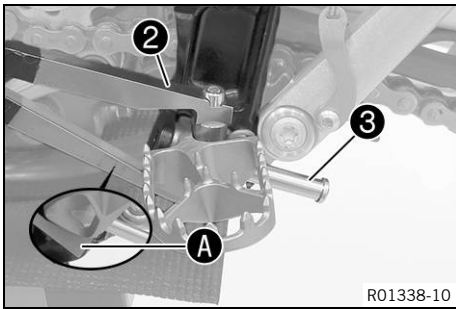

- Press the spring with special tool ②.

Footrest spring plier (79029083000) (📖 p. 371)

- ✓ The special tool is applied to area A on the footrest.
- Remove pin ③.

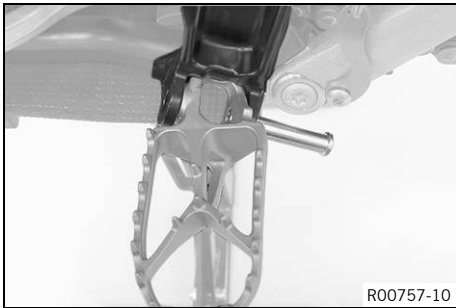

- Position the new footrest and pin.



Info

Only insert the pin to the extent that the spring can still be mounted.

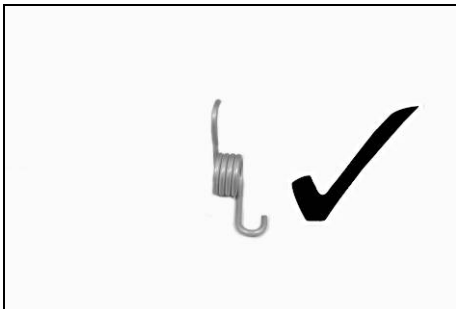

- Position spring as shown.

- ✓ Spring B engages in area C.

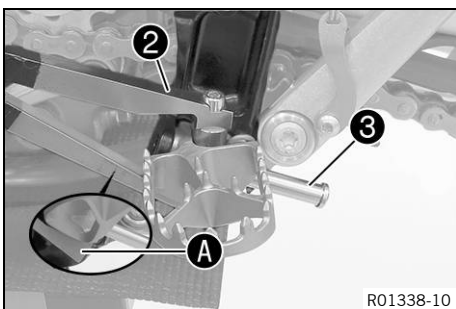
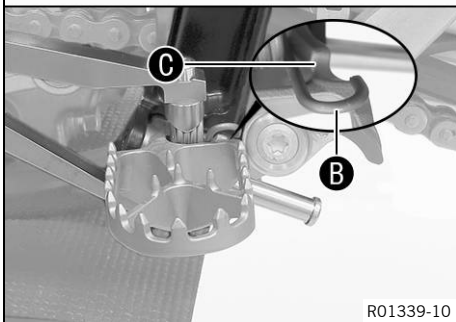

- Press the spring with special tool ②.

Footrest spring plier (79029083000) (📖 p. 371)

- ✓ The special tool is applied to area A on the footrest.
- Mount pin ③.

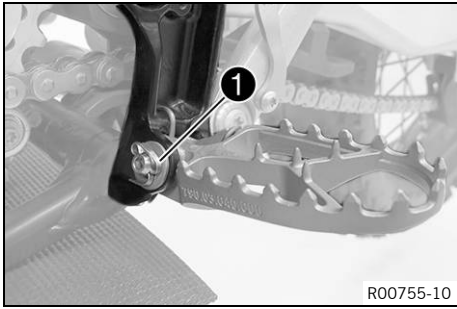

- Mount the washer and split pin ①.
- Remove the motorcycle from the lift stand. (📖 p. 12)

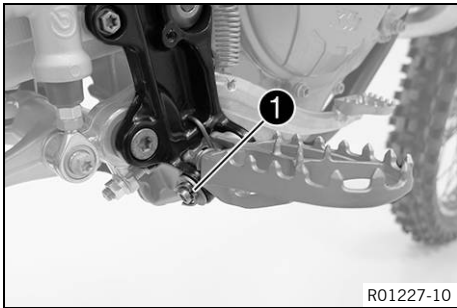

Right footrest

- Remove split pin ① and take off the washer.

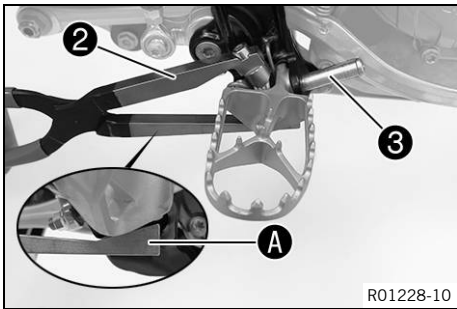

- Press the spring with special tool ②.

Footrest spring plier (79029083000) (📖 p. 371)

- ✓ The special tool is applied to area A on the footrest.

- Remove pin ③.



- Position the new footrest and pin.

i Info
Only insert the pin to the extent that the spring can still be mounted.

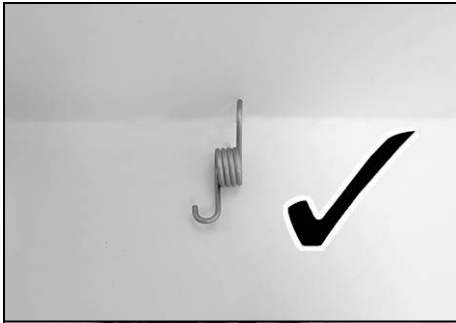

- Position spring as shown.
- ✓ Spring **B** engages in area **C**.

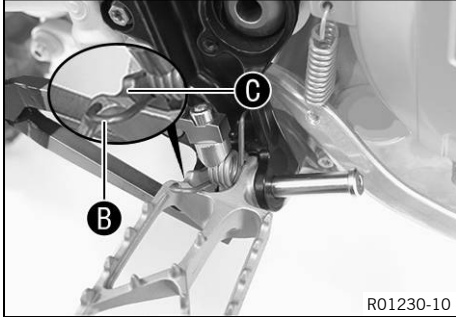

R01230-10

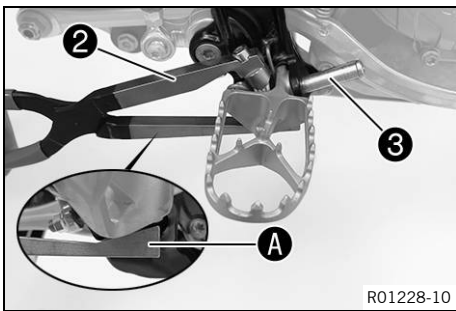

R01228-10

- Press the spring with special tool **2**.
- Footrest spring plier (79029083000) (📖 p. 371)
- ✓ The special tool is applied to area **A** on the footrest.
 - Mount pin **3**.

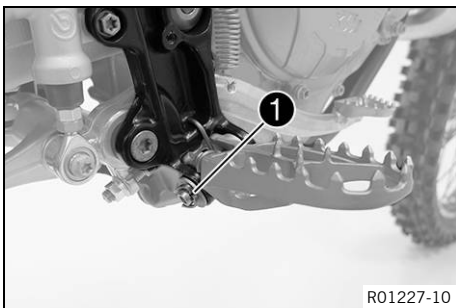

R01227-10

- Mount the washer and split pin **1**.



9.1 Adjusting the high-speed compression damping of the shock absorber



Caution

Risk of injury Parts of the shock absorber will move around if the shock absorber is detached incorrectly. The shock absorber is filled with highly compressed nitrogen.

- Please follow the description provided.



Info

The effect of the high-speed setting can be seen in fast compression of the shock absorber.

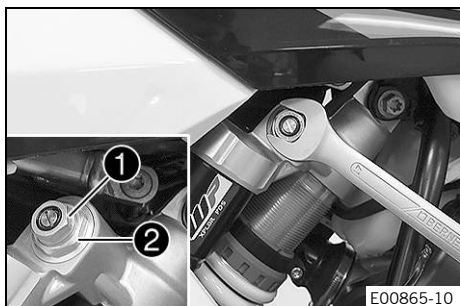

- Using an open end wrench, turn adjusting screw **1** clockwise all the way.



Info

Do not loosen fitting **2**!

- Turn counterclockwise by the number of turns corresponding to the shock absorber type.

Guideline

Compression damping, high-speed	
Comfort	2.5 turns
Standard	2 turns
Sport	1 turn



Info

Turn clockwise to increase damping; turn counterclockwise to reduce damping.

9.2 Adjusting the low-speed compression damping of the shock absorber



Caution

Risk of injury Parts of the shock absorber will move around if the shock absorber is detached incorrectly. The shock absorber is filled with highly compressed nitrogen.

- Please follow the description provided.



Info

The effect of the low-speed setting can be seen in slow to normal compression of the shock absorber.

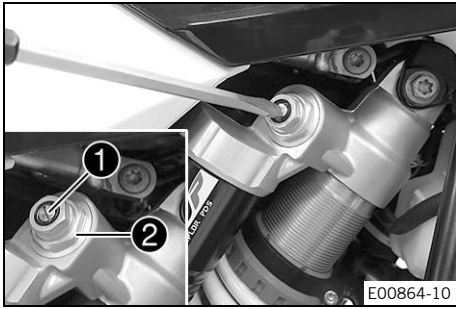

- Turn adjusting screw ❶ clockwise with a screwdriver as far as the last perceptible click.

i Info
Do not loosen fitting ❷!

- Turn counterclockwise by the number of clicks corresponding to the shock absorber type.

Guideline

Compression damping, low-speed	
Comfort	18 clicks
Standard	15 clicks
Sport	12 clicks

i Info
Turn clockwise to increase damping; turn counterclockwise to reduce damping.

9.3 Adjusting the rebound damping of the shock absorber

⚠ Caution
Risk of injury Parts of the shock absorber will move around if the shock absorber is detached incorrectly. The shock absorber is filled with highly compressed nitrogen.
- Please follow the description provided.

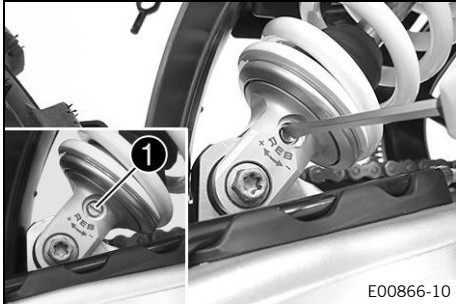

- Turn adjusting screw ❶ clockwise up to the last perceptible click.
- Turn counterclockwise by the number of clicks corresponding to the shock absorber type.

Guideline

Rebound damping	
Comfort	18 clicks
Standard	15 clicks
Sport	12 clicks

i Info
Turn clockwise to increase damping; turn counterclockwise to reduce damping.

9.4 Measuring the rear wheel dimension unloaded

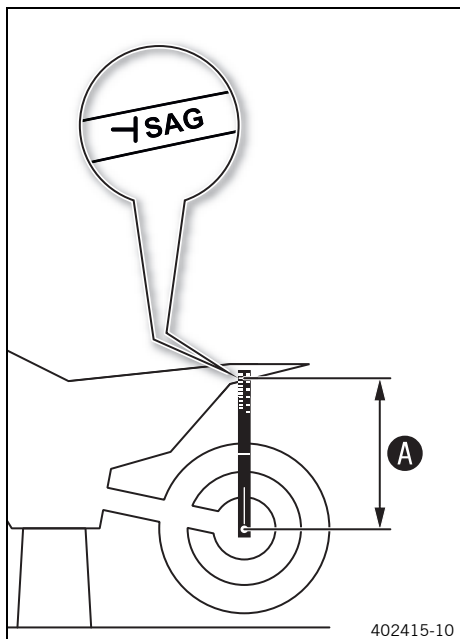

Preparatory work

- Raise the motorcycle with a lift stand. (🔧 p. 12)

Main work

- Position the sag gauge in the rear axle and measure the distance to marking **SAG** on the rear fender.

Sag gauge (00029090100)

Pin for sag gauge (00029990010)

- Note down the value as dimension **A**.

Finishing work

- Remove the motorcycle from the lift stand. (🔧 p. 12)

9.5 Checking the static sag of the shock absorber

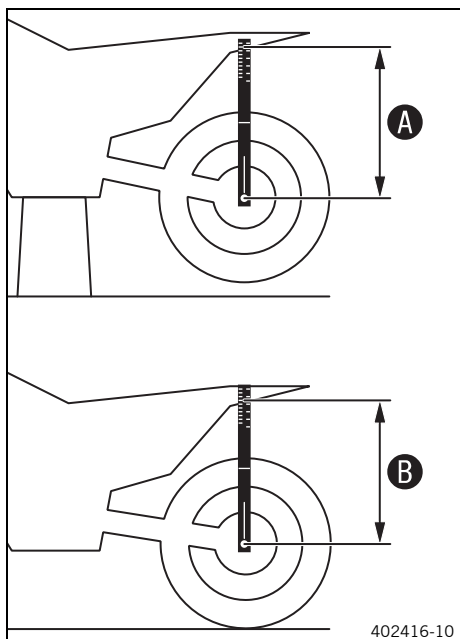

- Measure dimension **A** of rear wheel unloaded. (🔧 p. 80)
- Hold the motorcycle upright with the aid of an assistant.
- Again measure the distance between the rear axle and marking **SAG** on the rear fender using the sag gauge.
- Note down the value as dimension **B**.

Info

The static sag is the difference between measurements **A** and **B**.

- Check the static sag.

Static sag	35 mm (1.38 in)
------------	-----------------

- » If the static sag is less or more than the specified value:
 - Adjust the spring preload of the shock absorber. (🔧 p. 81)

9.6 Checking the riding sag of the shock absorber

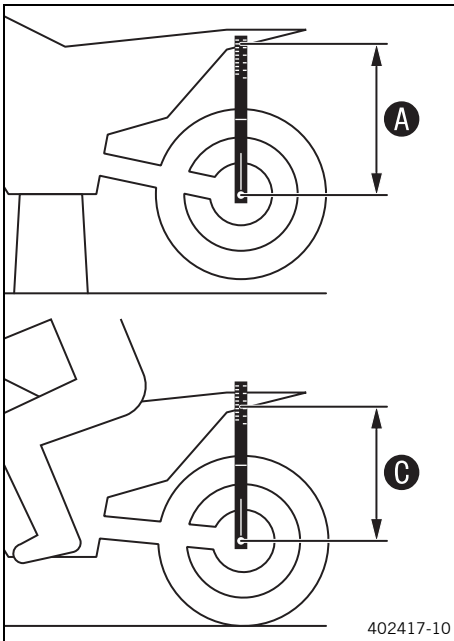

- Measure dimension **A** of rear wheel unloaded. (📖 p. 80)
- With another person holding the motorcycle, the rider, wearing full protective clothing, sits on the seat in a normal sitting position (feet on footrests) and bounces up and down a few times.
 - ✓ The rear wheel suspension levels out.
- Another person again measures the distance between the rear axle and marking **SAG** on the rear fender using the sag gauge.
- Note down the value as dimension **C**.



Info

The riding sag is the difference between measurements **A** and **C**.

- Check the riding sag.

Riding sag	110 mm (4.33 in)
------------	------------------

- » If the riding sag differs from the specified measurement:
 - Adjust the riding sag. (📖 p. 82)

9.7 Adjusting the spring preload of the shock absorber



Caution

Risk of injury Parts of the shock absorber will move around if the shock absorber is detached incorrectly. The shock absorber is filled with highly compressed nitrogen.

- Please follow the description provided.



Info

Before changing the spring preload, make a note of the present setting, e.g., by measuring the spring length.

Preparatory work

- Raise the motorcycle with a lift stand. (📖 p. 12)
- Remove the shock absorber. (📖 p. 83)
- After removing the shock absorber, clean it thoroughly.

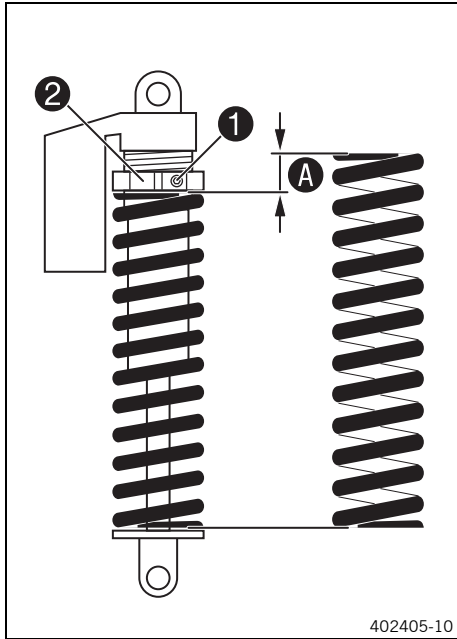

Main work

- Loosen screw ①.
- Turn adjusting ring ② until the spring is no longer under tension.

Holding wrench (90129051000) (📖 p. 371)

- Measure the overall spring length while the spring is not under tension.
- Tighten the spring by turning adjusting ring ② to measurement A.

Guideline

Spring preload	8 mm (0.31 in)
----------------	----------------

Info

Depending on the static sag and/or the riding sag, it may be necessary to increase or decrease the spring preload.

- Tighten screw ①.

Guideline

Screw, shock absorber adjusting ring	M5	5 Nm (3.7 lbf ft)
--------------------------------------	----	-------------------

Finishing work

- Install the shock absorber. (📖 p. 83)
- Remove the motorcycle from the lift stand. (📖 p. 12)

9.8 Adjusting the riding sag

Preparatory work

- Raise the motorcycle with a lift stand. (📖 p. 12)
- Remove the shock absorber. (📖 p. 83)
- After removing the shock absorber, clean it thoroughly.

Main work

- Choose and mount a suitable spring.

Guideline

Spring rate	
Weight of rider: 65 ... 75 kg (143 ... 165 lb.)	57 ... 63 N/mm (325 ... 360 lb/in)
Weight of rider: 75 ... 85 kg (165 ... 187 lb.)	60 ... 66 N/mm (343 ... 377 lb/in)
Weight of rider: 85 ... 95 kg (187 ... 209 lb.)	63 ... 69 N/mm (360 ... 394 lb/in)

Info

The spring rate is shown on the outside of the spring.

Finishing work

- Install the shock absorber. (📖 p. 83)
- Remove the motorcycle from the lift stand. (📖 p. 12)
- Check the static sag of the shock absorber. (📖 p. 80)

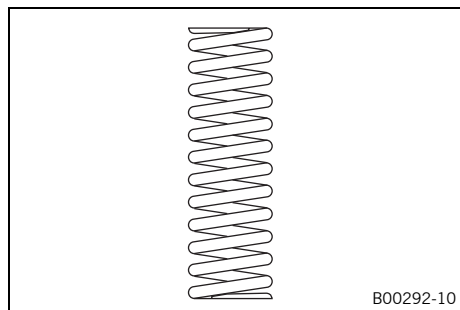

- Check the riding sag of the shock absorber. (📖 p. 81)
- Adjust the rebound damping of the shock absorber. (📖 p. 79)

9.9 Removing the shock absorber

Preparatory work

- Raise the motorcycle with a lift stand. (📖 p. 12)

Main work

- Remove screw ① and lower the rear wheel with the swingarm as far as possible without blocking the rear wheel. Secure the rear wheel in this position.
- Remove screw ②, push splash protector ③ to the side, and remove the shock absorber.

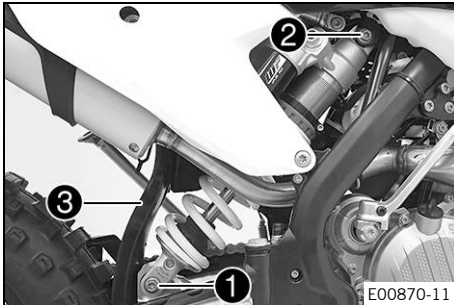

9.10 Installing the shock absorber

Main work

- Push splash protector ① to the side and position the shock absorber. Mount and tighten screw ②.

Guideline

Screw, top shock absorber	M12	80 Nm (59 lbf ft) Loctite®2701™
---------------------------	-----	---

- Mount and tighten screw ③.

Guideline

Screw, bottom shock absorber	M12	80 Nm (59 lbf ft) Loctite®2701™
------------------------------	-----	---

Info

The heim joint for the shock absorber at the swingarm is Teflon-coated. It must not be greased with grease or with other lubricants. Lubricants dissolve the Teflon coating, thereby drastically reducing the service life.

Finishing work

- Remove the motorcycle from the lift stand. (📖 p. 12)

9.11 Servicing the shock absorber



Caution

Risk of injury Parts of the shock absorber will move around if the shock absorber is detached incorrectly. The shock absorber is filled with highly compressed nitrogen.

- Please follow the description provided.

Condition

The shock absorber has been removed.

9 SHOCK ABSORBER, SWINGARM

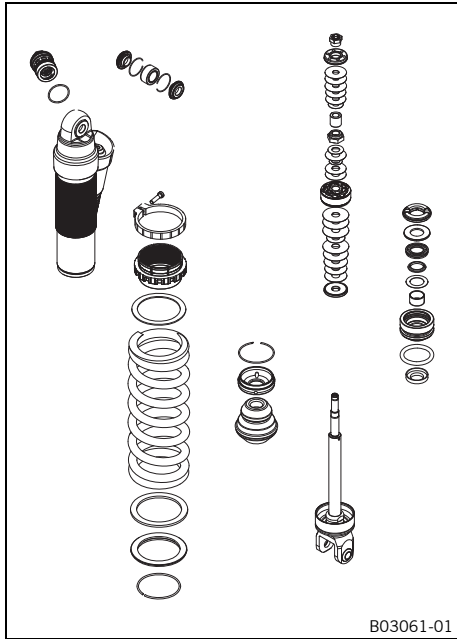

- Remove the spring. (📖 p. 84)
- Disassemble the damper. (📖 p. 85)
- Disassemble the piston rod. (📖 p. 87)
- Disassemble the seal ring retainer. (📖 p. 86)
- Check the damper. (📖 p. 89)
- Remove the heim joint. (📖 p. 90)
- Install the heim joint. (📖 p. 91)
- Assemble the seal ring retainer. (📖 p. 91)
- Assemble the piston rod. (📖 p. 92)
- Assemble the damper. (📖 p. 94)
- Install the spring. (📖 p. 100)

9.12 Removing the spring

Condition

The shock absorber has been removed.

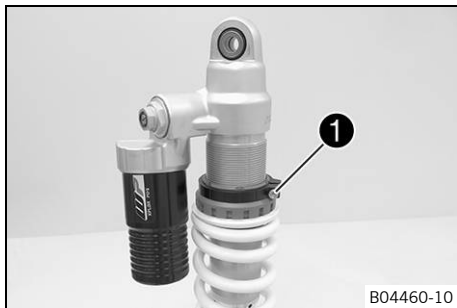

- Clamp the shock absorber into the vise.

Guideline

Use soft jaws.

- Measure and note the spring length while the spring is under tension.
- Loosen screw ①.
- Turn the adjusting ring until the spring is completely without tension.

Holding wrench (90129051000) (📖 p. 371)

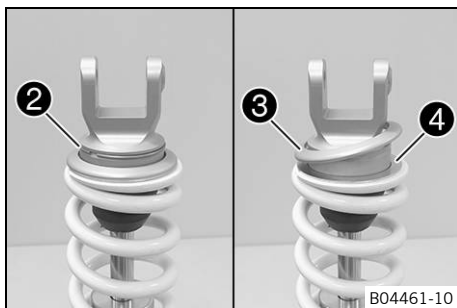

- Remove lock ring ②.
- Remove spring retainer ③.
- Remove washer ④.

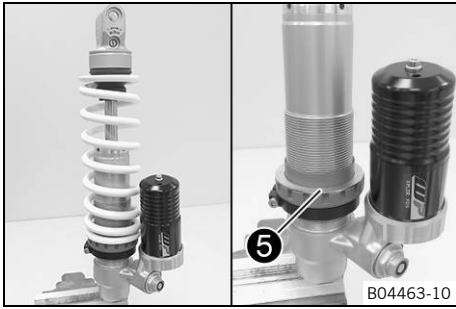

- Remove the spring.
- Remove washer **5**.

9.13 Disassembling the damper

Preparatory work

- Remove the spring. (📖 p. 84)

Main work

- Make a note of present state of rebound **1** and compression damping **2**.
- Open the adjusters of the rebound and compression damping completely.

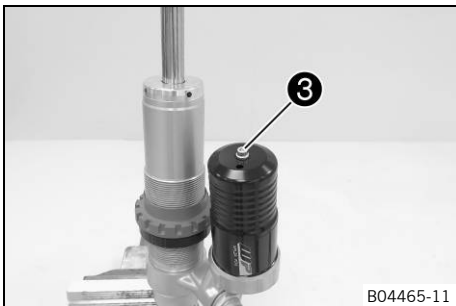
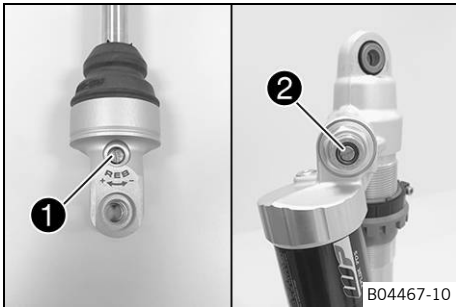

- Slowly open screw **3**.
✓ The nitrogen pressure dissipates.
- Remove the screw with the O-ring.

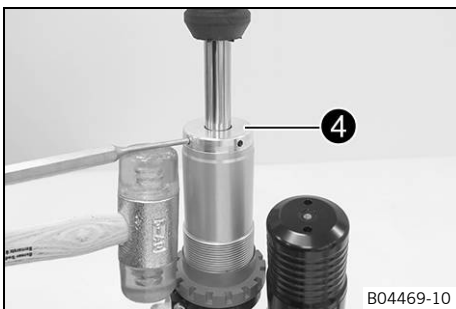

- Remove locking cap **4**.

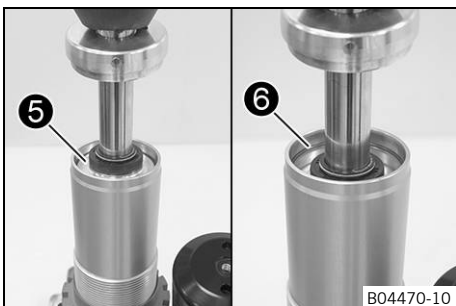

- Push in seal ring retainer **5**.
- Remove lock ring **6**.



Info

Check inner surface; do not scratch. Remove any burrs with sandpaper if needed.

9 SHOCK ABSORBER, SWINGARM

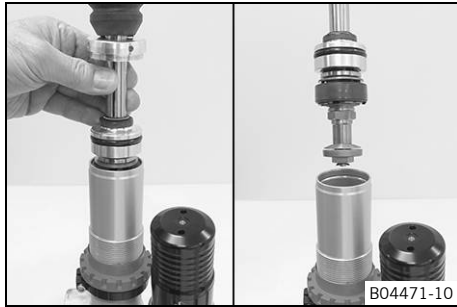

- Remove the piston rod.

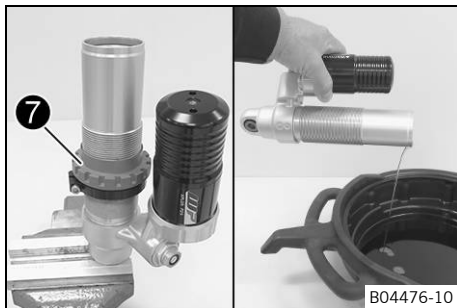

- Remove adjusting ring 7 with the clamping ring.
- Drain the oil.

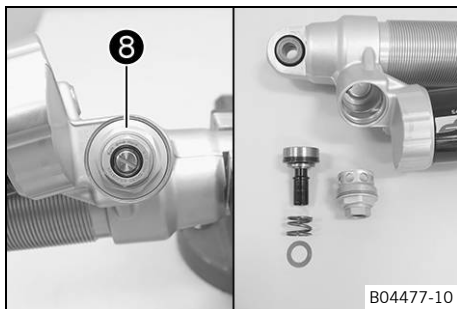

- Remove compression adjuster 8. Remove the washer, spring, and piston.

9.14 Disassembling the seal ring retainer

Preparatory work

- Remove the spring. (📖 p. 84)
- Disassemble the damper. (📖 p. 85)
- Disassemble the piston rod. (📖 p. 87)

Main work

- Remove rebound rubber 1.
- Remove washer 2.

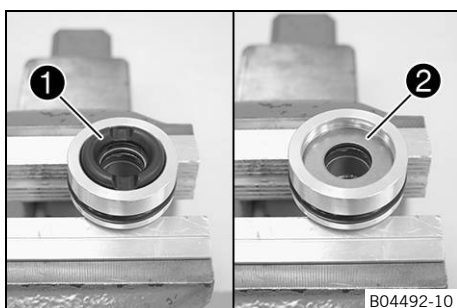

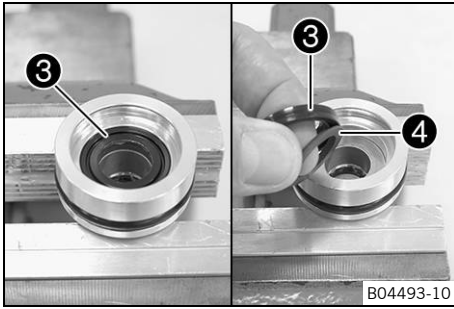

- Remove seal ring ③.
- Remove washer ④ from seal ring ③.

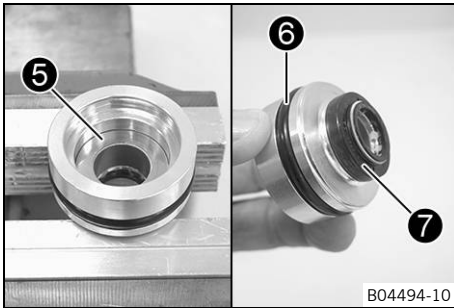

- Remove washer ⑤.
- Remove O-ring ⑥.
- Remove dust boot ⑦.

9.15 Disassembling the piston rod

Preparatory work

- Remove the spring. (📖 p. 84)
- Disassemble the damper. (📖 p. 85)

Main work

- Clamp the piston rod with the fork in the bench vise.

Guideline

Use soft jaws.

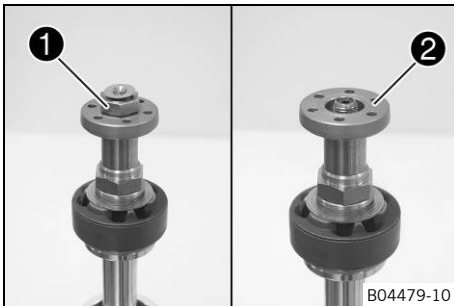

- Remove nut ①.
- Remove piston ②.

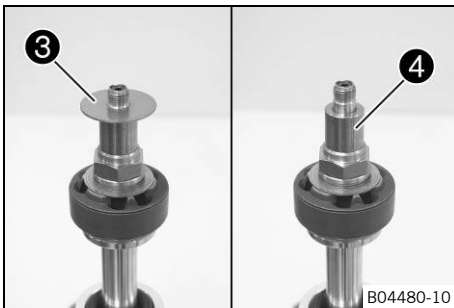

- Remove compression shim stack ③.

i Info

Guide the compression shim stack onto a screwdriver and put them to one side together.

- Remove bushing ④.

9 SHOCK ABSORBER, SWINGARM

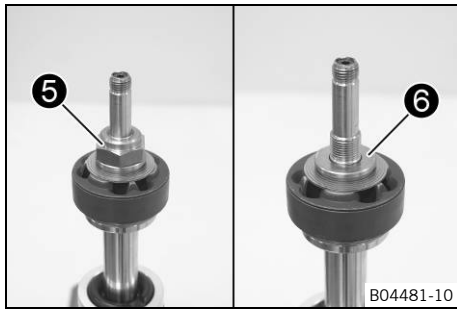

- Remove nut 5.
- Remove washer 6.

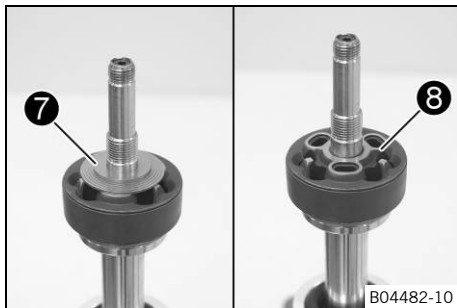

- Remove rebound shim stack 7.



Info

Guide the rebound shim stack onto a screwdriver and put them to one side together.

- Remove piston 8.

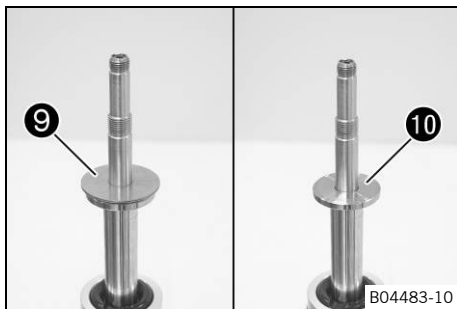

- Remove compression shim stack 9.



Info

Guide the compression shim stack onto a screwdriver and put them to one side together.

- Remove rebound washer 10.

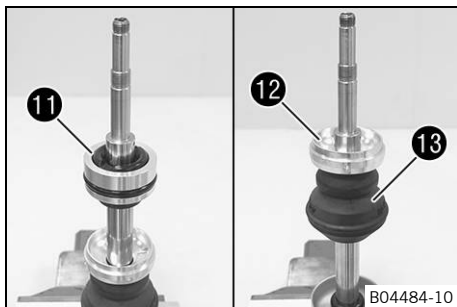

- Remove seal ring retainer 11.
- Remove locking cap 12 and rubber buffer 13.

9.16 Replacing the pilot bushing

Preparatory work

- Remove the spring. (📖 p. 84)
- Disassemble the damper. (📖 p. 85)
- Disassemble the piston rod. (📖 p. 87)
- Disassemble the seal ring retainer. (📖 p. 86)

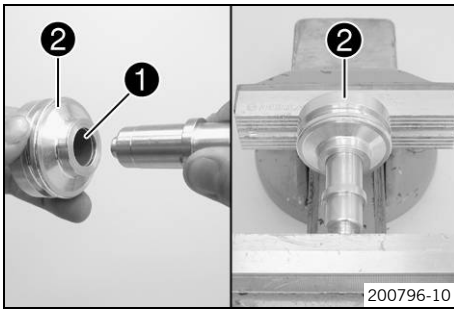

Main work

- Press pilot bushing 1 out of seal ring retainer 2 using the special tool.

Pressing tool (T1504) (📖 p. 375)

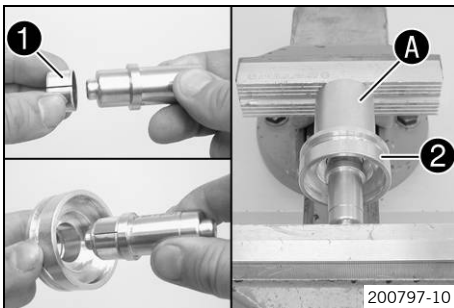

- Slide the new pilot bushing 1 onto the special tool.

Pressing tool (T1504) (📖 p. 375)

- Position the pilot bushing in the seal ring retainer using the special tool.

Pressing tool (T1504) (📖 p. 375)

- Support seal ring retainer 2 with the sleeve A of the special tool. Press the pilot bushing all the way in.

Mounting tool (T150S) (📖 p. 375)

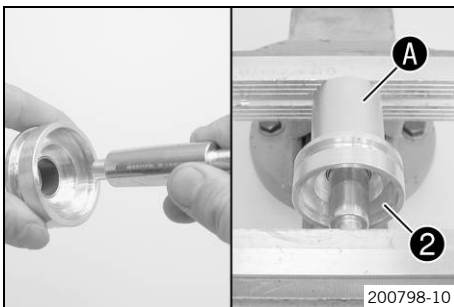

- Lubricate the special tool.

Shock absorber fluid (SAE 2.5) (50180751S1) (📖 p. 359)

Calibrating unit (T1205) (📖 p. 372)

- Support seal ring retainer 2 with the sleeve A of the special tool.

Mounting tool (T150S) (📖 p. 375)

- Press the special tool through the new pilot bushing.

Calibrating unit (T1205) (📖 p. 372)

✓ The pilot bushing is to be calibrated.

Finishing work

- Assemble the seal ring retainer. (📖 p. 91)

9.17 Checking the damper



Condition

The damper has been disassembled.

- Measure the inside diameter on both ends and in the middle of the damper cartridge.

Damper cartridge

Diameter	46.10 mm (1.815 in)
----------	---------------------

- » If the measured value is greater than the specified value:
 - Replace the damper cartridge.
- Check the damper cartridge for damage and wear.
 - » If there is damage or wear:
 - Replace the damper cartridge.
- Check the heim joint for damage and wear.
 - » If there is damage or wear:
 - Replace the heim joint.

9 SHOCK ABSORBER, SWINGARM

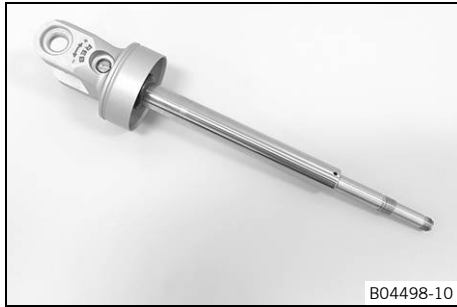

- Measure the diameter of the piston rod.

Piston rod	
Diameter	≥ 17.95 mm (≥ 0.7067 in)

- » If the measured value is smaller than the specified value:

- Replace the piston rod.

- Measure the run-out of the piston rod.

Piston rod	
Run-out	≤ 0.03 mm (≤ 0.0012 in)

- » If the measured value is greater than the specified value:

- Replace the piston rod.

- Check the piston rod for damage and wear.

- » If there is damage or wear:

- Replace the piston rod.

- Check the piston rings for damage and wear.

- » If damage or a bronze-colored surface is visible:

- Replace the piston rings.



9.18 Removing the heim joint

Condition

The shock absorber has been removed.

- Clamp the shock absorber into the vise.

Guideline

Use soft jaws.

- Remove both collar bushings ① of the heim joint with a special tool.

Drift (T120) (📖 p. 372)

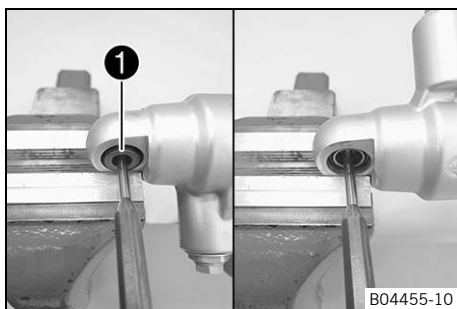

- Press the heim joint against a lock ring using the special tool.

Pressing tool (T1207S) (📖 p. 373)

- Remove second lock ring ②.

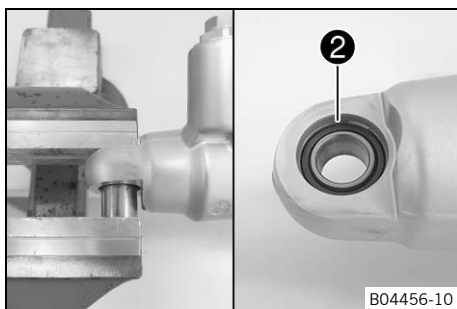

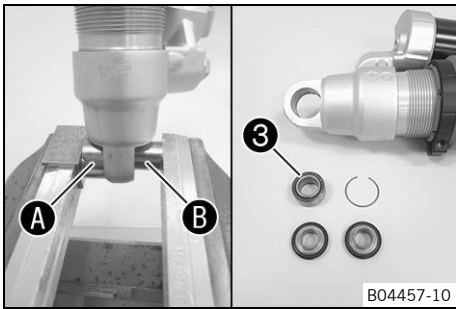

- Place special tool **A** underneath and press out heim joint **3** using special tool **B**.

Pressing tool (T1207S) (📖 p. 373)

9.19 Installing the heim joint

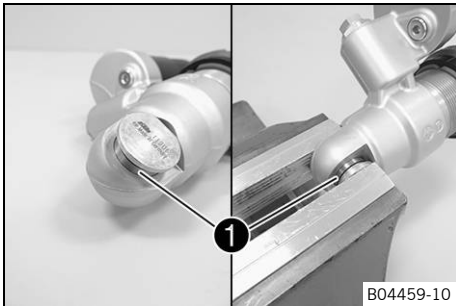

- Position new heim joint **1** and the special tool in the bench vise.

Guideline

Use soft jaws.

Pressing tool (T1206) (📖 p. 373)

- Press the heim joint all the way in.

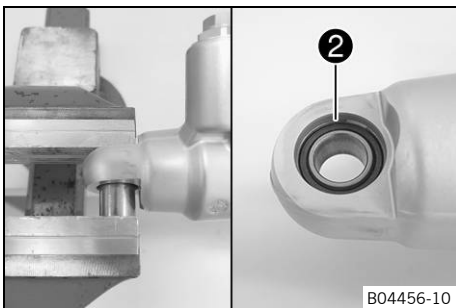

- Press the heim joint against the lock ring using the special tool.

Pressing tool (T1207S) (📖 p. 373)

- Mount second lock ring **2**.

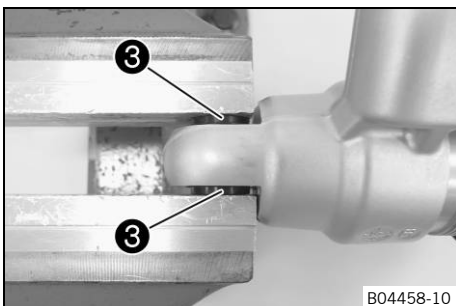

- Position both collar bushings **3** and press in.

9.20 Assembling seal ring retainer

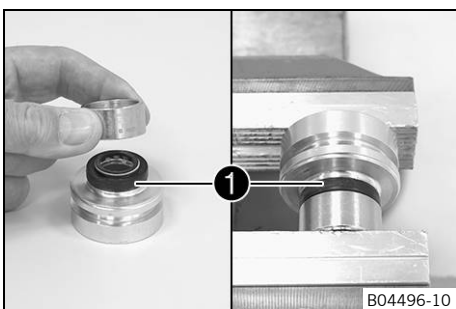

- Mount dust boot **1** with the special tool.

Mounting sleeve (T1204) (📖 p. 372)

- Grease the sealing lip of the dust boot.

Lubricant (T625) (📖 p. 360)

9 SHOCK ABSORBER, SWINGARM

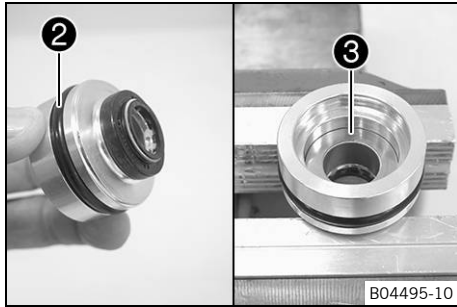

- Grease the O-ring groove.

Lubricant (T158) (📖 p. 360)

- Mount O-ring ②.
- Mount washer ③.

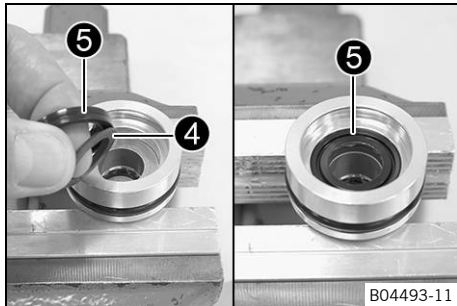

- Position washer ④ on seal ring ⑤.
- Grease the seal ring and mount with the washer facing downward.

Lubricant (T14034) (📖 p. 360)

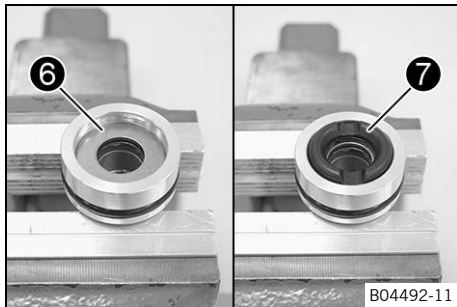

- Mount washer ⑥.
- Mount rebound rubber ⑦.

9.21 Assembling the piston rod

Preparatory work

- Assemble the seal ring retainer. (📖 p. 91)

Main work

- Clamp the piston rod with the fork in the bench vise.

Guideline

Use soft jaws.

- Mount rubber buffer ① and locking cap ②.
- Position the special tool on the piston rod.

Mounting sleeve (T1554) (📖 p. 376)

- Grease the dust boot and slide the seal ring retainer ③ onto the piston rod.

Lubricant (T625) (📖 p. 360)

- Remove the special tool.

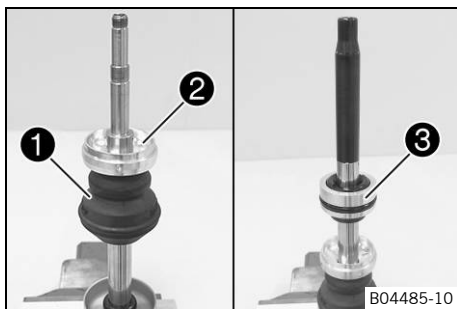

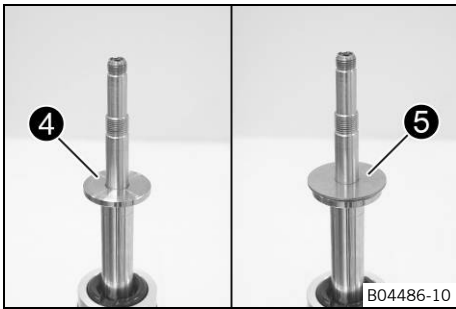

- Mount rebound washer ④.
- Mount compression shim stack ⑤ with the smaller washers facing downward.

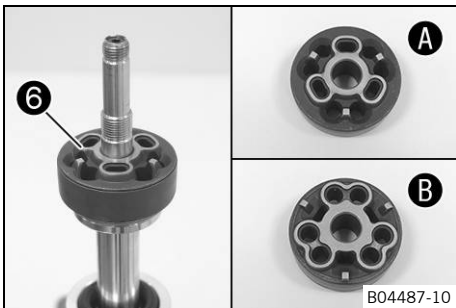

- Clean piston ⑥.
- Mount the piston.

Guideline

View A	of piston from above
View B	of piston from below

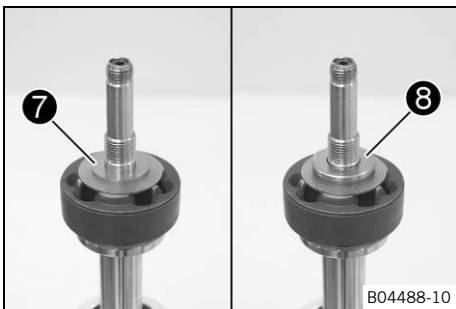

- Mount rebound shim stack ⑦ with the smaller washers facing upward.
- Mount washer ⑧.

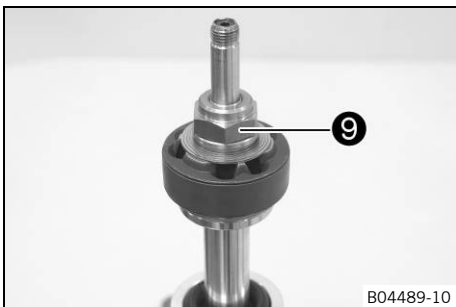

- Mount and tighten nut ⑨ with the collar facing upward.

Guideline

Nut, damper piston	M12x1	40 Nm (29.5 lbf ft)
--------------------	-------	---------------------

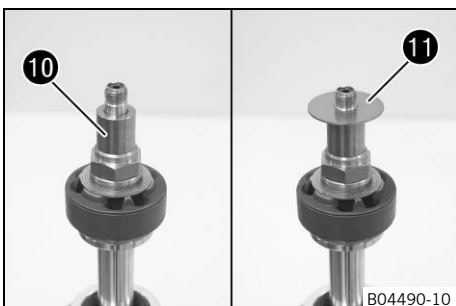

- Mount bushing ⑩.
- Mount compression shim stack ⑪ with the smaller washers facing downward.

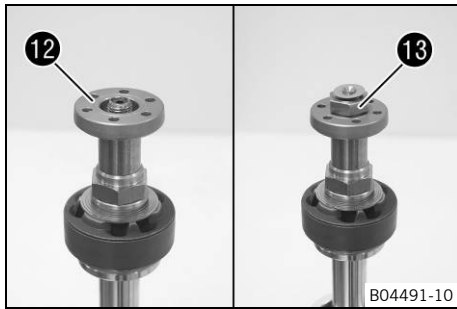

- Position piston **12** with the groove facing upward.
- Mount and tighten nut **13**.

Guideline

Nut, piston rod	M10x1	30 Nm (22.1 lbf ft) Loctite®2701™
-----------------	-------	---

9.22 Assembling the damper

Preparatory work

- Assemble the seal ring retainer. (📖 p. 91)
- Assemble the piston rod. (📖 p. 92)

Main work

- Lubricate the O-rings of the compression adjuster.

Lubricant (T158) (📖 p. 360)

- Lubricate the thread.

Lubricant (T159) (📖 p. 360)

- Mount the piston with the spring and washer.
- Mount and tighten compression adjuster **1**.

Guideline

Compression adjuster	M31x1	35 Nm (25.8 lbf ft)
----------------------	-------	---------------------

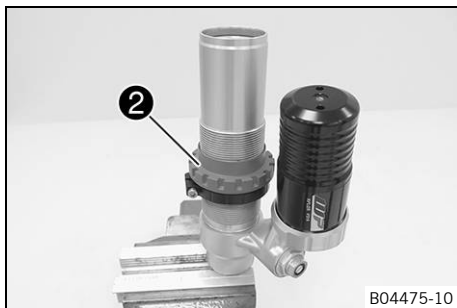
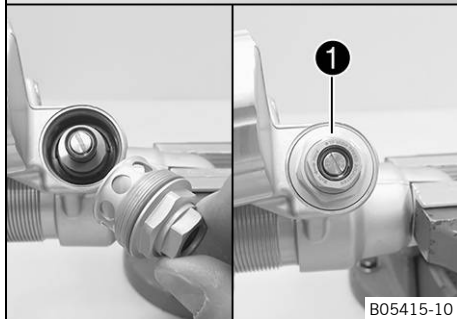

- Mount adjusting ring **2** with the clamping ring.

i Info

The adjusting ring cannot be mounted after the piston rod has been mounted.

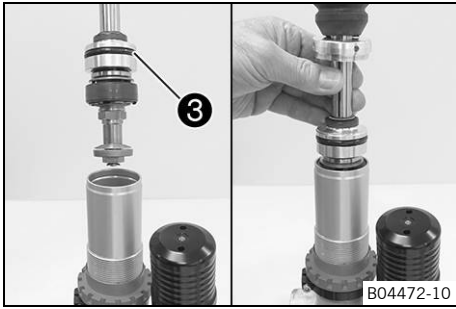

- Fill the damper cartridge about half full.

Shock absorber fluid (SAE 2.5) (50180751S1) (📖 p. 359)

- Lubricate O-ring ③ of the seal ring retainer.

Lubricant (T158) (📖 p. 360)

- Mount the piston rod carefully.

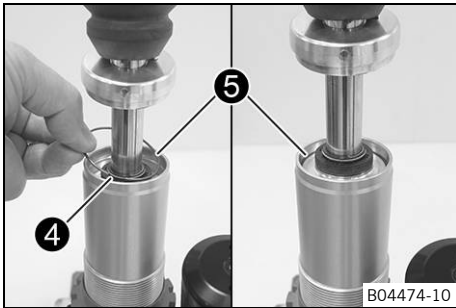

- Mount seal ring retainer ④ and slide it under the ring groove.
- Mount lock ring ⑤.



Info

Do not scratch the inside surface.

- Pull out the piston rod until the seal ring retainer is flush with the lock ring.

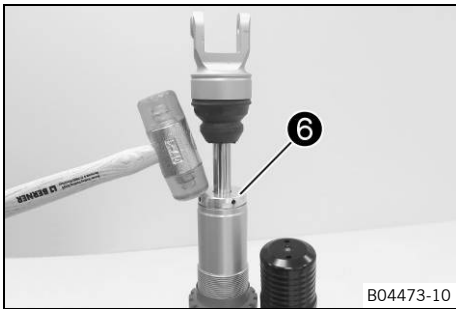

- Mount locking cap ⑥ of the damper cartridge.
- Bleed and fill the damper. (📖 p. 96)
- Fill the damper with nitrogen. (📖 p. 99)

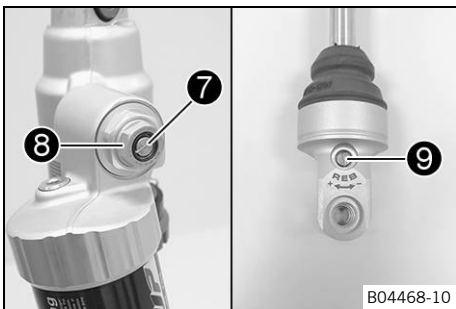

Alternative 1

- Turn adjusting screw ⑦ clockwise with a screwdriver up to the last perceptible click.
- Turn counterclockwise by the number of clicks corresponding to the shock absorber type.

Guideline

Compression damping, low-speed	
Comfort	18 clicks
Standard	15 clicks
Sport	12 clicks

- Using an open end wrench, turn adjusting screw ⑧ clockwise all the way.
- Turn counterclockwise by the number of turns corresponding to the shock absorber type.

Guideline

Compression damping, high-speed	
Comfort	2.5 turns
Standard	2 turns
Sport	1 turn

- Turn adjusting screw ⑨ clockwise up to the last perceptible click.

- Turn counterclockwise by the number of clicks corresponding to the shock absorber type.

Guideline

Rebound damping	
Comfort	18 clicks
Standard	15 clicks
Sport	12 clicks

Alternative 2



Warning

Danger of accident Modifications to the suspension setting may seriously alter the handling characteristic.

Extreme modifications to the suspension setting may cause a serious deterioration in the handling characteristic and overload components.

- Only make adjustments within the recommended range.
- Ride slowly to start with after making adjustments to get the feel of the new handling characteristic.

- Position adjusting screws ⑦, ⑧, and ⑨ in the location determined during disassembly.

9.23 Bleeding and filling the damper



Info

Before working with the vacuum pump, carefully read the operating manual included with the vacuum pump.
Open the adjusters of the rebound and compression damping completely.

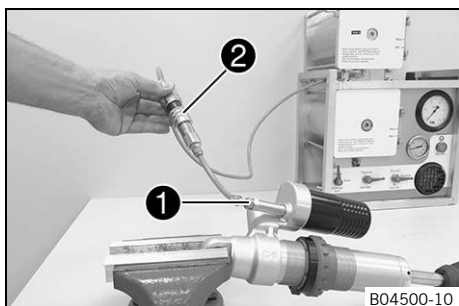

- Clamp the damper as shown.

Guideline

Use soft jaws.



Info

The filling port must be located at the highest position. The piston rod moves in and out during filling; do not immobilize it by holding it with your hand.

- Remove the filling port screw with the O-ring.
- Mount adapter ① on the damper.



Info

Hand-tighten only without using a tool.

- Connect adapter ① to connector ② of the vacuum pump.

Vacuum pump (T1240S) (📖 p. 373)

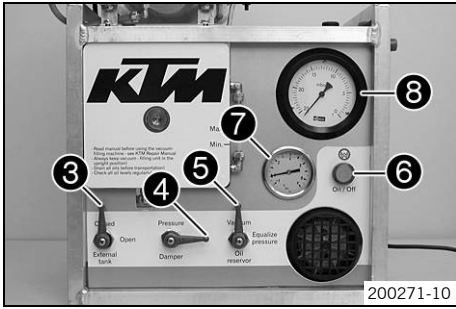

- Adjust the control lever as shown.
 - ✓ Control lever **External tank** ③ is set to **Closed**, **Damper** ④ is set to **Vacuum** and **Oil reservoir** ⑤ is set to **Vacuum**.

- Activate **On/Off** switch ⑥.

- ✓ The suction process begins.

- ✓ Pressure gauge ⑦ drops to the required value.

< 0 bar

- ✓ Vacuum gauge ⑧ drops to the required value.

4 mbar

- Determine distance **A** between the floating piston and reservoir hole with the special tool.

Depth micrometer (T107S) (📖 p. 372)

- ✓ The floating piston is located in the lowermost position.

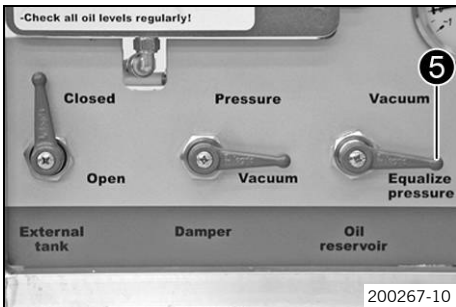
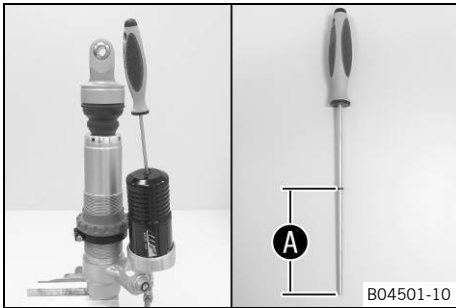

- When the vacuum gauge reaches the required value, turn control lever **Oil reservoir** ⑤ to **Equalize pressure**.

Guideline

4 mbar

- ✓ The pressure gauge increases to the required value.

0 bar

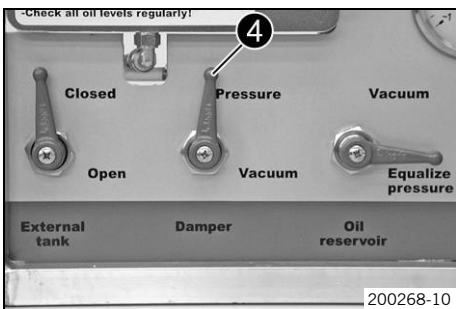

- When the pressure gauge reaches the specified value, turn control lever **Damper** ④ to **Pressure**.

Guideline

0 bar

- ✓ Oil is pumped into the damper.

- ✓ The pressure gauge increases to the required value.

3 bar

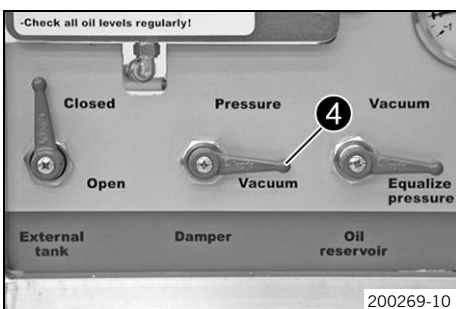

- When the pressure gauge reaches the specified value, turn control lever **Damper** ④ to **Vacuum**.

Guideline

3 bar

- ✓ The pressure gauge drops to the required value.

0 bar

9 SHOCK ABSORBER, SWINGARM

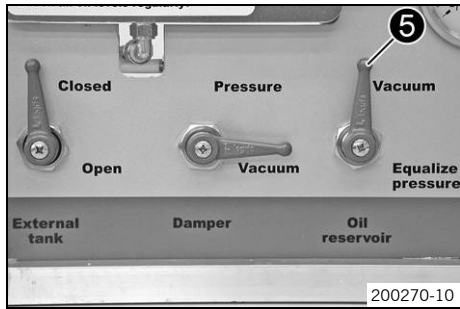

- When the pressure gauge reaches the specified value, turn control lever **Oil reservoir 5** to **Vacuum**.

Guideline

0 bar

- ✓ The vacuum gauge drops to the required value.

8 mbar

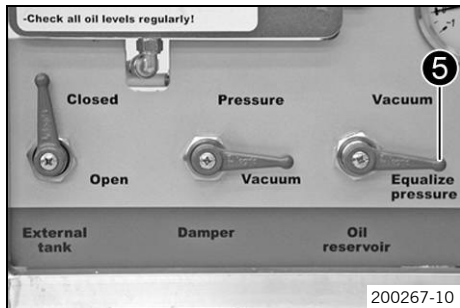

- When the vacuum gauge reaches the required value, turn control lever **Oil reservoir 5** to **Equalize Pressure**.

Guideline

8 mbar

- ✓ The pressure gauge drops to the required value.

0 bar

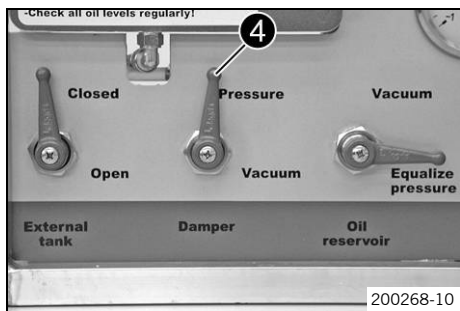

- When the pressure gauge reaches the specified value, turn control lever **Damper 4** to **Pressure**.

Guideline

0 bar

- ✓ Oil is pumped into the damper.
- ✓ The pressure gauge increases to the required value.

3 bar

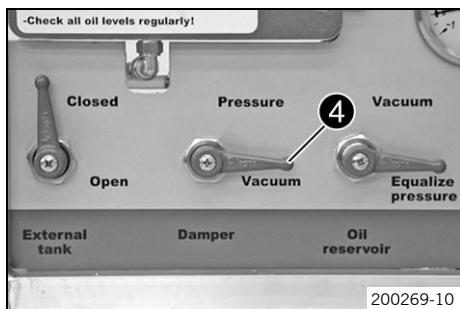

- When the pressure gauge reaches the specified value, turn control lever **Damper 4** to **Vacuum**.

Guideline

3 bar

- ✓ The pressure gauge drops to the required value.

0 bar

- When the pressure gauge reaches the required value, activate the **On/Off** switch.

Guideline

0 bar

- ✓ The vacuum pump is switched off.

- Slide O-ring **B** to the end of the special tool by the specified value (distance **A** minus specified value).

Guideline

5 mm

Depth micrometer (T107S) (📖 p. 372)

- Slide the floating piston into the reservoir to the shortened position using the special tool.

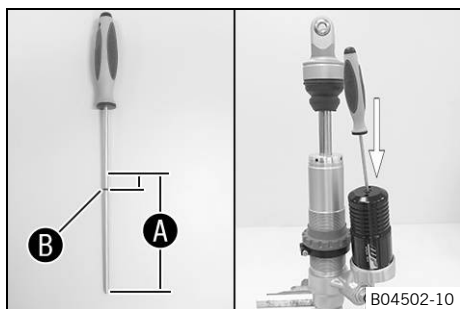

i Info
The floating piston must be positioned at exactly this point when the rod is fully extended; otherwise, damage will occur during compression of the shock absorber.

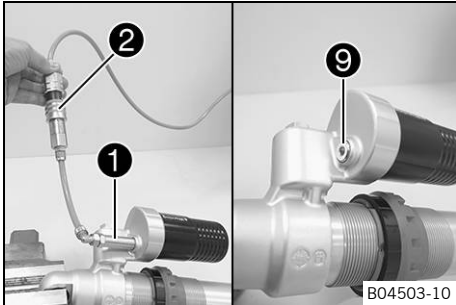

- Remove the special tool.
- Remove adapter ① from connector ② of the vacuum pump.

i Info
Hold the damper so that the filling port is at the highest point.

- Remove the adapter.
- Mount screw ⑨ with the O-ring and tighten.

Guideline

Filling port screw	M10x1	14 Nm (10.3 lbf ft)
--------------------	-------	---------------------

9.24 Filling damper with nitrogen

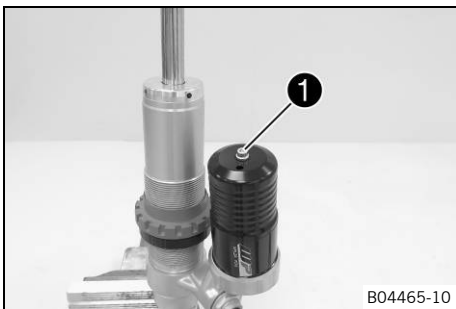

- Mount screw ① with the O-ring and screw it in approx. 2 full turns, but do not tighten it fully yet.

i Info
The piston rod is fully extended.

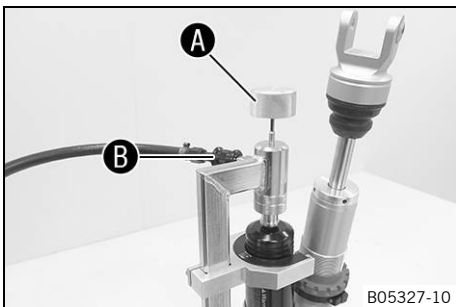

- Fix the special tool in the vise.

Filling tool (T170S1) (📖 p. 376)

Filling adapter (T1565) (📖 p. 376)

- Connect the special tool to the pressure regulator of the filling cylinder.

Filling gas - nitrogen

- Adjust the pressure regulator.

Guideline

Gas pressure	10 bar (145 psi)
--------------	------------------

- Position the damper in the special tool.
 - ✓ The hexagonal part of tap handle **A** engages in the hexagon socket of the filling port screw.

- Open filler tap **B**.
- Fill the damper for at least 15 seconds.

Guideline

Gas pressure	10 bar (145 psi)
--------------	------------------

i Info

Watch the pressure regulator dial.
Ensure that the damper is filled to the specified pressure.

- Screw the filling port shut with tap handle **A**.
- Close spigot **B** and take the damper out of the special tool.
- Tighten the filling port screw.

Guideline

Screw, filling port, reservoir	M5	3 Nm (2.2 lbf ft)
--------------------------------	----	-------------------

9.25 Installing the spring

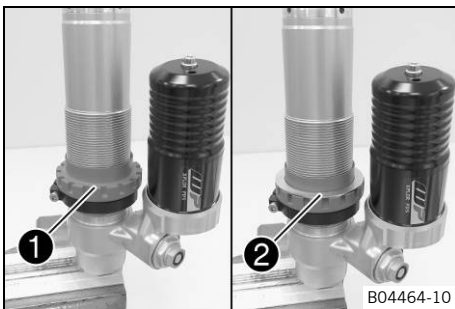

- Clamp the shock absorber into the vise.

Guideline

Use soft jaws.

- Ensure that adjusting ring **1** is mounted with the clamping ring.
- Mount washer **2**.

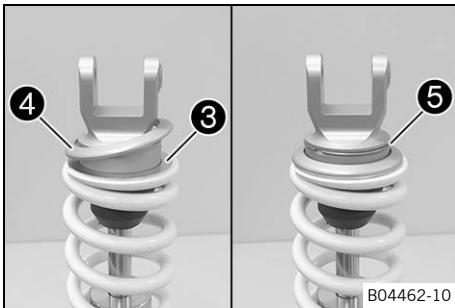

- Measure the total spring length while the spring is not under tension.

- Position the spring.

Guideline

Spring rate	
Weight of rider: 65 ... 75 kg (143 ... 165 lb.)	57 ... 63 N/mm (325 ... 360 lb/in)
Weight of rider: 75 ... 85 kg (165 ... 187 lb.)	60 ... 66 N/mm (343 ... 377 lb/in)
Weight of rider: 85 ... 95 kg (187 ... 209 lb.)	63 ... 69 N/mm (360 ... 394 lb/in)

- Mount washer **3**.
- Mount spring retainer **4**.
- Mount lock ring **5**.

Alternative 1

- Tension the spring by turning the adjusting ring to the prescribed value.

Guideline

Spring preload	8 mm (0.31 in)
----------------	----------------

Holding wrench (90129051000) (🔧 p. 371)

Alternative 2



Warning

Danger of accident Modifications to the suspension setting may seriously alter the handling characteristic.

Extreme modifications to the suspension setting may cause a serious deterioration in the handling characteristic and overload components.

- Only make adjustments within the recommended range.
- Ride slowly to start with after making adjustments to get the feel of the new handling characteristic.

- Tension the spring to the length measured during disassembly by turning the adjusting ring.

Holding wrench (90129051000) (📖 p. 371)

- Tighten screw **6**.

Guideline

Screw, shock absorber adjusting ring	M5	5 Nm (3.7 lbf ft)
--------------------------------------	----	-------------------

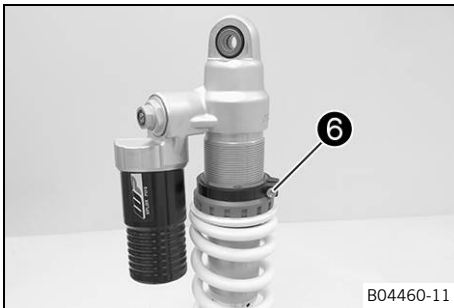

9.26 Checking the swingarm



- Check the swingarm for damage, cracking, and deformation.
 - » If the swingarm shows signs of damage, cracking, or deformation:
 - Change the swingarm.



Info

Always change a damaged swingarm. Repair of the swingarm is not authorized by KTM.

9.27 Checking the heim joint for play

Preparatory work

- Raise the motorcycle with a lift stand. (📖 p. 12)
- Place a load on the front of the vehicle.
 - ✓ The rear wheel is not in contact with the ground.

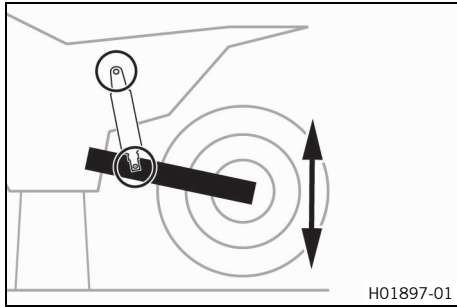

Main work

- Check the top and bottom heim joints.
- Move the swingarm up and down.
 - » If there is detectable play:
 - Change the heim joint. (📖 p. 102)

Finishing work

- Remove load from the front of the vehicle.
- Remove the motorcycle from the lift stand. (📖 p. 12)

9.28 Changing the heim joint

Preparatory work

- Raise the motorcycle with a lift stand. (📖 p. 12)
- Remove the shock absorber. (📖 p. 83)

Main work

- Clamp the shock absorber into the vise.

Guideline

Use soft jaws.

- Remove both collar bushings ① of the heim joint with a special tool.

Drift (T120) (📖 p. 372)

- Press the heim joint against a lock ring using the special tool.

Pressing tool (T1207S) (📖 p. 373)

- Remove second lock ring ②.

- Place special tool A underneath and press out heim joint ③ using special tool B.

Pressing tool (T1207S) (📖 p. 373)

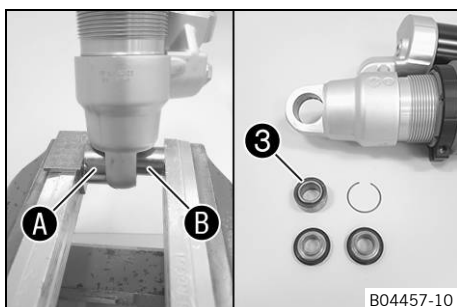
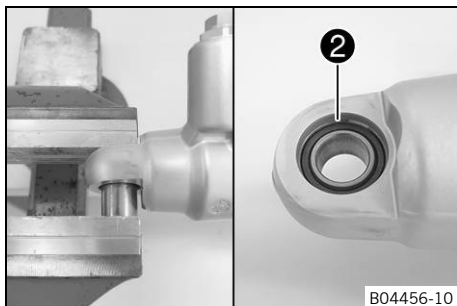
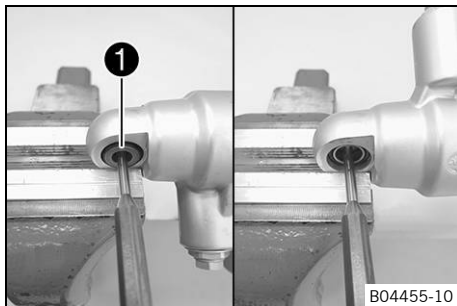

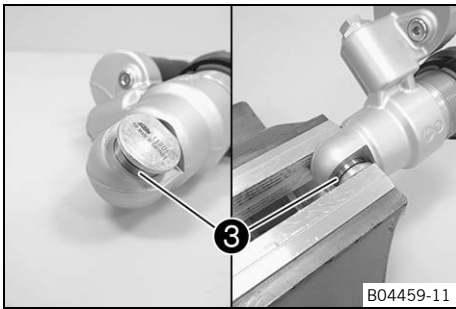

- Position the new heim joint **3** and the special tool.

Guideline

Use soft jaws.

Pressing tool (T1206) (📖 p. 373)

- Press the heim joint all the way in.

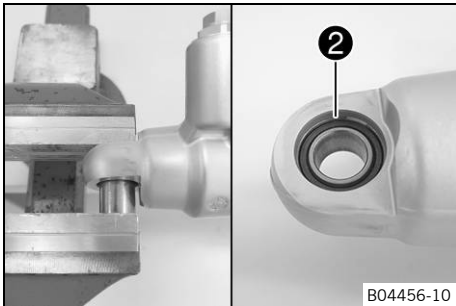

- Press the heim joint against the lock ring using the special tool.

Pressing tool (T1207S) (📖 p. 373)

- Mount second lock ring **2**.

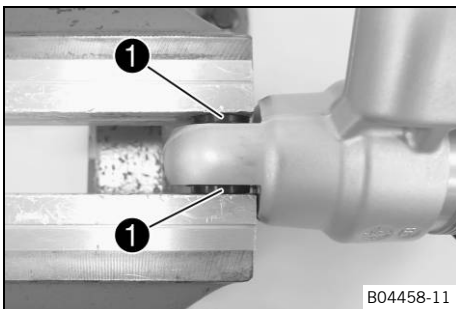

- Position both collar bushings **1** and press in.

Finishing work

- Install the shock absorber. (📖 p. 83)
- Remove the motorcycle from the lift stand. (📖 p. 12)

9.29 Changing the heim joint on the swingarm

Preparatory work

- Raise the motorcycle with a lift stand. (📖 p. 12)

Main work

- Remove screw **1** and lower the rear wheel with the swingarm as far as possible without blocking the rear wheel. Secure the rear wheel in this position.

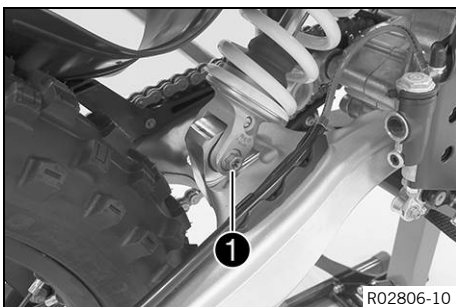

Info

Raise the wheel slightly to make it easier to remove the screw.

- Swing the shock absorber to the rear.

9 SHOCK ABSORBER, SWINGARM

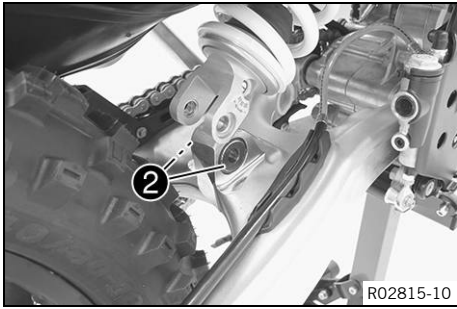

R02815-10

- Remove spacers **2** on both sides.

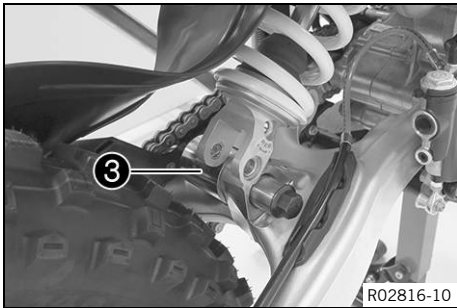

R02816-10

- Mount special tool **3**.

Pressing tool (79629000044) (📖 p. 371)

- Press out the heim joint by screwing in the screw.

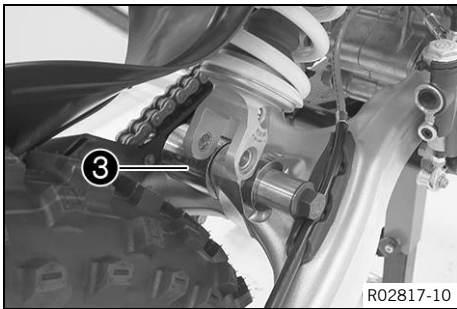

R02817-10

- Position the new heim joint.

- Mount special tool **3**.

Pressing tool (79629000044) (📖 p. 371)

- Press in the heim joint by screwing in the screw.

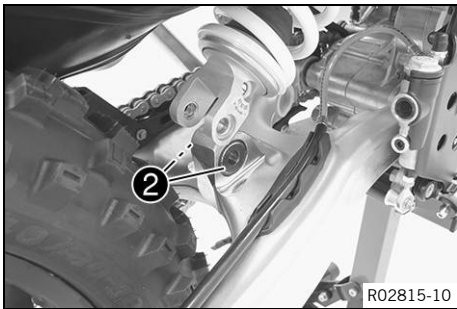

R02815-10

- Mount spacers **2** on both sides.

i Info

The heim joint for the shock absorber at the swingarm is Teflon-coated. It must not be greased with grease or with other lubricants. Lubricants dissolve the Teflon coating, thereby drastically reducing the service life.

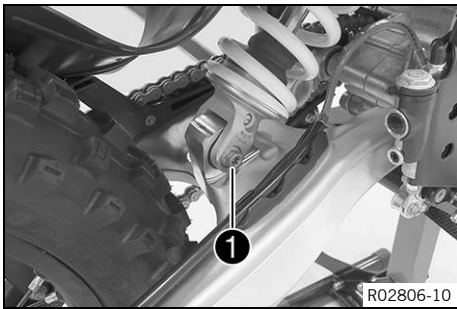

R02806-10

- Position the shock absorber.

- Mount and tighten screw **1**.

Guideline

Screw, bottom shock absorber	M12	80 Nm (59 lbf ft) Loctite®2701™
------------------------------	-----	---

i Info

Raise the wheel slightly to be able to mount the screw more easily.

Finishing work

- Remove the motorcycle from the lift stand. (📖 p. 12)

9.30 Checking the swingarm bearing for play

Preparatory work

- Raise the motorcycle with a lift stand. (📖 p. 12)
- Place a load on the front of the vehicle.
- ✓ The rear wheel is not in contact with the ground.

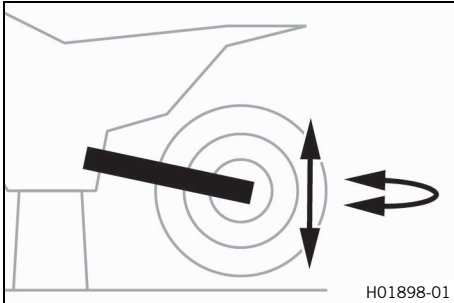

Main work

- Move the swingarm up and down.
 - » If there is detectable play:
 - Change the swingarm bearing. (📖 p. 108)
- Move the swingarm from one side to the other.
 - » If there is detectable play:
 - Change the swingarm bearing. (📖 p. 108)

Finishing work

- Remove the motorcycle from the lift stand. (📖 p. 12)

9.31 Removing the swingarm

Preparatory work

- Raise the motorcycle with a lift stand. (📖 p. 12)
- Remove the rear wheel. (📖 p. 144)

Main work

- Remove screws ① with the washers.
- Remove the cable ties.
- Take off the frame protector on both sides.

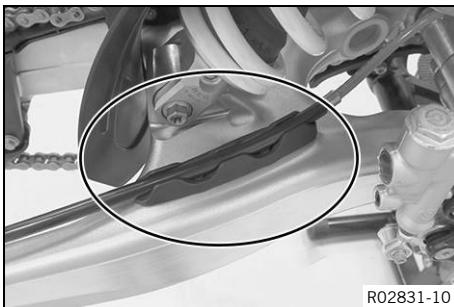
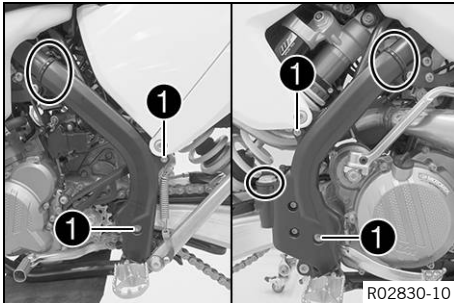

- Take the brake line out of the guide.

9 SHOCK ABSORBER, SWINGARM

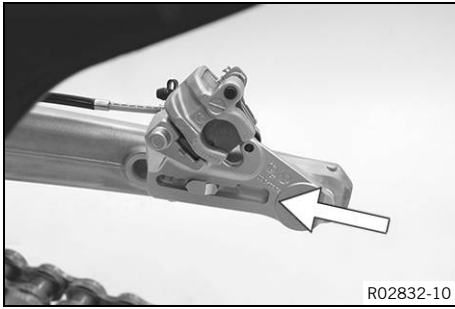

- Push the brake caliper forward, slip it out, and hang it to the side.



Info

Cover the components to protect them against damage.

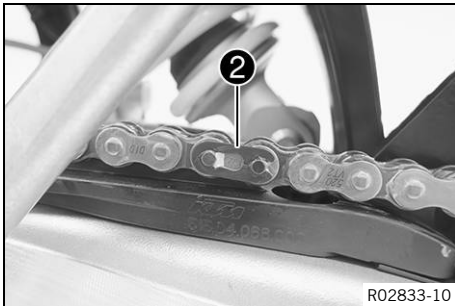

- Remove connecting link ② of the chain.



Info

Cover the components to protect them against damage.

- Take off the chain.

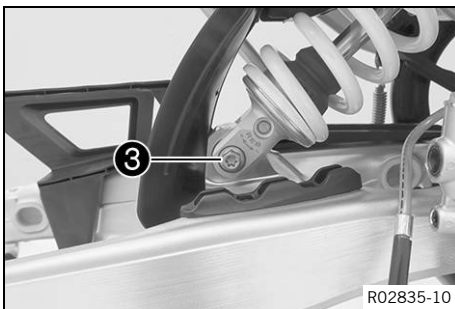

- Remove screw ③.
- Push the swingarm down and away from the shock absorber.

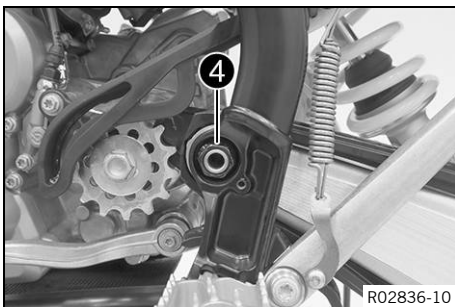

- Remove nut ④.
- Remove the swingarm pivot.
- Take off the swingarm.

9.32 Installing the swingarm

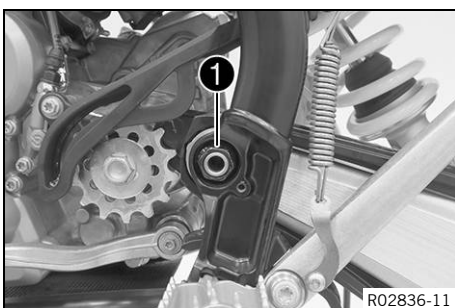

Main work

- Position the swingarm. Mount the swingarm pivot.
- Mount and tighten nut ①.

Guideline

Nut, swingarm pivot	M16x1.5	100 Nm (73.8 lbf ft)
---------------------	---------	-------------------------

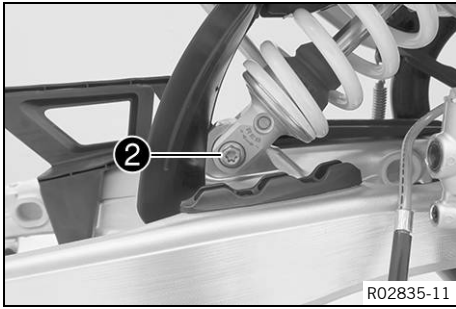

- Lift the swingarm and position the shock absorber.
- Mount and tighten screw ②.

Guideline

Screw, bottom shock absorber	M12	80 Nm (59 lbf ft) Loctite®2701™
------------------------------	-----	---

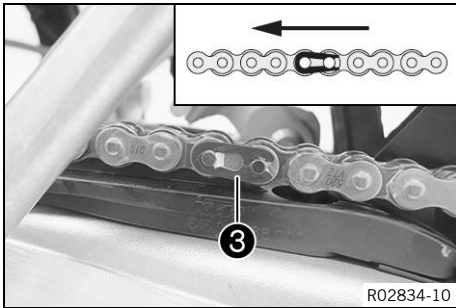

- Mount the chain.
- Connect the chain with connecting link ③.

Guideline

The closed side of the chain joint lock must face in the direction of travel.

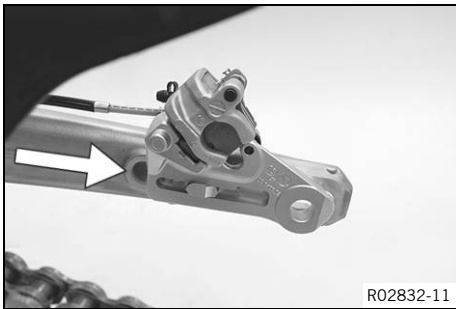

- Position the brake caliper.

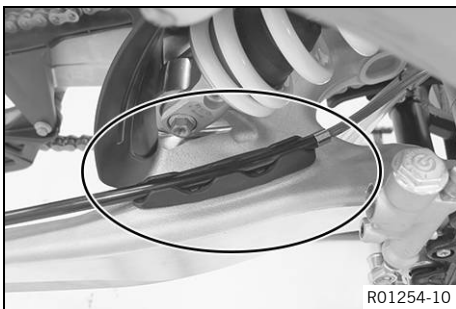

- Position the brake line in the guide.

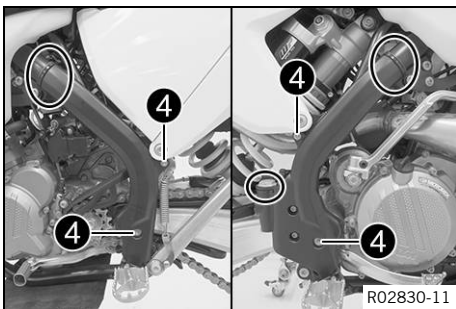

- Position the frame protectors on the left and right.
- Mount and tighten screws ④ with the washers.

Guideline

Screw, frame protector	M5	3 Nm (2.2 lbf ft)
------------------------	----	-------------------

- Mount the cable ties.

Finishing work

- Install the rear wheel. (📖 p. 145)
- Check the chain tension. (📖 p. 150)
- Remove the motorcycle from the lift stand. (📖 p. 12)

9.33 Changing the swingarm bearing

Preparatory work

- Raise the motorcycle with a lift stand. (📖 p. 12)
- Remove the rear wheel. (📖 p. 144)
- Remove the swingarm. (📖 p. 105)

Left swingarm bearing

- Remove collar bushings **1**.

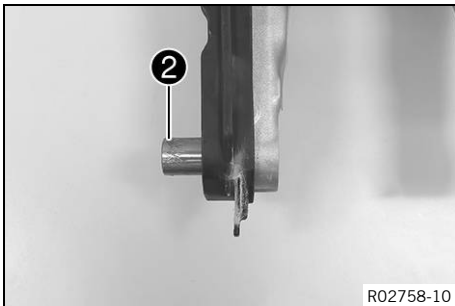
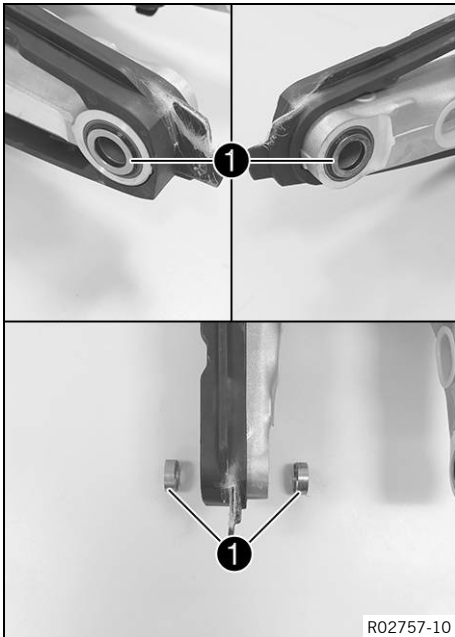

- Remove bushing **2**.

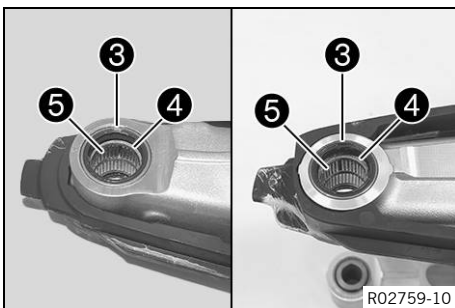

- Remove shaft seal rings **3** using a suitable tool.
- Remove stop disks **4**.
- Press out bearing **5** using a suitable tool.
- Using a suitable tool, press in new bearing **5**.
- Position the stop disks **4**.
- Press in shaft seal rings **3**.

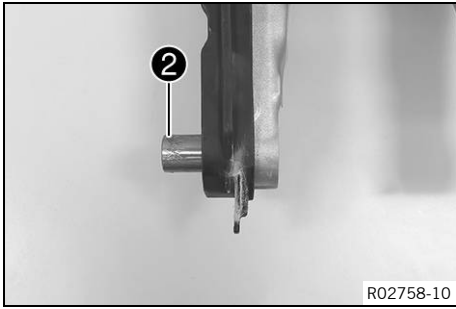

- Mount bushing ②.

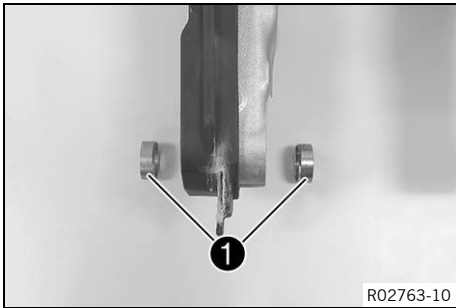

- Grease the shaft seal rings.
Long-life grease (🔧 p. 360)
- Position the collar bushings ① with the shoulder facing inward.

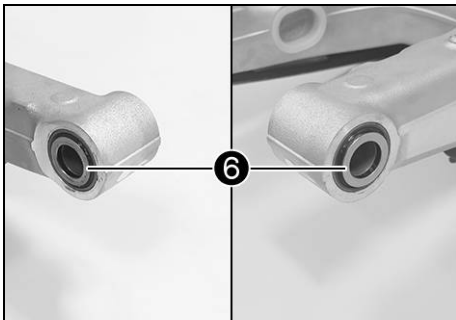

Right swingarm bearing

- Remove collar bushings ⑥.

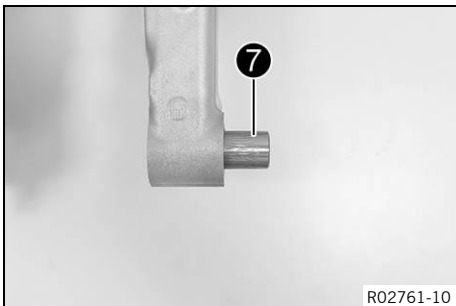
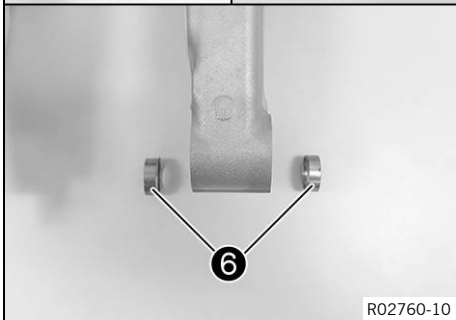

- Remove bushing ⑦.

9 SHOCK ABSORBER, SWINGARM

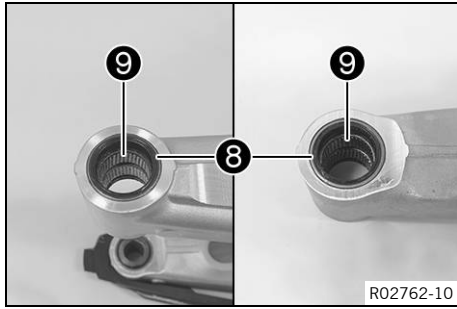

- Remove shaft seal rings 8 using a suitable tool.
- Press out bearing 9 using a suitable tool.
- Using a suitable tool, press in new bearing 9.
- Press in shaft seal rings 8.

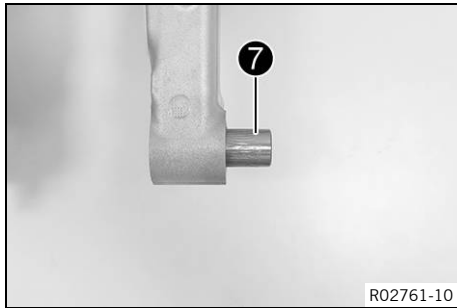

- Mount bushing 7.

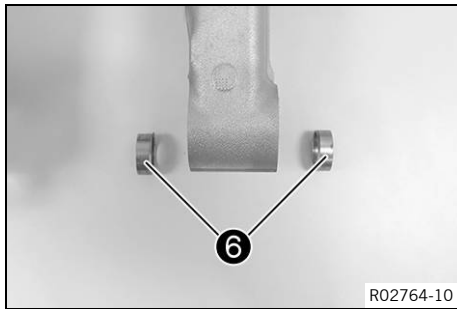

- Grease the shaft seal rings.

Long-life grease (📖 p. 360)

- Position the collar bushings 6 with the shoulder facing inward.

Finishing work

- Install the swingarm. (📖 p. 106)
- Install the rear wheel. (📖 p. 145)
- Check the chain tension. (📖 p. 150)
- Remove the motorcycle from the lift stand. (📖 p. 12)

10.1 Removing the manifold

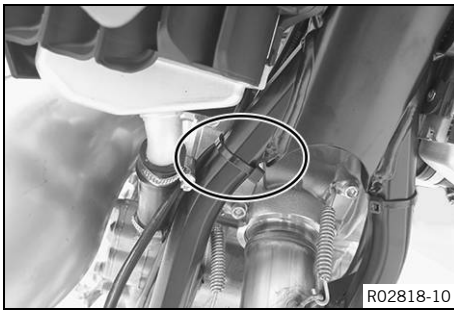

(All EXC models)

- Remove the cable tie(s) and expose the cable.

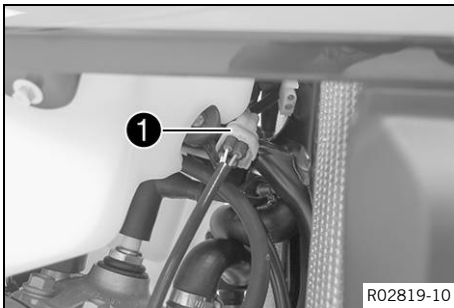

- Disconnect plug-in connector **1** of the lambda sensor.
- Expose the cable.

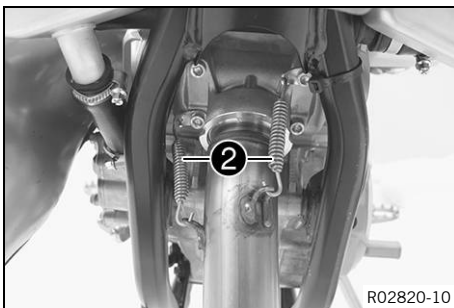

- Remove springs **2**.

Spring hook (5030501700004) (📖 p. 371)

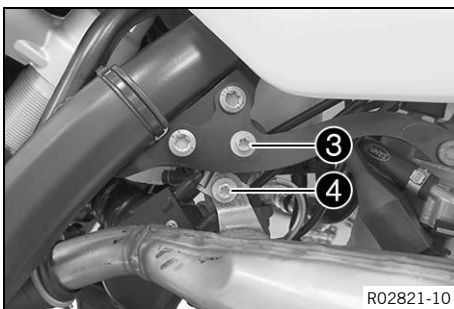

- Loosen screw **3**.
- Remove screw **4**.
- Take off the exhaust manifold toward the front.

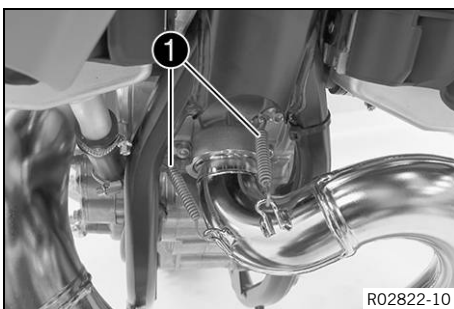

(All XC-W models)

- Remove springs **1**.

Spring hook (5030501700004) (📖 p. 371)

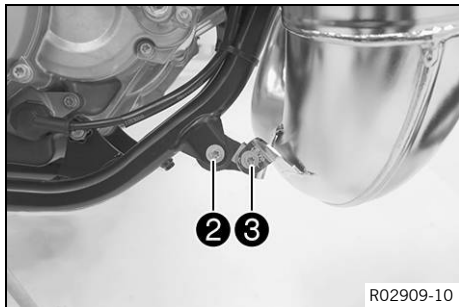

- Loosen screw ②.
- Remove screw ③.

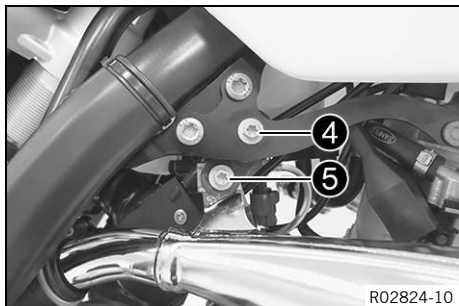

- Loosen screw ④.
- Remove screw ⑤.
- Take off the exhaust manifold toward the front.

10.2 Installing the manifold

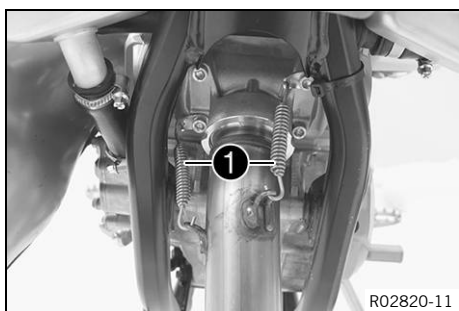

(All EXC models)

- Position the manifold and mount springs ①.

Spring hook (5030501700004) (📖 p. 371)

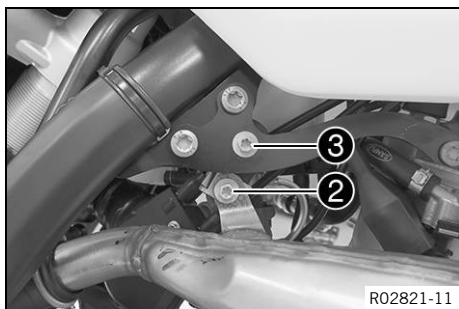

- Mount and tighten screw ②.

Guideline

Remaining screws, chassis	M6	10 Nm (7.4 lbf ft)
---------------------------	----	--------------------

- Tighten screw ③.

Guideline

Remaining screws, chassis	M6	10 Nm (7.4 lbf ft)
---------------------------	----	--------------------

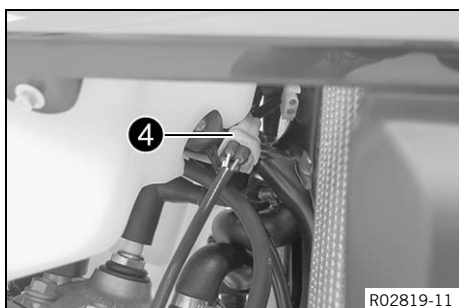

- Join plug-in connector ④ of the lambda sensor.

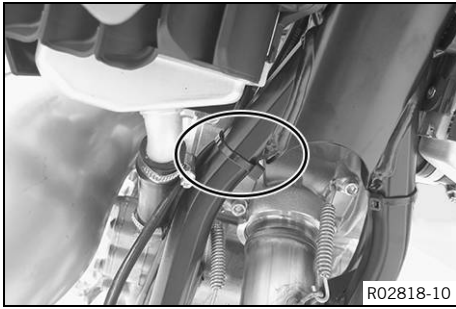

- Route the cable without tension and secure it with a cable tie.

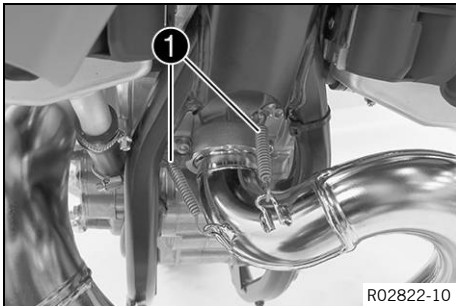

(All XC-W models)

- Position the manifold and mount springs **1**.

Spring hook (5030501700004) (📖 p. 371)
--

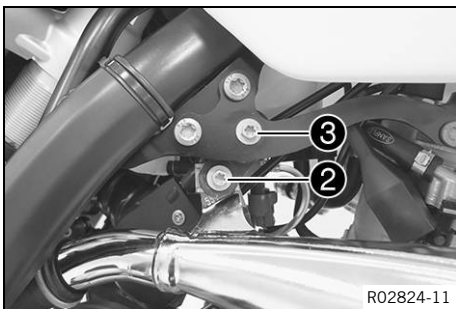

- Mount and tighten screw **2**.

Guideline

Remaining screws, chassis	M6	10 Nm (7.4 lbf ft)
---------------------------	----	--------------------

- Tighten screw **3**.

Guideline

Remaining screws, chassis	M6	10 Nm (7.4 lbf ft)
---------------------------	----	--------------------

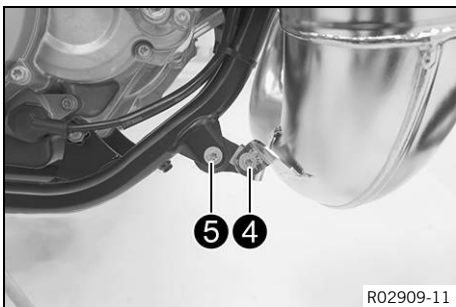

- Mount and tighten screw **4**.

Guideline

Remaining screws, chassis	M6	10 Nm (7.4 lbf ft)
---------------------------	----	--------------------

- Tighten screw **5**.

Guideline

Remaining screws, chassis	M6	10 Nm (7.4 lbf ft)
---------------------------	----	--------------------

10.3 Removing the main silencer



Warning

Danger of burns The exhaust system gets very hot when the vehicle is driven.

- Allow the exhaust system to cool down before performing any work on the vehicle.

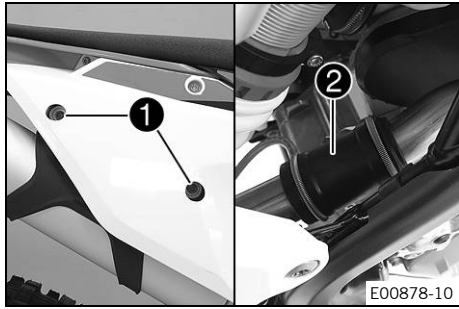

- Remove screws ①.
- Pull off the main silencer at the rubber sleeve ② and the spring ring from the manifold.

10.4 Installing the main silencer

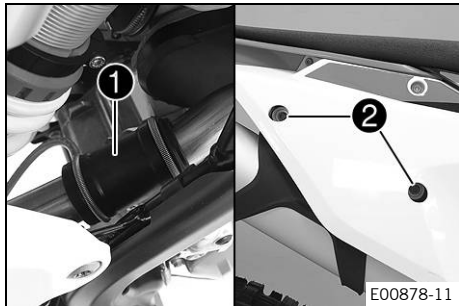

- Mount the main silencer with the rubber sleeve ① and spring ring.
- Mount and tighten screws ②.

Guideline

Remaining screws, chassis	M6	10 Nm (7.4 lbf ft)
---------------------------	----	--------------------

10.5 Changing the glass fiber yarn filling in the main silencer



Warning

Danger of burns The exhaust system gets very hot when the vehicle is driven.

- Allow the exhaust system to cool down before performing any work on the vehicle.



Info

Over time, the fibers of the glass fiber yarn escape and the damper "burns" out. Not only is the noise level higher, the performance characteristic changes.

Preparatory work

- Remove the main silencer. (📖 p. 113)

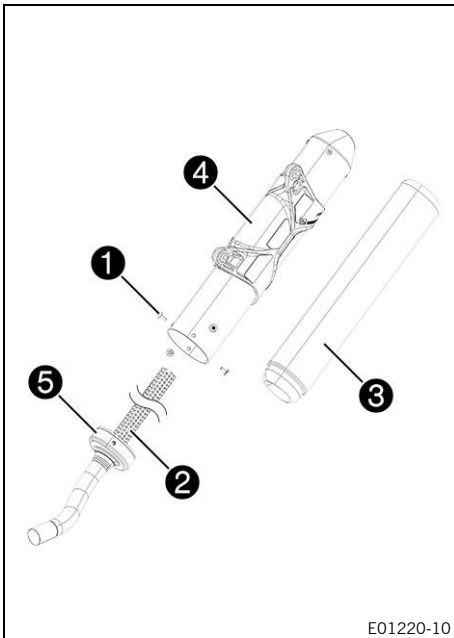

Main work

- Remove screws ①.
- Pull out inner tube ②.
- Remove the glass fiber yarn filling ③ from the inner tube.
- Clean the parts that need to be reinstalled and check for damage.
- Fit the new glass fiber yarn filling ③ into the inner tube.
- Position outer tube ④ over the inner tube with the new glass fiber yarn filling.



Info

Seal the connecting cap ⑤ to the outer tube with silicone.

- Mount and tighten screws ①.

Guideline

Screws on the main silencer	M5	7 Nm (5.2 lbf ft)
-----------------------------	----	-------------------

Finishing work

- Install the main silencer. (📖 p. 114)



11.1 Removing the air filter box cover

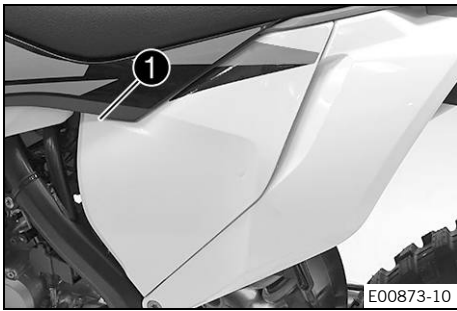

Condition

The air filter box cover is secured.

- Remove screw 1.

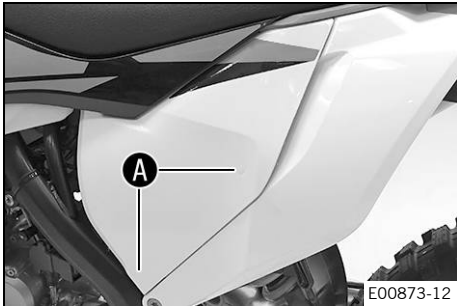

- Pull off the air filter box cover in area A sideways and take off toward the front.

11.2 Installing the air filter box cover

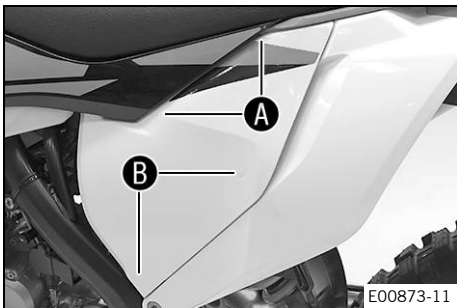

- Insert the air filter box cover in the area A and clip it into the area B.

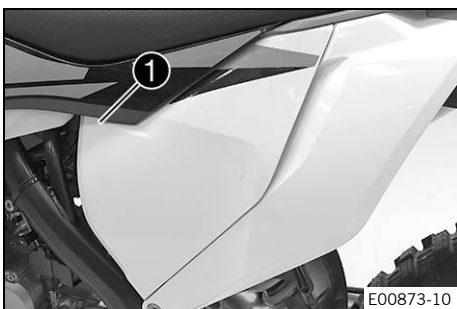

Condition

The air filter box cover is secured.

- Mount and tighten screw 1.

Guideline

Screw, air filter box cover	EJOT PT® K60x20-Z	3 Nm (2.2 lbf ft)
-----------------------------	-----------------------------	-------------------

11.3 Removing the air filter

Note

Engine damage Unfiltered intake air has a negative effect on the service life of the engine. Dust and dirt will enter the engine without an air filter.

- Never start to use the vehicle without an air filter.



Note

Environmental hazard Hazardous substances cause environmental damage.

- Dispose of oils, grease, filters, fuel, cleaning agents, brake fluid, etc., correctly and in compliance with the applicable regulations.



Preparatory work

- Remove the air filter box cover. (📖 p. 116)

Main work

- Detach retaining tab ①. Remove air filter with air filter support.
- Remove air filter from air filter support.

11.4 Installing the air filter

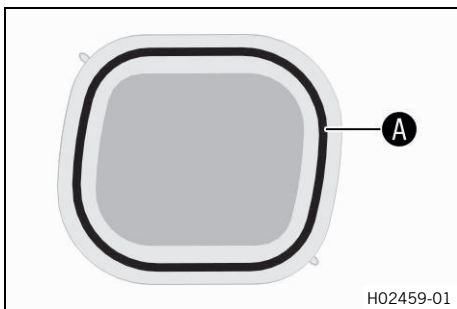

Main work

- Mount the clean air filter on the air filter support.
- Grease the air filter in area A.

Long-life grease (📖 p. 360)



- Insert air filter and position retaining pin ① in bushing B.
 - ✓ The air filter is correctly positioned.
- Insert retaining tab ②.
 - ✓ Retaining pin ③ is secured with retaining tab ②.



Info

If the air filter is not mounted correctly, dust and dirt may enter the engine and result in damage.

Finishing work

- Install the air filter box cover. (📖 p. 116)

11.5 Cleaning the air filter and air filter box



Note

Environmental hazard Hazardous substances cause environmental damage.

- Dispose of oils, grease, filters, fuel, cleaning agents, brake fluid, etc., correctly and in compliance with the applicable regulations.



Info

Do not clean the air filter with fuel or petroleum since these substances attack the foam.



Preparatory work

- Remove the air filter box cover. (📖 p. 116)
- Remove the air filter. (📖 p. 117)

Main work

- Wash the air filter thoroughly in special cleaning liquid and allow it to dry properly.

Air filter cleaner (📖 p. 360)



Info

Only squeeze the air filter to dry it; never wring it out.

- Oil the dry air filter with a high quality filter oil.

Oil for foam air filter (📖 p. 361)

- Clean the air filter box.
- Clean the intake flange and check it for damage and tightness.

Finishing work

- Install the air filter. (📖 p. 117)
- Install the air filter box cover. (📖 p. 116)

11.6 Preparing air filter box cover for securing

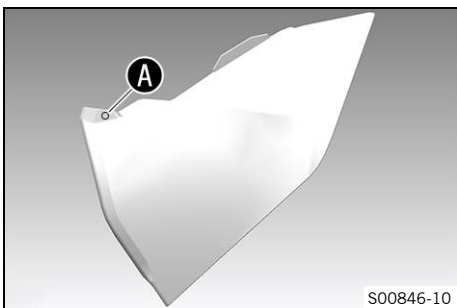

Preparatory work

- Remove the air filter box cover. (📖 p. 116)

Main work

- Drill a hole at marking **A**.

Guideline

Diameter	6 mm (0.24 in)
----------	----------------

Finishing work

- Install the air filter box cover. (📖 p. 116)

11.7 Sealing the air filter box

Preparatory work

- Remove the air filter box cover. (📖 p. 116)

Main work

- Seal the air filter box in the marked area **A**.

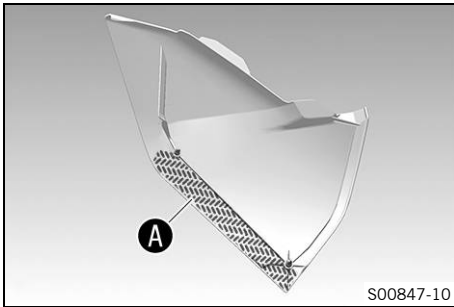

Finishing work

- Install the air filter box cover. (📖 p. 116)



12.1 Opening the filler cap



Danger

Fire hazard Fuel is highly flammable.

The fuel in the fuel tank expands when warm and can escape if overfilled.

- Do not refuel the vehicle in the vicinity of open flames or lit cigarettes.
- Switch off the engine for refueling.
- Make sure that no fuel is spilled; particularly not on hot parts of the vehicle.
- If any fuel is spilled, wipe it off immediately.
- Observe the specifications for refueling.



Warning

Danger of poisoning Fuel is poisonous and a health hazard.

- Avoid skin, eye and clothing contact with fuel.
- Immediately consult a doctor if you swallow fuel.
- Do not inhale fuel vapors.
- In case of skin contact, rinse the affected area with plenty of water.
- Rinse the eyes thoroughly with water, and consult a doctor in case of fuel contact with the eyes.
- Change your clothing in case of fuel spills on them.
- Keep fuels correctly in a suitable canister, and out of the reach of children.



Note

Environmental hazard Improper handling of fuel is a danger to the environment.

- Do not allow fuel to enter the groundwater, the soil, or the sewage system.

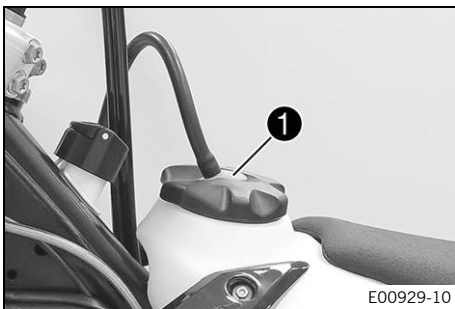

- Press release button **1**, turn the filler cap counterclockwise and lift it free.

12.2 Closing the filler cap

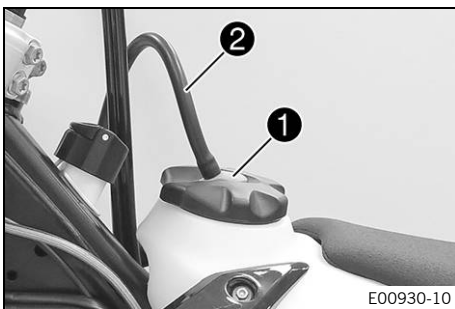

- Fit the filler cap and turn clockwise until release button **1** locks in place.



Info

Route fuel tank breather hose **2** without kinks.

12.3 Removing the seat

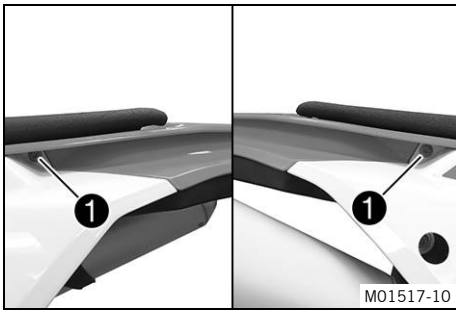

- Remove screws ①.

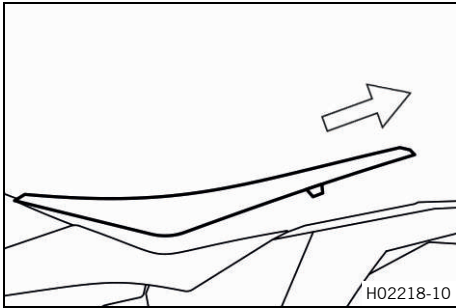

- Raise the rear of the seat, pull the seat back, and lift it off.

12.4 Mounting the seat

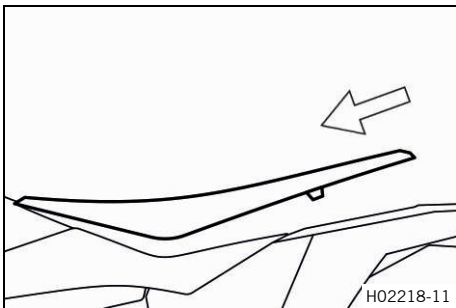

- Mount the front of the seat on the collar bushing of the fuel tank, lower the seat at the rear, and push the seat forward.
- Make sure that the seat is locked in correctly.

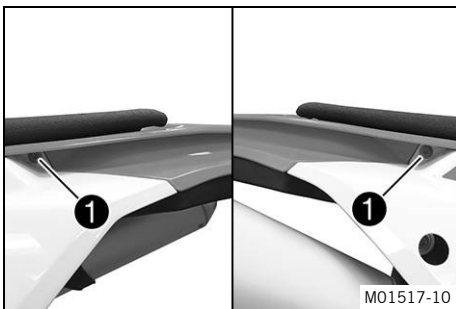

- Mount and tighten screws ①.

Guideline

Remaining screws, chassis	M6	10 Nm (7.4 lbf ft)
------------------------------	----	--------------------

12.5 Removing the fuel tank



Danger

Fire hazard Fuel is highly flammable.

The fuel in the fuel tank expands when warm and can escape if overfilled.

- Do not refuel the vehicle in the vicinity of open flames or lit cigarettes.
- Switch off the engine for refueling.
- Make sure that no fuel is spilled; particularly not on hot parts of the vehicle.
- If any fuel is spilled, wipe it off immediately.
- Observe the specifications for refueling.



Warning

Danger of poisoning Fuel is poisonous and a health hazard.

- Avoid skin, eye and clothing contact with fuel.
- Immediately consult a doctor if you swallow fuel.
- Do not inhale fuel vapors.
- In case of skin contact, rinse the affected area with plenty of water.
- Rinse the eyes thoroughly with water, and consult a doctor in case of fuel contact with the eyes.
- Change your clothing in case of fuel spills on them.
- Keep fuels correctly in a suitable canister, and out of the reach of children.

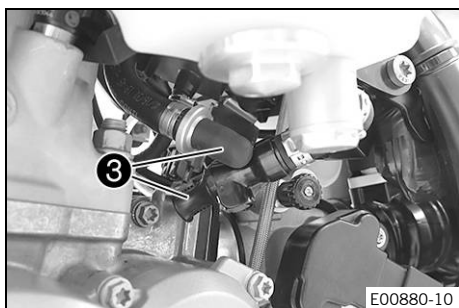
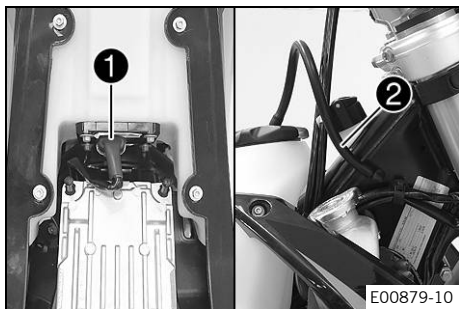

Preparatory work

- Remove the seat. (📖 p. 121)

Main work

- Unplug connector **1** of the fuel pump.
- Remove tube **2** from the fuel tank breather.

- Thoroughly clean the plug-in connection of the fuel line using compressed air.



Info

Under no circumstances should dirt enter into the fuel line. Dirt in the fuel line clogs the injection valve!

- Disconnect the plug-in connection of the fuel line.



Info

Remaining fuel may flow out of the fuel hose.

- Mount wash cap set **3**.

Wash cap set (81212016100)

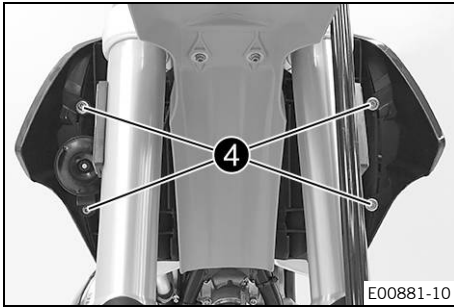

- Remove screws 4 with the collar bushings.
- (All EXC models)**
- Hang the horn and horn bracket to one side.

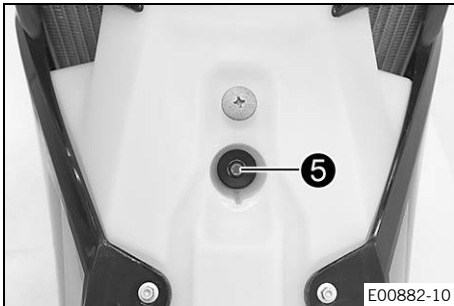

- Remove screw 5 with the rubber bushing.

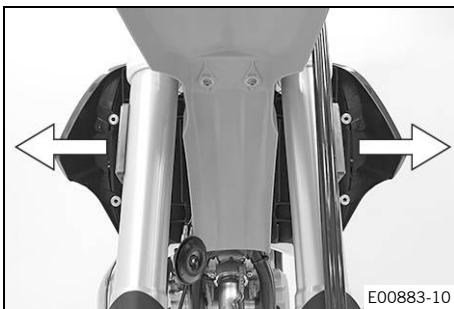

- Pull both spoilers off laterally from the radiator bracket and lift off the fuel tank.

12.6 Installing the fuel tank



Danger

Fire hazard Fuel is highly flammable.

The fuel in the fuel tank expands when warm and can escape if overfilled.

- Do not refuel the vehicle in the vicinity of open flames or lit cigarettes.
- Switch off the engine for refueling.
- Make sure that no fuel is spilled; particularly not on hot parts of the vehicle.
- If any fuel is spilled, wipe it off immediately.
- Observe the specifications for refueling.



Warning

Danger of poisoning Fuel is poisonous and a health hazard.

- Avoid skin, eye and clothing contact with fuel.
- Immediately consult a doctor if you swallow fuel.
- Do not inhale fuel vapors.
- In case of skin contact, rinse the affected area with plenty of water.
- Rinse the eyes thoroughly with water, and consult a doctor in case of fuel contact with the eyes.
- Change your clothing in case of fuel spills on them.

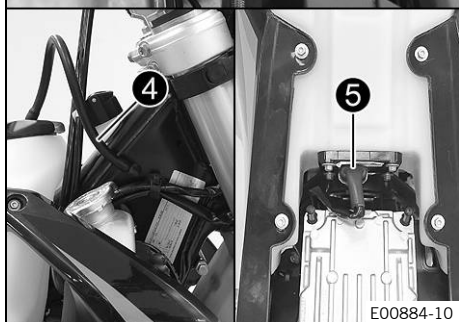
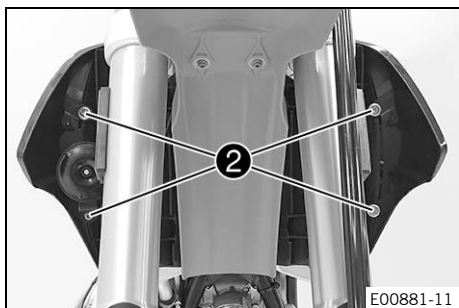
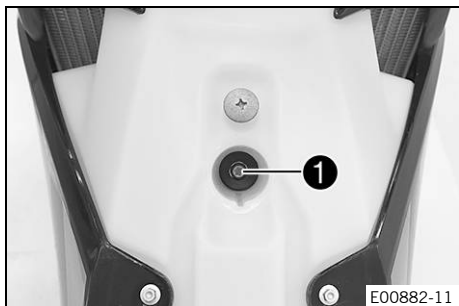
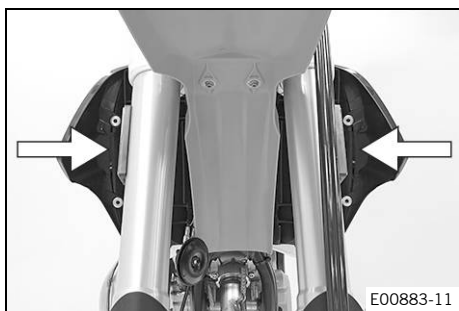

Main work

- Check throttle cable routing. (📖 p. 70)
- Position the fuel tank and fit the two spoilers to the sides in front of the radiator bracket.
- Make sure that no cables or throttle cables are trapped or damaged.

- Mount and tighten screw **1** with the rubber bushing.

Guideline

Remaining screws, chassis	M6	10 Nm (7.4 lbf ft)
---------------------------	----	--------------------

(All EXC models)

- Position the horn with the horn bracket.

- Mount and tighten screws **2** with the collar bushings.

Guideline

Remaining screws, chassis	M6	10 Nm (7.4 lbf ft)
---------------------------	----	--------------------

- Remove the wash cap set.
- Thoroughly clean the plug-in connection of the fuel line using compressed air.



Info

Under no circumstances should dirt enter into the fuel line. Dirt in the fuel line clogs the injection valve!

- Lubricate the O-ring and connect plug-in connection **3** for the fuel line.



Info

Route the cable and fuel line at a safe distance from the exhaust system.

- Attach fuel tank breather hose **4**.
- Plug in connector **5** for the fuel pump.

Finishing work

- Mount the seat. (📖 p. 121)



12.7 Changing the fuel screen



Danger

Fire hazard Fuel is highly flammable.

The fuel in the fuel tank expands when warm and can escape if overfilled.

- Do not refuel the vehicle in the vicinity of open flames or lit cigarettes.
- Switch off the engine for refueling.
- Make sure that no fuel is spilled; particularly not on hot parts of the vehicle.
- If any fuel is spilled, wipe it off immediately.
- Observe the specifications for refueling.



Warning

Danger of poisoning Fuel is poisonous and a health hazard.

- Avoid skin, eye and clothing contact with fuel.
- Immediately consult a doctor if you swallow fuel.
- Do not inhale fuel vapors.
- In case of skin contact, rinse the affected area with plenty of water.
- Rinse the eyes thoroughly with water, and consult a doctor in case of fuel contact with the eyes.
- Change your clothing in case of fuel spills on them.



Note

Environmental hazard Improper handling of fuel is a danger to the environment.

- Do not allow fuel to enter the groundwater, the soil, or the sewage system.

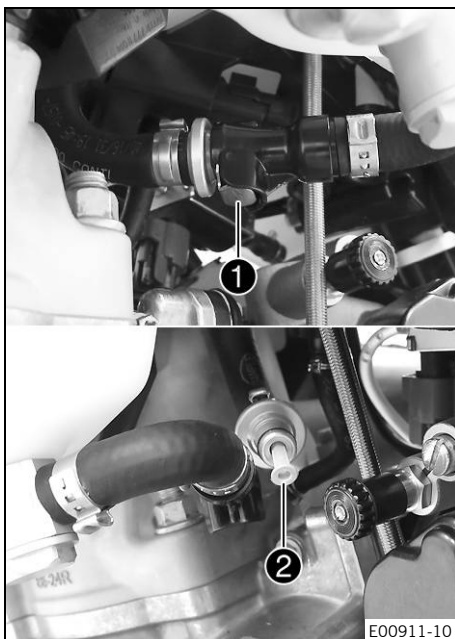

- Clean plug-in connection **1** of the fuel line thoroughly with compressed air.



Info

Under no circumstances should dirt enter into the fuel line. Dirt in the fuel line clogs the injection valve!

- Disconnect the plug-in connection of the fuel line.



Info

Remaining fuel may flow out of the fuel hose.

- Pull fuel screen **2** out of the connecting piece.
- Insert the new fuel screen all the way into the connecting piece.
- Lubricate the O-ring and join the plug-in connection of the fuel line.



Danger

Danger of poisoning Exhaust gases are toxic and inhaling them may result in unconsciousness and death.

- Always make sure there is sufficient ventilation when running the engine.
- Use an effective exhaust extraction system when starting or running the engine in an enclosed space.

- Start the engine and check the response.

12.8 Changing the fuel filter



Danger

Fire hazard Fuel is highly flammable.

The fuel in the fuel tank expands when warm and can escape if overfilled.

- Do not refuel the vehicle in the vicinity of open flames or lit cigarettes.
- Switch off the engine for refueling.
- Make sure that no fuel is spilled; particularly not on hot parts of the vehicle.
- If any fuel is spilled, wipe it off immediately.
- Observe the specifications for refueling.



Warning

Danger of poisoning Fuel is poisonous and a health hazard.

- Avoid skin, eye and clothing contact with fuel.
- Immediately consult a doctor if you swallow fuel.
- Do not inhale fuel vapors.
- In case of skin contact, rinse the affected area with plenty of water.
- Rinse the eyes thoroughly with water, and consult a doctor in case of fuel contact with the eyes.
- Change your clothing in case of fuel spills on them.
- Keep fuels correctly in a suitable canister, and out of the reach of children.



Note

Environmental hazard Improper handling of fuel is a danger to the environment.

- Do not allow fuel to enter the groundwater, the soil, or the sewage system.

Preparatory work

- Drain the fuel from the fuel tank into a suitable container.
- Remove the seat. (📖 p. 121)
- Remove the fuel tank. (📖 p. 122)

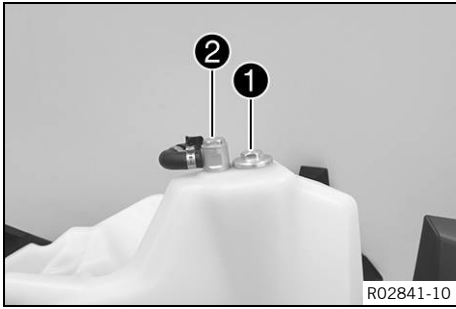

Main work

- Remove nut **1** with the gasket.
- Remove fuel connection **2** with the gasket.

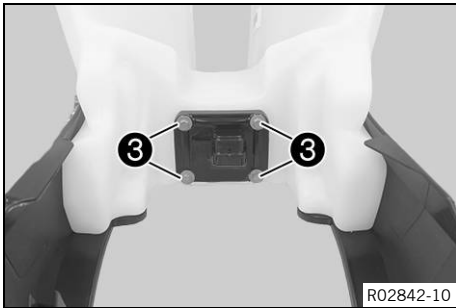

- Remove screws **3**.

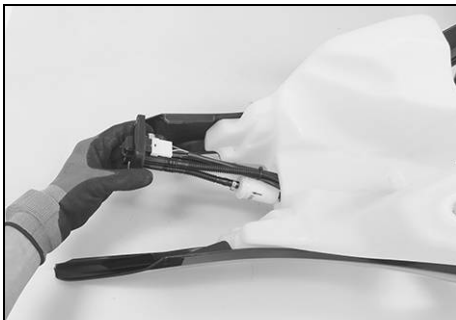

- Pull out the fuel pump.
- Remove hose clamps **4**.
- Remove fuel filter **5**.

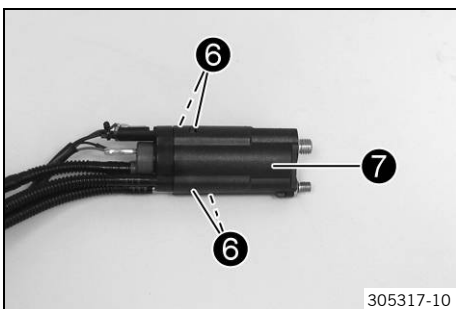
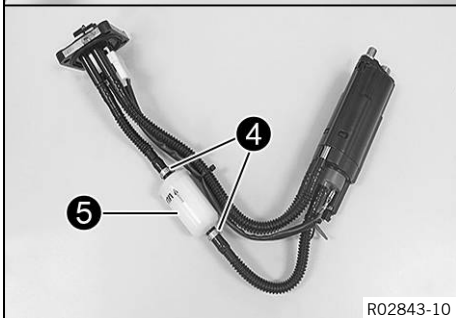

- Press locking mechanism **6**.
- Pull back fuel pump housing **7**.

12 FUEL TANK, SEAT, TRIM

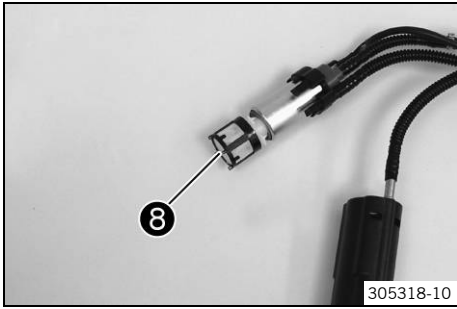

- Change fuel screen **8**.
- Mount the fuel pump housing.

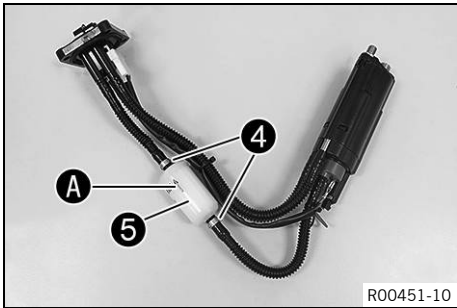

- Mount fuel filter **5**.
✓ Arrow **A** points away from the fuel pump.
- Mount hose clamps **4**.

Hose clamp plier (60029057000) (📖 p. 369)

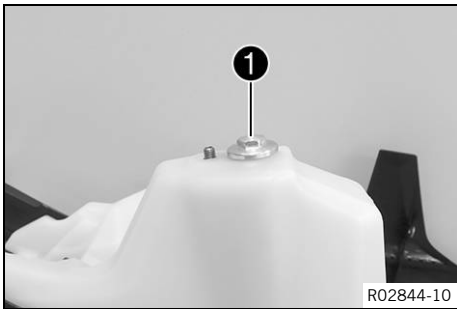

- Position the fuel pump.
- Mount nut **1** with gasket, but do not tighten yet.

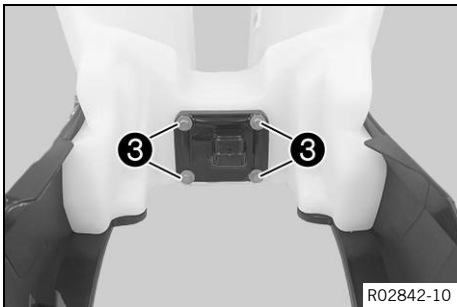

- Mount and tighten screws **3**.

Guideline

Screw, fuel pump	EJOT PT®	2.3 Nm (1.7 lbf ft)
------------------	----------	---------------------

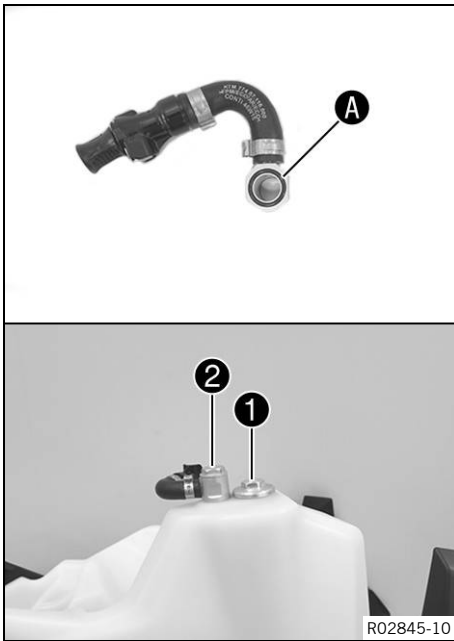

- Grease O-ring **A** slightly.

Multi-purpose grease (00062010051) (📖 p. 361)



Info

Make sure that no grease gets into the fuel connection.

- Mount fuel connection **2** with the gasket but do not tighten yet.
- Tighten nut **1**.

Guideline

Nut, fuel pump mounting	M12	15 Nm (11.1 lbf ft)
-------------------------	-----	---------------------

- Tighten fuel connection **2**.

Guideline

Fuel connection on fuel pump	M8	10 Nm (7.4 lbf ft)
------------------------------	----	--------------------

Finishing work

- Install the fuel tank. (📖 p. 123)
- Mount the seat. (📖 p. 121)

12.9 Changing the fuel pump



Danger

Fire hazard Fuel is highly flammable.

The fuel in the fuel tank expands when warm and can escape if overfilled.

- Do not refuel the vehicle in the vicinity of open flames or lit cigarettes.
- Switch off the engine for refueling.
- Make sure that no fuel is spilled; particularly not on hot parts of the vehicle.
- If any fuel is spilled, wipe it off immediately.
- Observe the specifications for refueling.



Warning

Danger of poisoning Fuel is poisonous and a health hazard.

- Avoid skin, eye and clothing contact with fuel.
- Immediately consult a doctor if you swallow fuel.
- Do not inhale fuel vapors.
- In case of skin contact, rinse the affected area with plenty of water.
- Rinse the eyes thoroughly with water, and consult a doctor in case of fuel contact with the eyes.
- Change your clothing in case of fuel spills on them.
- Keep fuels correctly in a suitable canister, and out of the reach of children.



Note

Environmental hazard Improper handling of fuel is a danger to the environment.

- Do not allow fuel to enter the groundwater, the soil, or the sewage system.

Preparatory work

- Drain the fuel from the fuel tank into a suitable container.
- Remove the seat. (📖 p. 121)
- Remove the fuel tank. (📖 p. 122)

Main work

- Remove nut ❶ with the gasket.
- Remove fuel connection ❷ with the gasket.

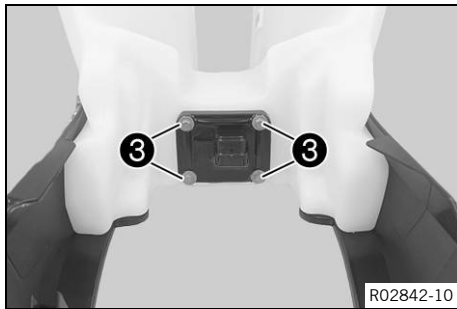
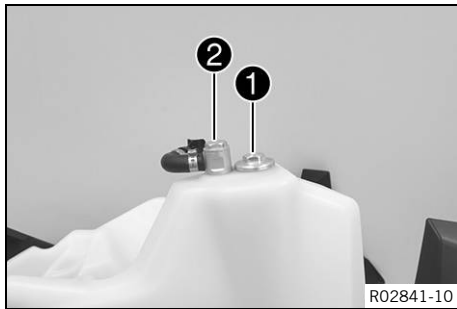

- Remove screws ❸.

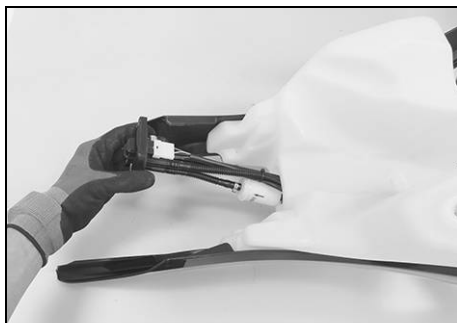

- Pull out the fuel pump.

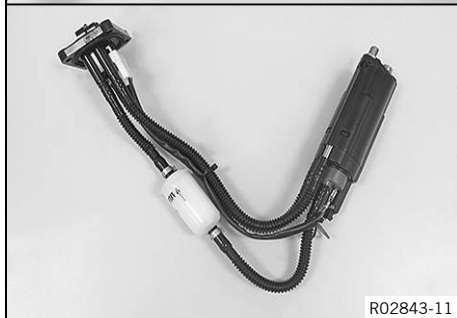

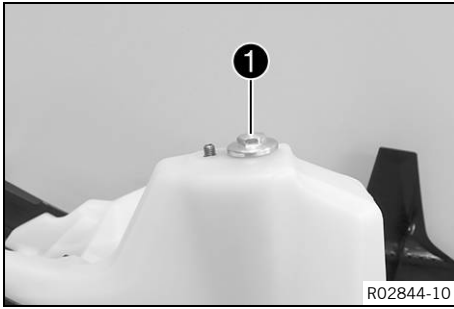

- Position the new fuel pump.
- Mount nut **1** with gasket, but do not tighten yet.

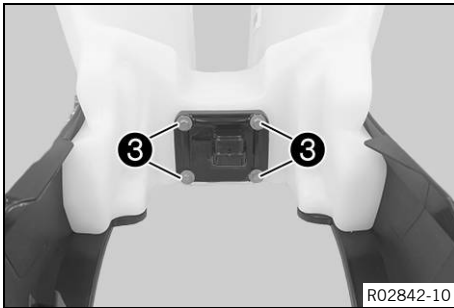

- Mount and tighten screws **3**.

Guideline

Screw, fuel pump	EJOT PT®	2.3 Nm (1.7 lbf ft)
------------------	-----------------	---------------------

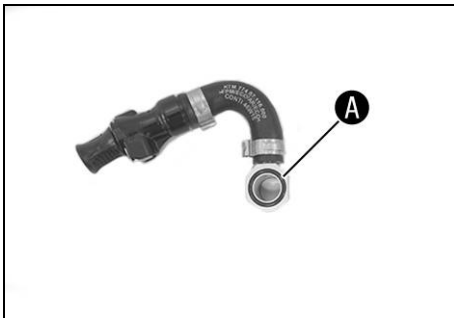

- Grease O-ring **A** slightly.

Multi-purpose grease (00062010051) (🗨️ p. 361)
--

i Info

Make sure that no grease gets into the fuel connection.

- Mount fuel connection **2** with the gasket but do not tighten yet.
- Tighten nut **1**.

Guideline

Nut, fuel pump mounting	M12	15 Nm (11.1 lbf ft)
-------------------------	-----	---------------------

- Tighten fuel connection **2**.

Guideline

Fuel connection on fuel pump	M8	10 Nm (7.4 lbf ft)
------------------------------	----	--------------------

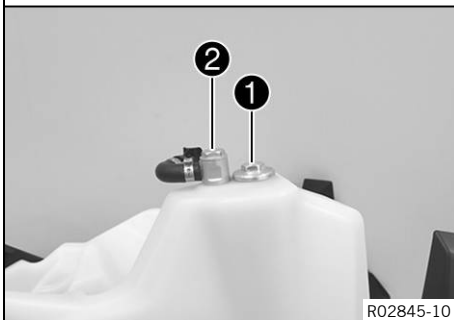

Finishing work

- Install the fuel tank. (🗨️ p. 123)
- Mount the seat. (🗨️ p. 121)



12.10 Checking the fuel pressure



Danger

Fire hazard Fuel is highly flammable.

The fuel in the fuel tank expands when warm and can escape if overfilled.

- Do not refuel the vehicle in the vicinity of open flames or lit cigarettes.
- Switch off the engine for refueling.
- Make sure that no fuel is spilled; particularly not on hot parts of the vehicle.
- If any fuel is spilled, wipe it off immediately.
- Observe the specifications for refueling.



Warning

Danger of poisoning Fuel is poisonous and a health hazard.

- Avoid skin, eye and clothing contact with fuel.
- Immediately consult a doctor if you swallow fuel.
- Do not inhale fuel vapors.
- In case of skin contact, rinse the affected area with plenty of water.
- Rinse the eyes thoroughly with water, and consult a doctor in case of fuel contact with the eyes.
- Change your clothing in case of fuel spills on them.
- Keep fuels correctly in a suitable canister, and out of the reach of children.

Condition

The fuel tank is completely full.

Ensure that the battery voltage does not drop below 12.5 V.

The diagnostics tool is disconnected.

- Thoroughly clean the plug-in connection of the fuel line using compressed air.

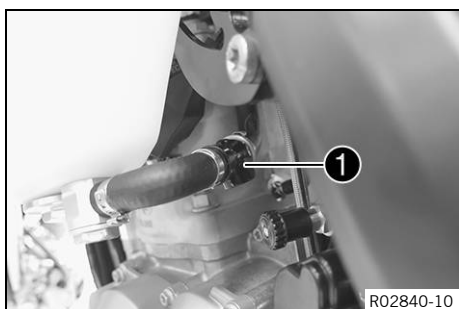

Info

Under no circumstances should dirt enter into the fuel line. Dirt in the fuel line clogs the injection valve!

- Press on the small metal plate and disconnect fuel hose connection ①.



Info

Remaining fuel may flow out of the fuel hose.

- Mount special tool ②.

Pressure testing tool (61029094000) (與 p. 369)
--

- Mount special tool ③ with nozzle code 0,60.

Testing hose (61029093000) (與 p. 369)

- Position the hose end in a fuel can.

Guideline

Minimum size, fuel can	10 l (2.6 US gal)
------------------------	-------------------

- Connect the diagnostics tool and start it.
- Select "**Actuator test**" > "**Fuel pump**".

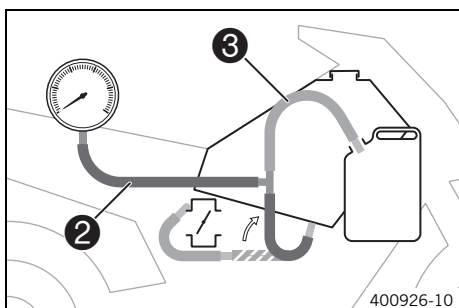

Guideline

Maximum duration of the actuator test	3 min
---------------------------------------	-------

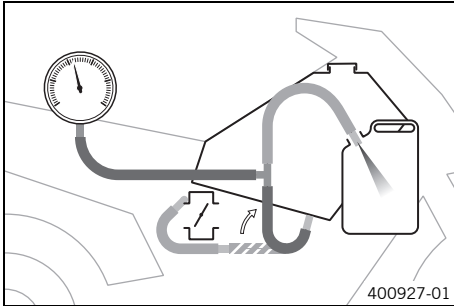

- Check the fuel pressure with the filler cap closed.

Fuel pressure	
When the fuel pump is active	3.35 ... 3.65 bar (48.6 ... 52.9 psi)

- » If the specification is not reached:
 - Open the filler cap. (🔧 p. 120)
 - Check the tank air vent system.

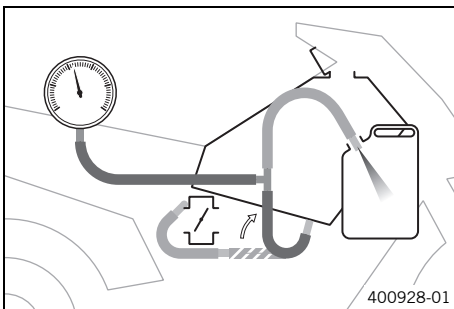

- Check the fuel pressure with the filler cap open.

Fuel pressure	
When the fuel pump is active	3.35 ... 3.65 bar (48.6 ... 52.9 psi)

- » If the specification is not reached:
 - Check that the fuel line is clear.
 - Change the fuel filter. (🔧 p. 126)
 - Change the fuel pump. (🔧 p. 129)
- Stop the "**Actuator test**" > "**Fuel pump**" by pressing the "**Quit**" button.
- Remove the special tools.
- Join the fuel hose connection.



13.1 Removing front fender

Preparatory work

- Remove the headlight mask with the headlight. (📖 p. 135)

Main work

- Remove screws ❶.

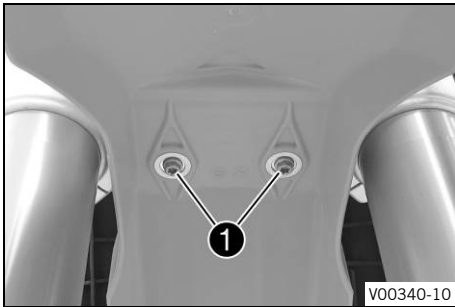

- Remove screws ❷. Take off front fender.

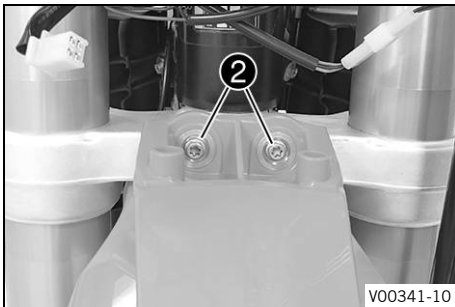

13.2 Installing front fender

Main work

- Position front fender. Mount and tighten screws ❶.

Guideline

Remaining screws, chassis	M6	10 Nm (7.4 lbf ft)
------------------------------	----	--------------------

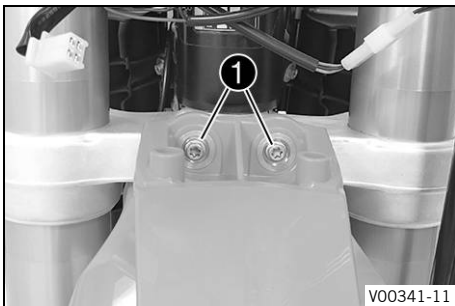

- Mount and tighten screws ❷.

Guideline

Remaining screws, chassis	M6	10 Nm (7.4 lbf ft)
------------------------------	----	--------------------

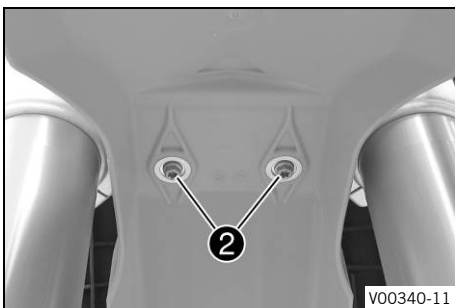

Finishing work

- Install the headlight mask with the headlight. (📖 p. 135)
- Check the headlight setting. (📖 p. 183)

13.3 Removing the headlight mask with the headlight

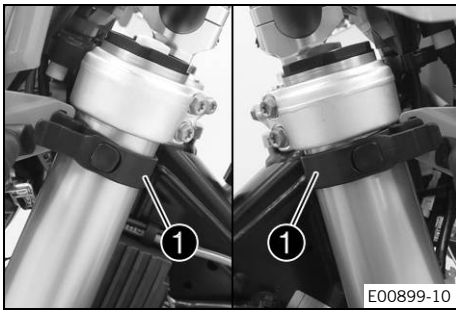

- Detach the brake line and wiring harness from the headlight mask.
- Release rubber bands ①. Slide the headlight mask up and swing it forward.

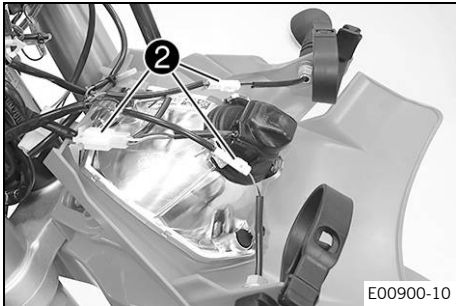

(All EXC models)

- Detach plug-in connectors ② and take off the headlight mask with the headlight.

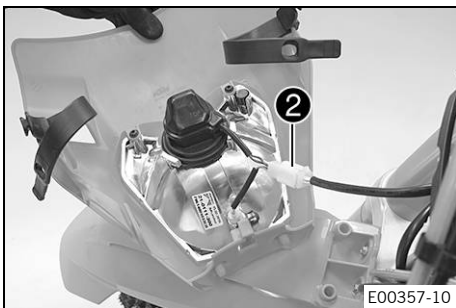

(All XC-W models)

- Detach plug-in connector ② and take off the headlight mask with the headlight.

13.4 Installing the headlight mask with the headlight

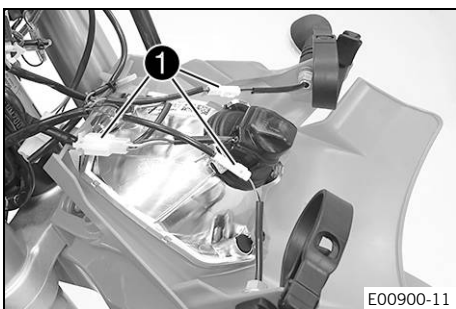

Main work

(All EXC models)

- Connect plug-in connectors ①.

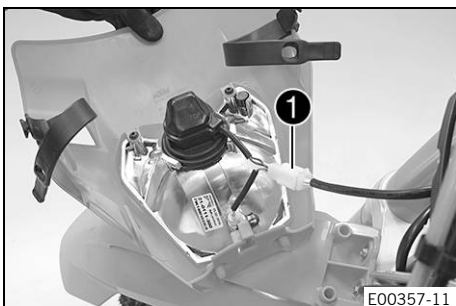

(All XC-W models)

- Connect plug-in connector ①.

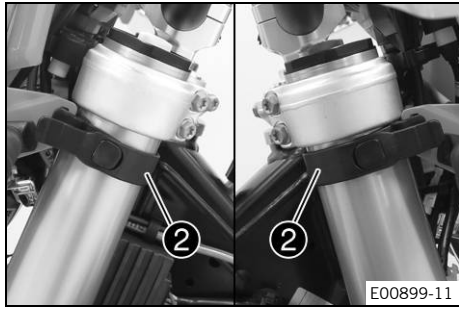

- Position the headlight mask and fix it with rubber bands ②.
 - ✓ The holding lugs engage in the fender.
- Position the brake line and wiring harness in the brake line guide.

Finishing work

- Check the headlight setting. (📖 p. 183)

14.1 Checking the tire air pressure

i Info

Low tire air pressure leads to abnormal wear and overheating of the tire. Correct tire air pressure ensures optimal riding comfort and maximum tire service life.

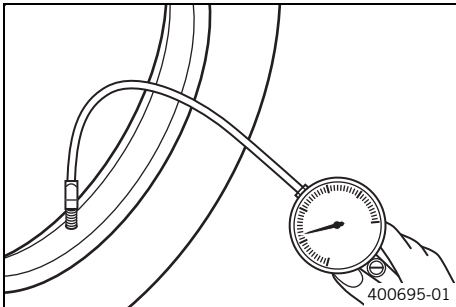

- Remove the dust cap.
- Check the tire air pressure when the tires are cold.

Tire air pressure, road (All EXC models)	
front	1.5 bar (22 psi)
rear	1.5 bar (22 psi)

Tire air pressure off road	
front	1.0 bar (15 psi)
rear	1.0 bar (15 psi)

- » If the tire pressure does not meet specifications:
 - Correct the tire pressure.
- Mount the dust cap.



14.2 Checking the tire condition

i Info

Only mount tires approved and/or recommended by KTM. Other tires could have a negative effect on handling characteristics. The type, condition, and air pressure of the tires all have a major impact on the handling of the motorcycle. Worn tires have a negative effect on handling characteristics, especially on wet surfaces.

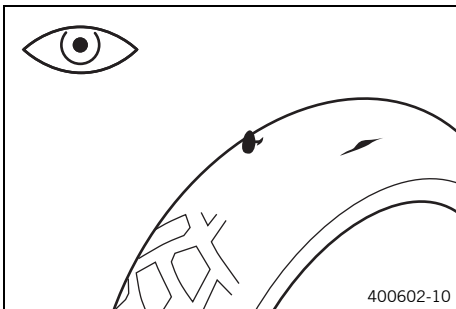

- Check the front and rear tires for cuts, run-in objects, and other damage.
 - » If the tires have cuts, run-in objects, or other damage:
 - Change the tires.
- Check the tread depth.

i Info

Adhere to the legally required minimum tread depth.

Minimum tread depth	$\geq 2 \text{ mm } (\geq 0.08 \text{ in})$
---------------------	---

- » If the tread depth is less than the minimum tread depth:
 - Change the tires.

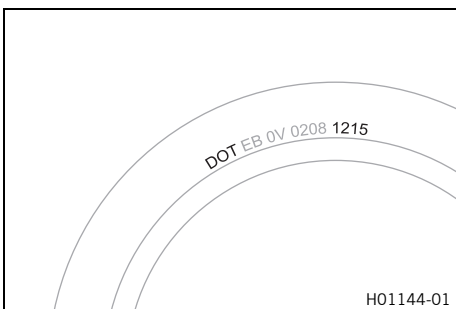

- Check the tire age.

i Info

The tire date of manufacture is usually contained in the tire label and is indicated by the last four digits of the **DOT** number. The first two digits indicate the week of manufacture and the last two digits the year of manufacture.

KTM recommends that the tires be changed after 5 years at the latest, regardless of the actual state of wear.

- » If the tires are more than 5 years old:
 - Change the tires.

14.3 Checking the wheel bearing for play

Preparatory work

- Raise the motorcycle with a lift stand. (📖 p. 12)
- Place a load on the rear of the vehicle.
- ✓ The front wheel is not in contact with the ground.

Main work

- Move the front wheel from side to side.

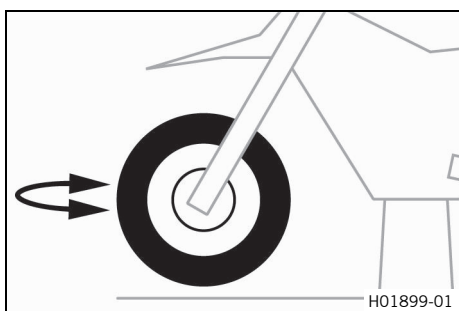

i Info

Hold the fork leg to check it.

- » If there is detectable play:
 - Change front wheel bearing. (📖 p. 143)

- Place a load on the front of the vehicle.
- ✓ The rear wheel is not in contact with the ground.
- Move the rear wheel from side to side.

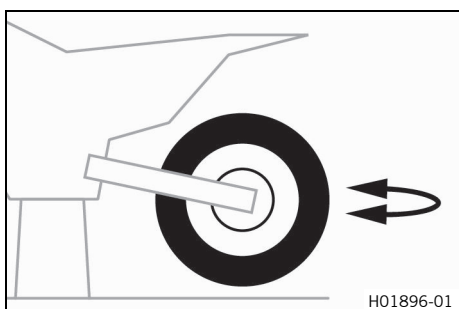

i Info

Hold the swingarm to check it.

- » If there is detectable play:
 - Change the rear wheel bearing. (📖 p. 147)

Finishing work

- Remove the motorcycle from the lift stand. (📖 p. 12)

14.4 Checking the brake discs



Warning

Danger of accidents Worn-out brake discs reduce the braking effect.

- Make sure that worn-out brake discs are replaced immediately.

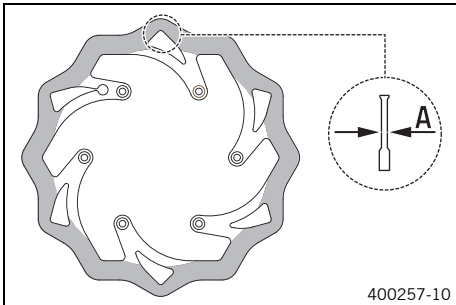

- Check the front and rear brake disc thickness at multiple points for the dimension **A**.



Info

Wear reduces the thickness of the brake disc around the contact surface of the brake linings.

Brake discs - wear limit (All standard EXC/XC-W models)	
front	2.5 mm (0.098 in)
rear	3.5 mm (0.138 in)
Brake discs - wear limit (All Six Days models)	
front	2.5 mm (0.098 in)
rear	3.7 mm (0.146 in)

- » If the brake disc thickness is less than the specified value:
 - Change the front brake disc. (📖 p. 142)
 - Change the rear brake disc. (📖 p. 146)
- Check the front and rear brake discs for damage, cracking, and deformation.
 - » If the brake disc exhibits damage, cracking, or deformation:
 - Change the front brake disc. (📖 p. 142)
 - Change the rear brake disc. (📖 p. 146)



14.5 Checking the rim run-out



Warning

Danger of accidents Incorrectly tensioned spokes impair the handling characteristic and result in secondary damage.

The spokes break due to being overloaded if they are too tightly tensioned. If the tension in the spokes is too low, then lateral and radial run-out will form in the wheel. Other spokes will become looser as a result.

- Check spoke tension regularly, and in particular on a new vehicle.



Info

A loose spoke can unbalance the wheel and other spokes may loosen within a short period. If the spokes are too tight, they can break due to local overload. Check the spoke tension regularly, especially on a new motorcycle.

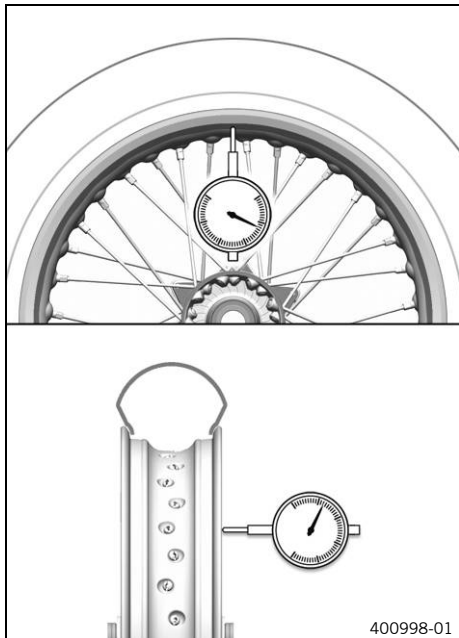

- Check for lateral and radial run-out of the rims.

Lateral runout	
Outside the rim joint	< 1.8 mm (< 0.071 in)

Radial runout	
Outside the rim joint	< 1.8 mm (< 0.071 in)

- » If the measured value is greater than the specified value:
 - Center the rim.

i Info
Center the rim by pulling the spoke nipple on the other side of the rim run-out. If there is significant deformation, change the rim.

- Correct the spoke tension.

14.6 Checking spoke tension



Warning

Danger of accidents Incorrectly tensioned spokes impair the handling characteristic and result in secondary damage.

The spokes break due to being overloaded if they are too tightly tensioned. If the tension in the spokes is too low, then lateral and radial run-out will form in the wheel. Other spokes will become looser as a result.

- Check spoke tension regularly, and in particular on a new vehicle.

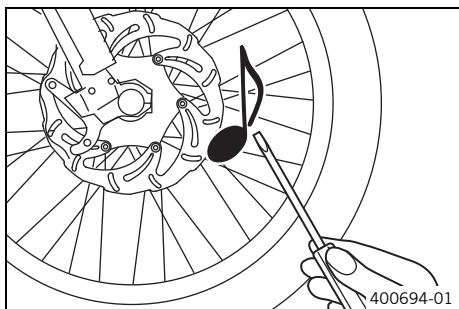

- Strike each spoke briefly using a screwdriver blade.



Info

The frequency of the sound depends on the spoke length and spoke diameter. If you hear different tone frequencies from different spokes of equal length and diameter, this is an indication of different spoke tensions.

You should hear a high note.

- » If the spoke tension differs:
 - Correct the spoke tension.

- Check the spoke torque.

Guideline

Spoke nipple, front wheel	M4.5	6 Nm (4.4 lbf ft)
Spoke nipple, rear wheel	M4.5	6 Nm (4.4 lbf ft)

Torque wrench kit (58429094000) (🗉 p. 368)

14.7 Front wheel

14.7.1 Removing the front wheel

Preparatory work

- Raise the motorcycle with a lift stand. (📖 p. 12)

Main work

- Press the brake caliper onto the brake disc by hand in order to push back the brake pistons.



Info

Make sure that you do not press the brake caliper against the spokes when pushing back the brake pistons.

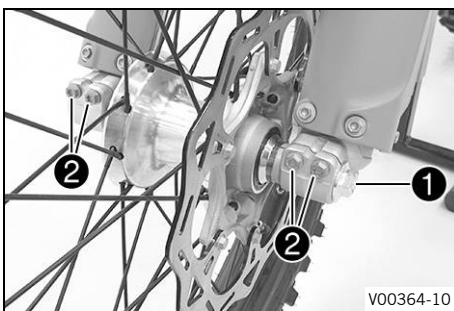

- Loosen screw ① by several rotations.
- Loosen screws ②.
- Press on screw ① to push the wheel spindle out of the axle clamp.
- Remove screw ①.

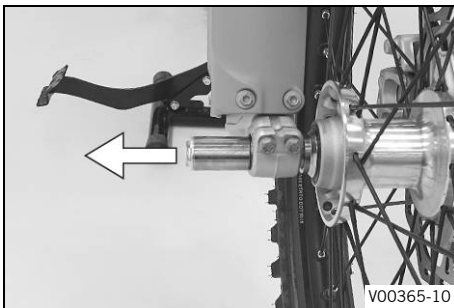

Warning

Danger of accidents Damaged brake discs reduce the braking effect.

- Always lay the wheel down in such a way that the brake disc is not damaged.

- Hold the front wheel and remove the wheel spindle. Take the front wheel out of the fork.



Info

Do not pull the hand brake lever when the front wheel is removed.

- Remove spacers ③.

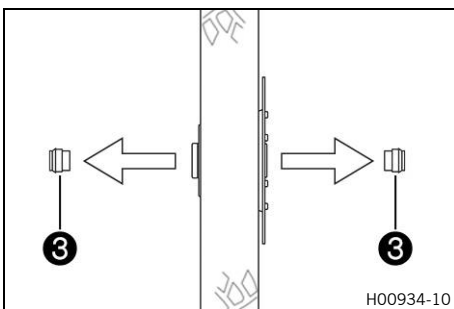

14.7.2 Installing the front wheel



Warning

Danger of accidents Oil or grease on the brake discs reduces the braking effect.

- Always keep the brake discs free of oil and grease.
- Clean the brake discs with brake cleaner when necessary.

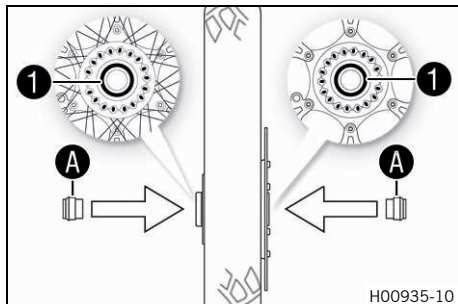

- Check the wheel bearing for damage and wear.
 - » If the wheel bearing is damaged or worn:
 - Change front wheel bearing. (📖 p. 143)
- Clean and grease shaft seal rings 1 and contact surface A of the spacers.

Long-life grease (📖 p. 360)

- Insert the spacers.
- Clean and grease the wheel spindle.

Long-life grease (📖 p. 360)

- Lift the front wheel into the fork, position it, and insert the wheel spindle.

✓ The brake linings are correctly positioned.

- Mount and tighten screw 2.

Guideline

Screw, front wheel spindle	M20x1.5	35 Nm (25.8 lbf ft)
----------------------------	---------	---------------------

- Operate the hand brake lever several times until the brake linings are seated correctly against the brake disc.
- Remove the motorcycle from the lift stand. (📖 p. 12)
- Operate the front brake and compress the fork a few times firmly.

✓ The fork legs straighten.

- Tighten screws 3.

Guideline

Screw, fork stub	M8	15 Nm (11.1 lbf ft)
------------------	----	---------------------

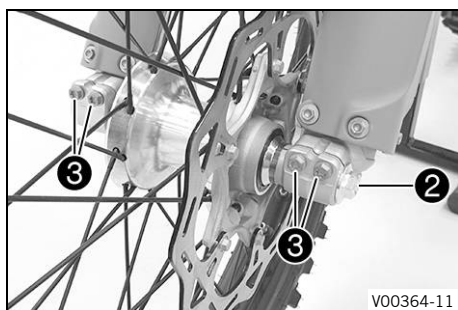

14.7.3 Changing the front brake disc



Info

If the brake discs are changed, the brake linings must also be changed.

Preparatory work

- Raise the motorcycle with a lift stand. (📖 p. 12)
- Remove the front wheel. (📖 p. 141)

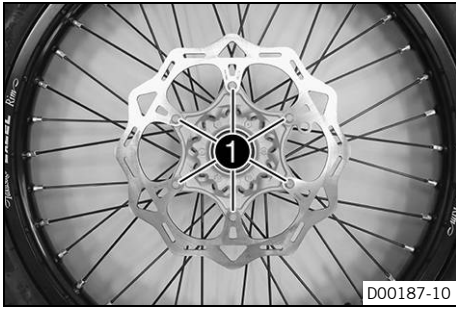

Main work

(All standard EXC/XC-W models)

- Remove screws 1. Remove the brake disc.
- Clean the contact surface of the brake disc.
- Position the new brake disc with the label facing outward.
- Mount and tighten screws 1.

Guideline

Screw, front brake disc	M6	14 Nm (10.3 lbf ft) Loctite®243™
----------------------------	----	--



(All Six Days models)

- Remove screws 1. Remove the brake disc.
- Clean the contact surface of the brake disc.
- Position the new brake disc with the label facing outward.
- Mount and tighten screws 1.

Guideline

Screw, front brake disc	M6	14 Nm (10.3 lbf ft) Loctite®243™
----------------------------	----	--

Finishing work

- Install the front wheel. (🗨️ p. 142)

14.7.4 Changing front wheel bearing

Preparatory work

- Raise the motorcycle with a lift stand. (🗨️ p. 12)
- Remove the front wheel. (🗨️ p. 141)

Main work

- Remove shaft seal rings 1 and 2.

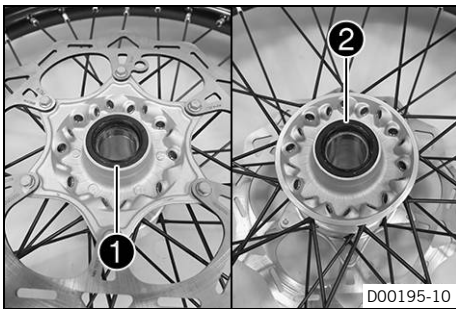

- Press out bearing 3 using a suitable tool.



Info

Spacing tube 4 can be pushed aside.

- Remove spacing tube 4.

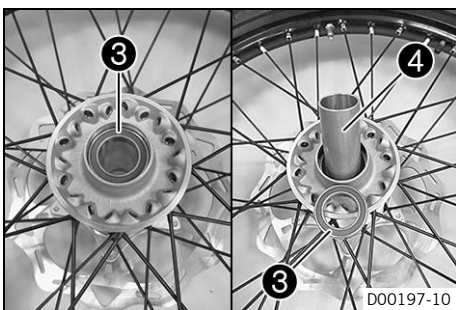

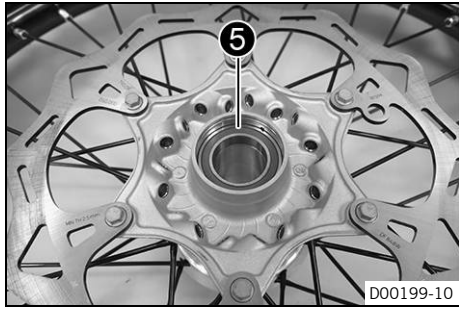

- Press out bearing **5** using a suitable tool.
- Press in new bearing **5** all the way using a suitable tool.



Info

Only press the bearing in via the outer ring otherwise the bearing will be damaged when it is pressed in.

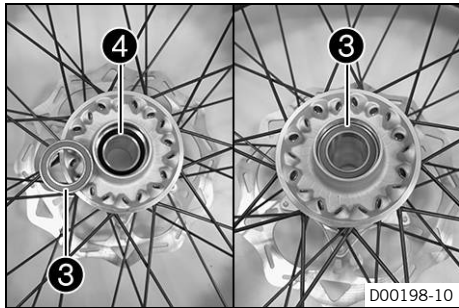

- Clean, grease, and mount spacing tube **4**.

Long-life grease (📖 p. 360)

- Press in new bearing **3** all the way using a suitable tool.



Info

Only press the bearing in via the outer ring otherwise the bearing will be damaged when it is pressed in.

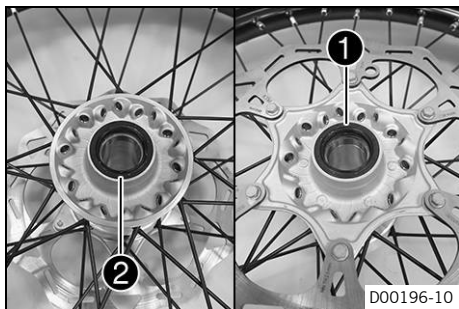

- Grease new shaft seal rings **2** and **1** and press in until they are flush.

Finishing work

- Install the front wheel. (📖 p. 142)

14.8 Rear wheel

14.8.1 Removing the rear wheel

Preparatory work

- Raise the motorcycle with a lift stand. (📖 p. 12)

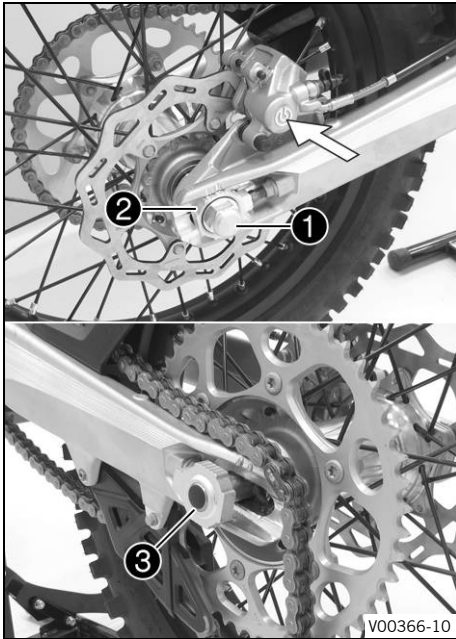

Main work

- Press the brake caliper onto the brake disc by hand in order to push back the brake piston.

i Info
Make sure when pushing back the brake piston that you do not press the brake caliper against the spokes.

- Remove nut ①.
- Remove chain adjuster ②. Pull out wheel spindle ③ far enough to allow the rear wheel to be pushed forward.
- Push the rear wheel forward as far as possible. Remove the chain from the rear sprocket.

i Info
Cover the components to protect them against damage.

! Warning
Danger of accidents Damaged brake discs reduce the braking effect.
- Always lay the wheel down in such a way that the brake disc is not damaged.

- Hold the rear wheel and remove the wheel spindle. Take the rear wheel out of the swingarm.

i Info
Do not operate the foot brake lever when the rear wheel is removed.

- Remove spacers ④.

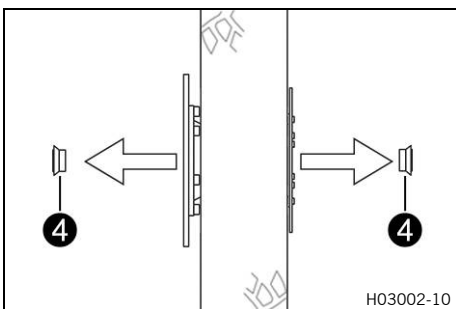

14.8.2 Installing the rear wheel

! Warning
Danger of accidents Oil or grease on the brake discs reduces the braking effect.
- Always keep the brake discs free of oil and grease.
- Clean the brake discs with brake cleaner when necessary.

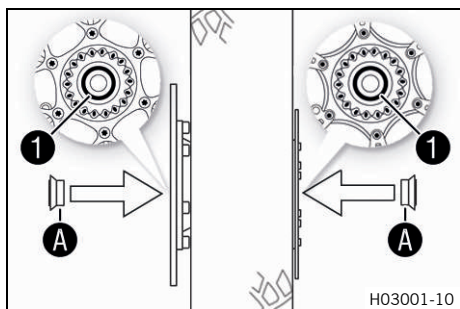

Main work

- Check the wheel bearing for damage and wear.
 - » If the wheel bearing is damaged or worn:
 - Change the rear wheel bearing. (📖 p. 147)
- Clean and grease shaft seal rings 1 and contact surface A of the spacers.

Long-life grease (📖 p. 360)

- Insert the spacers.
- Clean and grease the wheel spindle.

Long-life grease (📖 p. 360)

- Position the rear wheel and insert wheel spindle 2.
- Mount the chain.
 - ✓ The brake linings are correctly positioned.

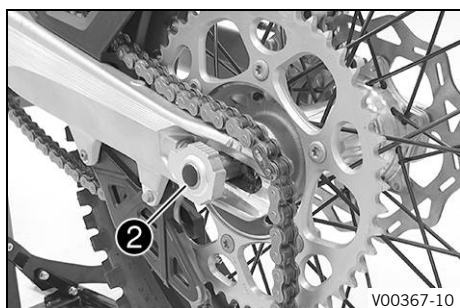

- Position chain adjuster 3. Mount nut 4, but do not tighten it yet.
- Make sure that chain adjusters 3 are fitted correctly on adjusting screws 5.
- Check the chain tension. (📖 p. 150)
- Tighten nut 4.

Guideline

Nut, rear wheel spindle	M20x1.5	80 Nm (59 lbf ft)
-------------------------	---------	-------------------

Info

The wide adjustment range of the chain adjusters (32 mm (1.26 in)) enables different secondary ratios with the same chain length.
Chain adjusters 3 can be turned by 180°.

- Operate the foot brake lever repeatedly until the brake linings are in contact with the brake disc and there is a pressure point.

Finishing work

- Remove the motorcycle from the lift stand. (📖 p. 12)

14.8.3 Changing the rear brake disc



Info

If the brake discs are changed, the brake linings must also be changed.

Preparatory work

- Raise the motorcycle with a lift stand. (📖 p. 12)
- Remove the rear wheel. (📖 p. 144)



Main work

(All standard EXC/XC-W models)

- Remove screws ①. Remove the brake disc.
- Clean the contact surface of the brake disc.
- Position the new brake disc with the label facing outward.
- Mount and tighten screws ①.

Guideline

Screw, rear brake disc	M6	14 Nm (10.3 lbf ft) Loctite®243™
---------------------------	----	--



(All Six Days models)

- Remove screws ①. Remove the brake disc.
- Clean the contact surface of the brake disc.
- Position the new brake disc with the label facing outward.
- Mount and tighten screws ①.

Guideline

Screw, rear brake disc	M6	14 Nm (10.3 lbf ft) Loctite®243™
---------------------------	----	--

Finishing work

- Install the rear wheel. (📖 p. 145)
- Remove the motorcycle from the lift stand. (📖 p. 12)

14.8.4 Changing the rear wheel bearing

Preparatory work

- Raise the motorcycle with a lift stand. (📖 p. 12)
- Remove the rear wheel. (📖 p. 144)

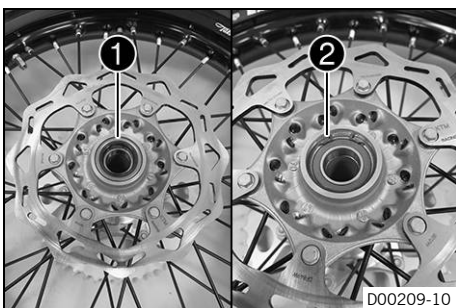

Main work

- Remove shaft seal ring ①.
- Remove lock ring ②.

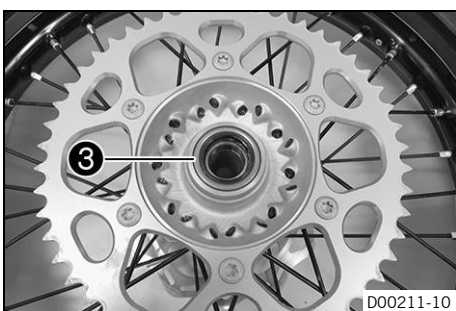

- Remove shaft seal ring ③.

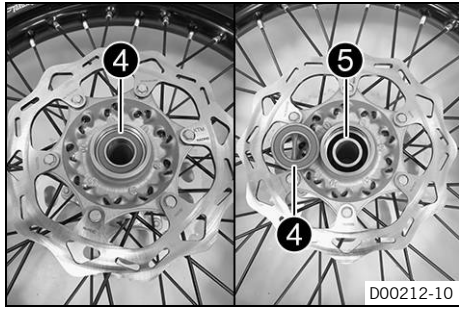

- Using a suitable tool, press bearing 4 out from the inside to the outside.
- Remove spacing tube 5.

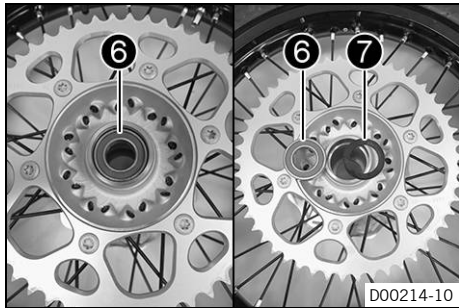

- Using a suitable tool, press bearing 6 out from the inside to the outside.
- Check spacer washer 7 for damage and wear.
 - » If the spacer washer is damaged or worn:
 - Replace the spacer washer.

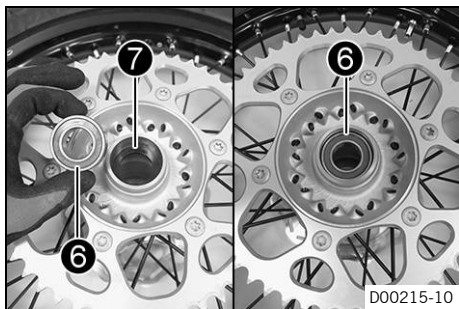

- Position spacer washer 7.
- Press new bearing 6 all the way in from the outside to the inside.



Info

Only press the bearing in via the outer ring otherwise the bearing will be damaged when it is pressed in.

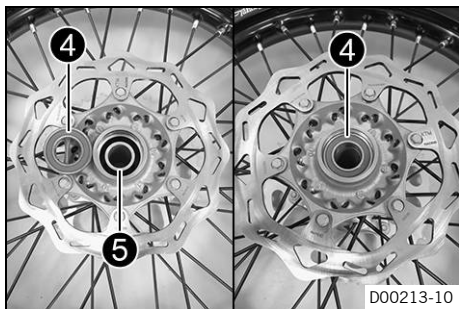

- Clean, grease, and mount spacing tube 5.



Long-life grease (📖 p. 360)

- Press new bearing 4 all the way in from the outside to the inside.



Info

Only press the bearing in via the outer ring otherwise the bearing will be damaged when it is pressed in.

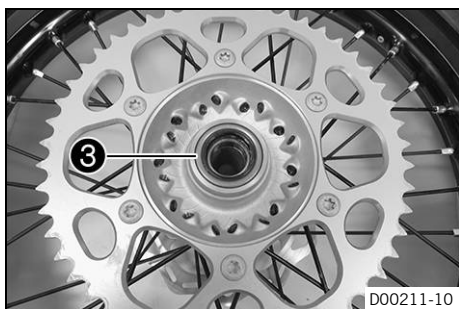

- Grease new shaft seal ring 3 and press it in until it is flush.

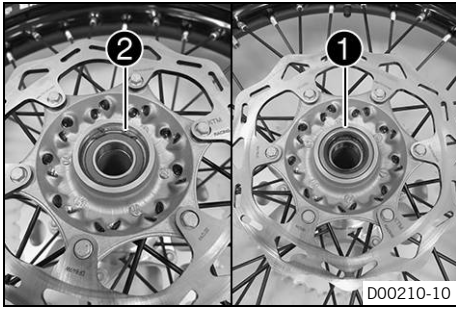

- Mount lock ring ②.
- ✓ The lock ring engages audibly.
- Grease new shaft seal ring ① and press it in until it is flush.

Finishing work

- Install the rear wheel. (📖 p. 145)
- Remove the motorcycle from the lift stand. (📖 p. 12)



14.8.5 Checking the chain for dirt

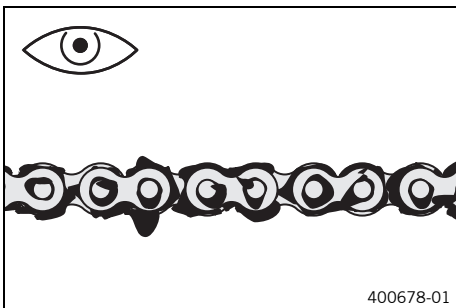

- Check the chain for heavy soiling.
 - » If the chain is very dirty:
 - Clean the chain. (📖 p. 149)



14.8.6 Cleaning the chain



Warning

Danger of accidents Oil or grease on the tires reduces the road grip.

- Remove the lubricant from the tires using a suitable cleaning agent.



Warning

Danger of accidents Oil or grease on the brake discs reduces the braking effect.

- Always keep the brake discs free of oil and grease.
- Clean the brake discs with brake cleaner when necessary.



Note

Environmental hazard Hazardous substances cause environmental damage.

- Dispose of oils, grease, filters, fuel, cleaning agents, brake fluid, etc., correctly and in compliance with the applicable regulations.



Info

The service life of the chain depends largely on its maintenance.

Preparatory work

- Raise the motorcycle with a lift stand. (📖 p. 12)

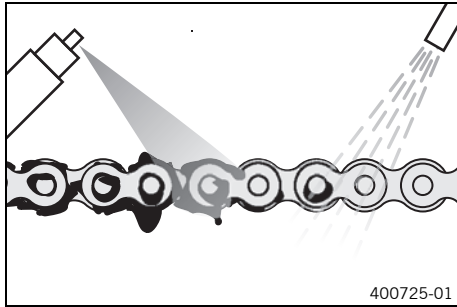

Main work

- Rinse off loose dirt with a soft jet of water.
- Remove old grease residue with chain cleaner.

Chain cleaner (📖 p. 360)

- After drying, apply chain spray.

Off-road chain spray (📖 p. 361)

Finishing work

- Remove the motorcycle from the lift stand. (📖 p. 12)

14.8.7 Checking the chain tension



Warning

Danger of accidents Incorrect chain tension damages components and results in accidents.

If the chain is tensioned too much, the chain, engine sprocket, rear sprocket, transmission and rear wheel bearings wear more quickly. Some components may break if overloaded.

If the chain is too loose, the chain may fall off the engine sprocket or the rear sprocket. As a result, the rear wheel locks or the engine will be damaged.

- Check the chain tension regularly.
- Set the chain tension in accordance with the specification.

Preparatory work

- Raise the motorcycle with a lift stand. (📖 p. 12)

Main work

- Pull the chain at the end of the chain sliding piece upward to measure chain tension **A**.



Info

The bottom chain section **1** must be taut.

When the chain guard is mounted, it must be possible to pull up the chain at least to the point where it makes contact with chain guard **B**.

Chain wear is not always even, so you should repeat this measurement at different chain positions.

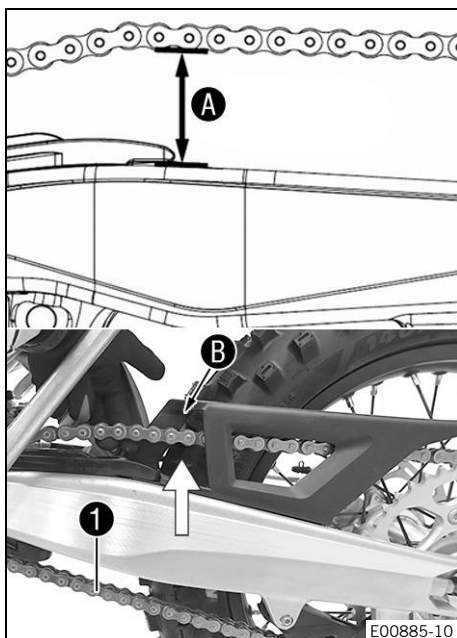

Chain tension	55 ... 58 mm (2.17 ... 2.28 in)
---------------	---------------------------------

- » If the chain tension does not meet specifications:
 - Adjust the chain tension. (📖 p. 153)

Finishing work

- Remove the motorcycle from the lift stand. (📖 p. 12)

14.8.8 Checking the chain, rear sprocket, engine sprocket, and chain guide

Preparatory work

- Raise the motorcycle with a lift stand. (📖 p. 12)

Main work

- Shift the transmission to idle.
- Check the chain, rear sprocket and engine sprocket for wear.
 - » If the chain, rear sprocket or engine sprocket is worn:
 - Change the drivetrain kit. (📖 p. 154)

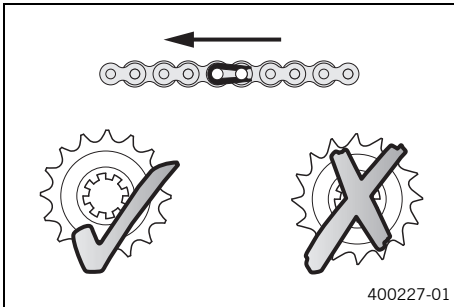

400227-01

i Info
The engine sprocket, rear sprocket and chain should always be replaced together.

- Pull at the top part of the chain with the specified weight **A**.

Guideline

Weight, chain wear measurement	10 ... 15 kg (22 ... 33 lb.)
--------------------------------	------------------------------

- Measure distance **B** of 18 chain rollers in the lower chain section.

i Info
Chain wear is not always even, so you should repeat this measurement at different chain positions.

Maximum distance B from 18 chain rollers at the longest chain section	272 mm (10.71 in)
--	-------------------

- » If distance **B** is greater than the specified measurement:
 - Change the drivetrain kit. (📖 p. 154)

i Info
When a new chain is mounted, the rear sprocket and engine sprocket should also be changed. New chains wear out faster on old, worn sprockets.

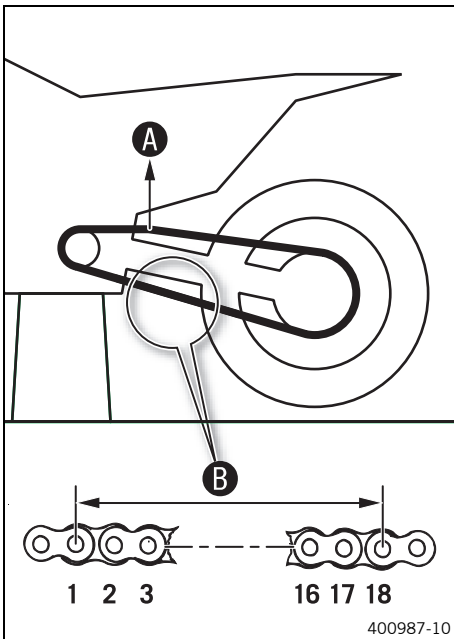

400987-10

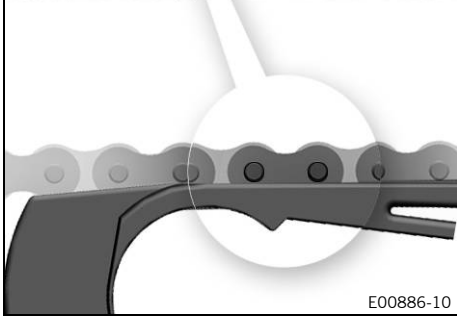

E00886-10

- Check the chain sliding guard for wear.
 - » If the lower edge of the chain pins is in line with, or below, the chain sliding guard:
 - Change the chain sliding guard.
- Check that the chain sliding guard is firmly seated.
 - » If the chain sliding guard is loose:
 - Tighten the screws on the chain sliding guard.

Guideline

Screw, chain sliding guard	M6	6 Nm (4.4 lbf ft) Loctite®243™
----------------------------	----	--

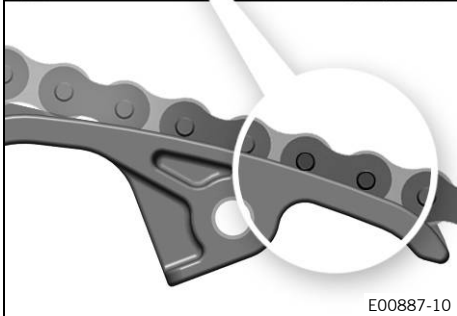

E00887-10

- Check the chain sliding piece for wear.
 - » If the lower edge of the chain pins is in line with or below the chain sliding piece:
 - Change the chain sliding piece.
- Check that the chain sliding piece is firmly seated.
 - » If the chain sliding piece is loose:
 - Tighten the screw on the chain sliding piece.

Guideline

Screw, chain sliding piece	M8	15 Nm (11.1 lbf ft)
----------------------------	----	------------------------

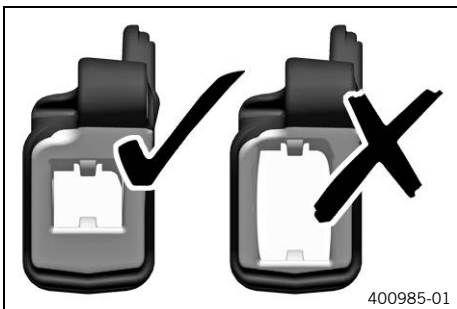

400985-01

- Check the chain guide for wear.



Info

Wear can be seen on the front of the chain guide.

- » If the light part of the chain guide is worn:
 - Change the chain guide.

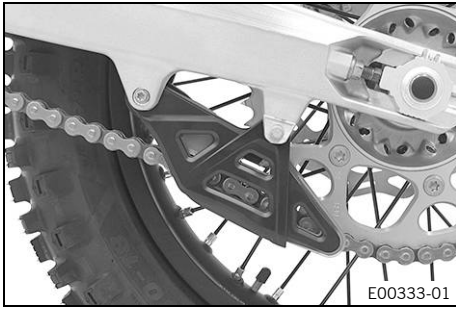

- Check that the chain guide is firmly seated.
 - » If the chain guide is loose:
 - Tighten the screws on the chain guide.

Guideline

Remaining screws, chassis	M6	10 Nm (7.4 lbf ft)
---------------------------	----	--------------------

Finishing work

- Remove the motorcycle from the lift stand. (📖 p. 12)

14.8.9 Adjusting the chain tension



Warning

Danger of accidents Incorrect chain tension damages components and results in accidents.

If the chain is tensioned too much, the chain, engine sprocket, rear sprocket, transmission and rear wheel bearings wear more quickly. Some components may break if overloaded.

If the chain is too loose, the chain may fall off the engine sprocket or the rear sprocket. As a result, the rear wheel locks or the engine will be damaged.

- Check the chain tension regularly.
- Set the chain tension in accordance with the specification.

Preparatory work

- Raise the motorcycle with a lift stand. (📖 p. 12)
- Check the chain tension. (📖 p. 150)

Main work

- Loosen nut ❶.
- Loosen nuts ❷.
- Adjust the chain tension by turning adjusting screws ❸ left and right.

Guideline

Chain tension	55 ... 58 mm (2.17 ... 2.28 in)
---------------	---------------------------------

Turn adjusting screws ❸ on the left and right so that the markings on the left and right chain adjusters are in the same position relative to reference marks A. The rear wheel is then correctly aligned.

- Tighten nuts ❷.
- Make sure that chain adjusters ❹ are fitted correctly on adjusting screws ❸.
- Tighten nut ❶.

Guideline

Nut, rear wheel spindle	M20x1.5	80 Nm (59 lbf ft)
-------------------------	---------	-------------------

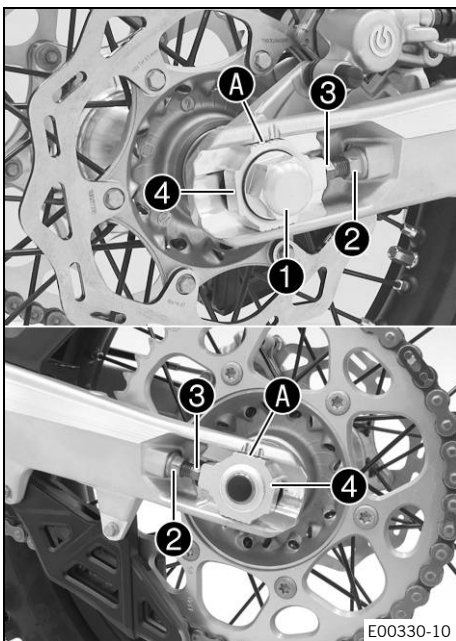

i Info

The wide adjustment range of the chain adjusters (32 mm (1.18 in)) enables different secondary ratios with the same chain length.
Chain adjusters **4** can be turned by 180°.

Finishing work

- Remove the motorcycle from the lift stand. (📖 p. 12)

14.8.10 Changing the drivetrain kit

Preparatory work

- Raise the motorcycle with a lift stand. (📖 p. 12)
- Remove the air filter box cover. (📖 p. 116)

Main work

- Remove screw **1**.
- Remove screw **2**.
- Take the engine sprocket cover off to the front.

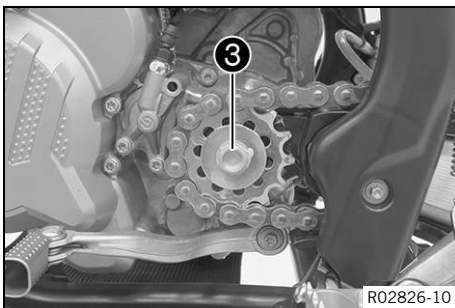
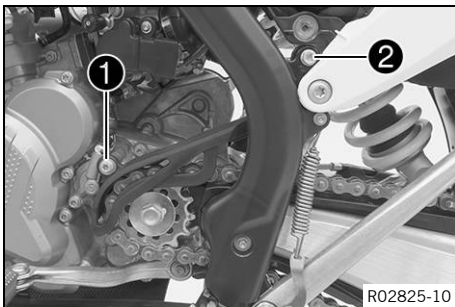

- Have an assistant operate the rear brake.
- Remove screw **3** with the washer.

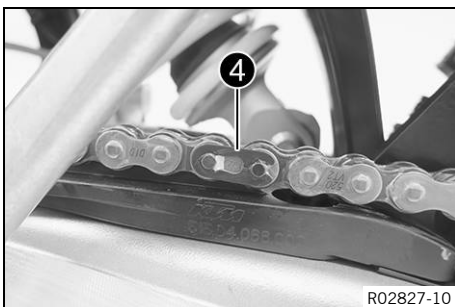

- Remove connecting link **4** of the chain.

i Info

Cover the components to protect them against damage.

- Take off the chain.
- Remove the rear wheel. (📖 p. 144)

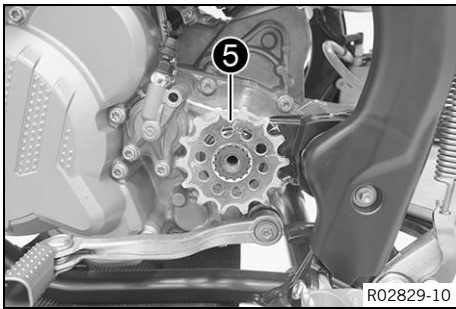

- Remove engine sprocket **5**.

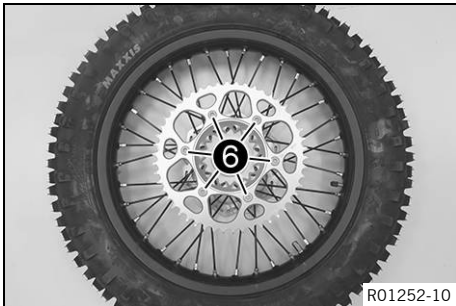

(All standard EXC/XC-W models)

- Remove fittings **6**. Take off the rear sprocket.
- Position the new rear sprocket. Mount and tighten the fittings.

Guideline

Nut, rear sprocket screw	M8	35 Nm (25.8 lbf ft) Loctite®2701™
--------------------------	----	---

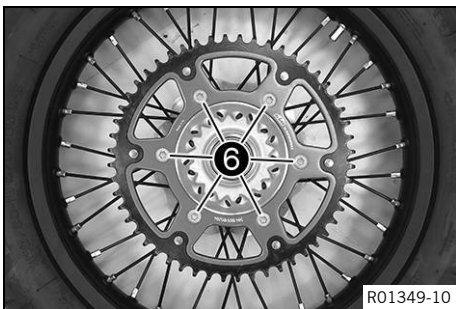

(All Six Days models)

- Remove fittings **6**. Take off the rear sprocket.
- Position the new rear sprocket. Mount and tighten the fittings.

Guideline

Nut, rear sprocket screw	M8	35 Nm (25.8 lbf ft) Loctite®2701™
--------------------------	----	---

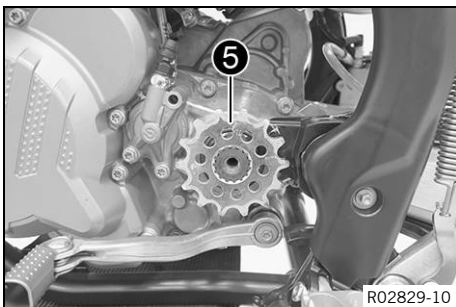

- Slide new engine sprocket **5** onto the countershaft.
- Install the rear wheel. (📖 p. 145)

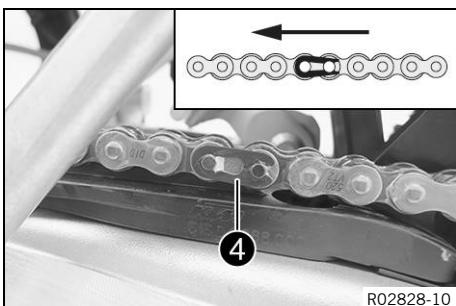

- Mount the new chain.
- Connect the chain with connecting link **4**.

Guideline

The closed side of the chain joint lock must face in the direction of travel.

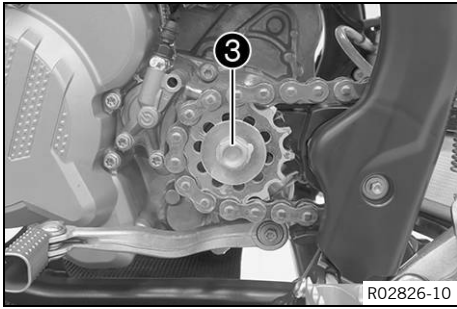

- Have an assistant operate the rear brake.
- Mount and tighten screw **3** with the washer.

Guideline

Screw, drive chain engine sprocket	M10	60 Nm (44.3 lbf ft) Loctite®2701™
------------------------------------	-----	---

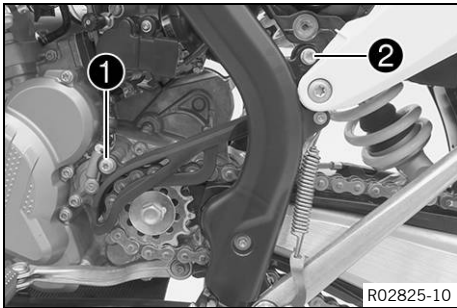

- Position the engine sprocket cover.
- Mount and tighten screw **1**.

Guideline

Remaining screws, chassis	M6	10 Nm (7.4 lbf ft)
---------------------------	----	--------------------

- Mount and tighten screw **2**.

Guideline

Screw, engine sprocket cover	M8	20 Nm (14.8 lbf ft)
------------------------------	----	---------------------

Finishing work

- Install the air filter box cover. (📖 p. 116)
- Check the chain tension. (📖 p. 150)
- Remove the motorcycle from the lift stand. (📖 p. 12)

15.1 Ignition curve plug-in connector

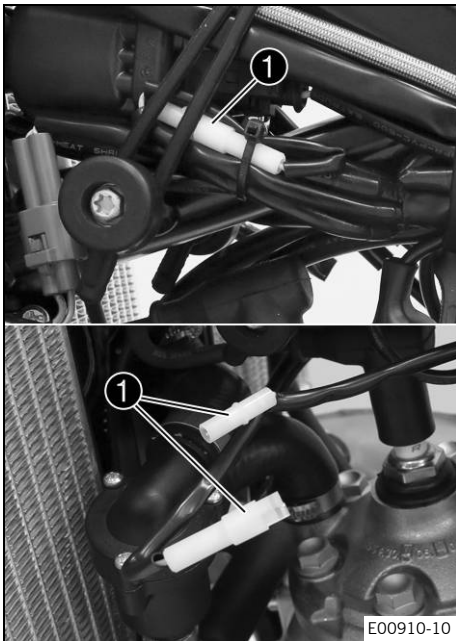

Plug-in connector **1** of the ignition timing map adjustment is located on the frame under the fuel tank.

i Info

The ignition timing map connector has no function in the homologated (restricted) condition of the motorcycle.

Possible states

- Soft – The plug-in connector of the ignition timing map adjustment is disconnected to achieve better rideability.
- Performance – The plug-in connector of the ignition timing map adjustment is joined to achieve higher performance.

15.2 Changing the main fuse



Warning

Fire hazard Incorrect fuses overload the electrical system.

- Only use fuses with the required ampere value.
- Do not bypass or repair fuses.



Info

The main fuse protects all power consumers of the vehicle.

Preparatory work

(All EXC models)

- Press and hold the kill switch \otimes while the engine is idling until the engine stops.

(All XC-W models)

- Press and hold the kill switch \otimes while the engine is idling until the engine stops.
- Remove the seat. (📖 p. 121)

Main work

- Pull the EFI control unit **1** upward off the rubber plugs **2** and hang to the side.

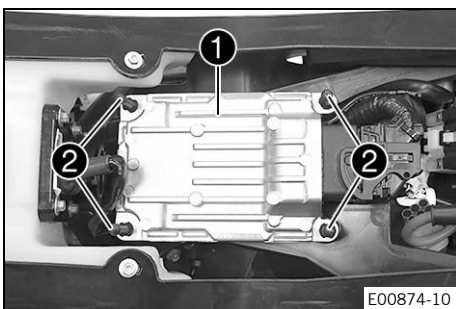

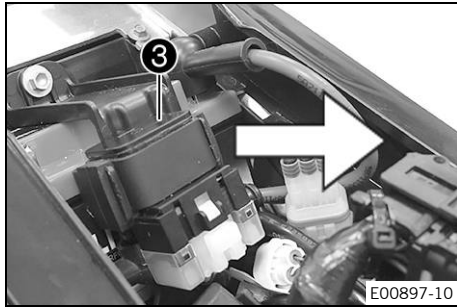

- Pull starter relay ③ from the holder.

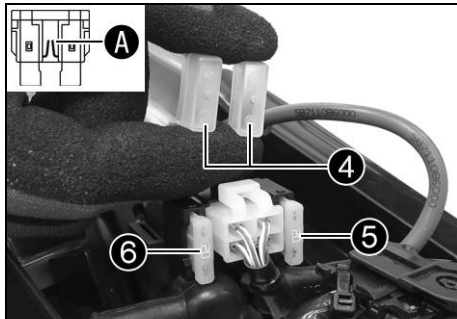

- Take off protection caps ④.
- Remove faulty main fuse ⑤.

i Info

A faulty fuse has a burned-out fuse wire **A**.
A spare fuse ⑥ is located in the starter relay.

- Install a new main fuse.

Fuse (58011109120) (📖 p. 317)

- Check that the electrical system is functioning properly.

i Tip

Insert a spare fuse so that it is available if needed.

- Attach the protection caps ④.
- Mount the starter relay ③ onto the holder and route the cable.

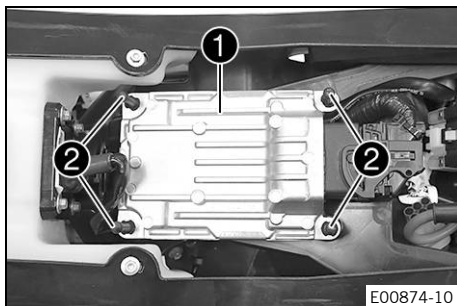
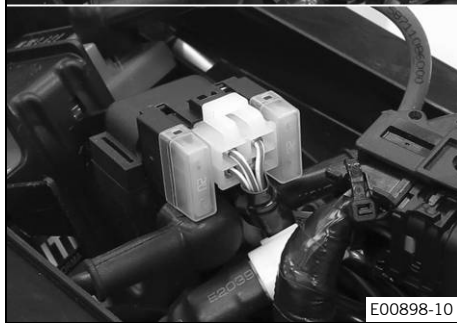

- Mount the EFI control unit ① on the rubber lugs ②.

Finishing work

- Mount the seat. (📖 p. 121)

15.3 Changing the fuses of individual power consumers

i Info

The fuse box containing the fuses of individual power consumers is located under the seat.

Preparatory work

(All EXC models)

- Press and hold the kill switch \otimes while the engine is idling until the engine stops.

(All XC-W models)

- Press and hold the kill switch \otimes while the engine is idling until the engine stops.
- Remove the seat. (🗨 p. 121)

Main work

- Pull the EFI control unit **1** upward off the rubber plugs **2** and hang to the side.

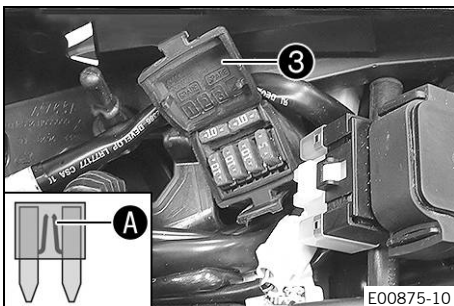
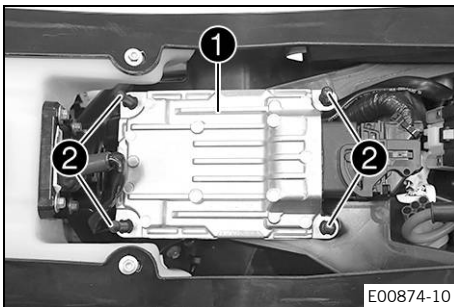

- Open fuse box cover **3**.
- Remove the faulty fuse.

Guideline

(All EXC models)

Fuse 1 - 10 A - EFI control unit, lambda sensor, oil pump, combination instrument, fuel injection, diagnostics connector
Fuse 2 - 10 A - horn, brake light, radiator fan (optional), turn signal (optional)
Fuse 3 - 10 A - high beam, low beam, parking light, tail light, license plate lamp
Fuse 4 - 5 A - fuel pump

(All XC-W models)

Fuse 1 - 10 A - EFI control unit, oil pump, combination instrument, fuel injection, diagnostics connector
Fuse 2 - 10 A - radiator fan (optional)
Fuse 3 - 10 A - low beam, parking light, tail light
Fuse 4 - 5 A - fuel pump

Fuses **res** - 10 A - spare fuse

i Info

A faulty fuse has a burned-out fuse wire **A**.



Warning

Fire hazard Incorrect fuses overload the electrical system.

- Only use fuses with the required ampere value.
- Do not bypass or repair fuses.

- Insert spare fuse with the correct rating only.

Fuse (75011088010) (📖 p. 317)

Fuse (75011088005) (📖 p. 317)



Tip

Replace the spare fuse in the fuse box so that it is available if needed.

- Check that the power consumer is functioning properly.
- Close the fuse box cover ❸.
- Mount the EFI control unit ❶ on the rubber lugs ❷.

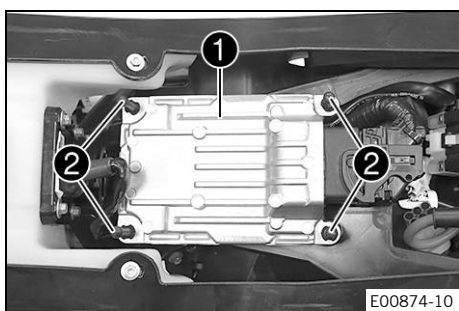

Finishing work

- Mount the seat. (📖 p. 121)

15.4 Disconnecting the negative cable of the battery

Preparatory work

(All EXC models)

- Press and hold the kill switch ☒ while the engine is idling until the engine stops.

(All XC-W models)

- Press and hold the kill switch ☒ while the engine is idling until the engine stops.

- Remove the seat. (📖 p. 121)

Main work

- Disconnect negative cable ❶ of the battery.

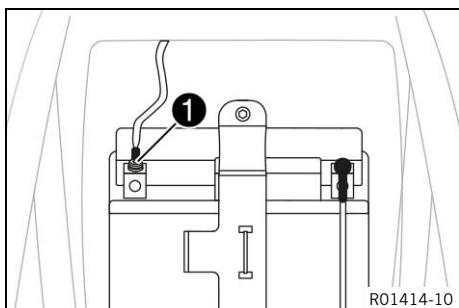

15.5 Connecting the negative cable of the battery

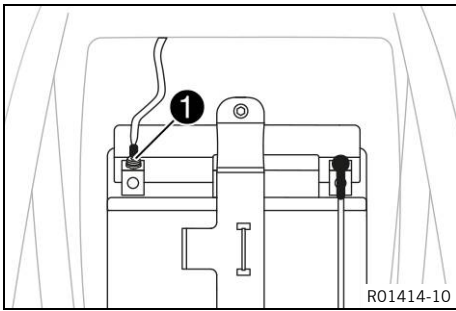

Main work

- Connect negative cable ① of the battery.

Guideline

Screw, battery terminal	M5	2.5 Nm (1.84 lbf ft)
-------------------------	----	-------------------------

Finishing work

- Mount the seat. (📖 p. 121)



15.6 Removing the battery



Note

Environmental hazard Batteries contain environmentally-hazardous materials.

- Do not dispose of batteries as household waste.
- Dispose of batteries at a collection point for used batteries.



Note

Environmental hazard Hazardous substances cause environmental damage.

- Dispose of oils, grease, filters, fuel, cleaning agents, brake fluid, etc., correctly and in compliance with the applicable regulations.

Preparatory work

(All EXC models)

- Press and hold the kill switch ☒ while the engine is idling until the engine stops.

(All XC-W models)

- Press and hold the kill switch ☒ while the engine is idling until the engine stops.
- Remove the seat. (📖 p. 121)

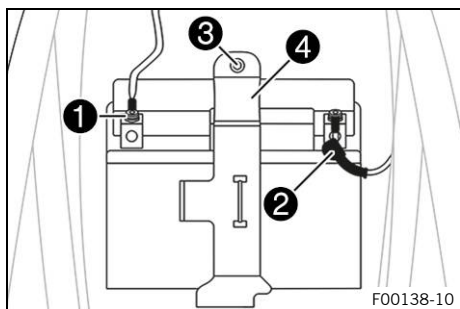

Main work



Warning

Risk of injury Batteries contain harmful substances.

- Keep batteries out of the reach of children.
- Keep sparks and open flames away from the batteries.
- Only charge batteries in well-ventilated rooms.
- Maintain a minimum clearance from inflammable materials when charging batteries.
Minimum clearance 1 m (3 ft)
- Do not charge deeply discharged batteries if charge is already below the minimum voltage.
Minimum voltage before the start of the charge 9 V
- Dispose of batteries with less than the minimum voltage correctly.

- Disconnect negative cable ① from the battery.
- Pull back positive terminal cover ② and disconnect the positive cable from the battery.
- Remove screw ③.
- Pull holding bracket ④ forward and remove battery toward the top.

15.7 Installing the battery

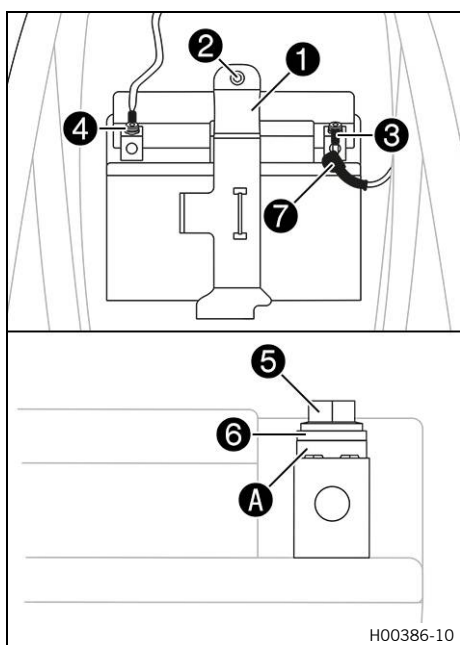

Main work

- Insert the battery into the battery compartment with the terminals facing forward and secure with holding bracket ①.

Battery (HJTZ5S-FP) (📖 p. 317)

- Mount and tighten screw ②.

Guideline

Remaining screws, chassis	M6	10 Nm (7.4 lbf ft)
---------------------------	----	--------------------

- Connect positive cable ③ to the battery.

Guideline

Screw, battery terminal	M5	2.5 Nm (1.84 lbf ft)
-------------------------	----	----------------------

Contact disks **A** must be mounted under the screw ⑤ and the cable lug ⑥ with the claws toward the battery terminal.

- Slide positive terminal cover ⑦ over the positive terminal.
- Connect negative cable ④ to the battery.

Guideline

Screw, battery terminal	M5	2.5 Nm (1.84 lbf ft)
-------------------------	----	----------------------

Contact disks **A** must be mounted under the screw **5** and the cable lug **6** with the claws toward the battery terminal.

Finishing work

- Mount the seat. (📖 p. 121)



15.8 Recharging the battery



Warning

Risk of injury Batteries contain harmful substances.

- Keep batteries out of the reach of children.
- Keep sparks and open flames away from the batteries.
- Only charge batteries in well-ventilated rooms.
- Maintain a minimum clearance from inflammable materials when charging batteries.
Minimum clearance 1 m (3 ft)
- Do not charge deeply discharged batteries if charge is already below the minimum voltage.
Minimum voltage before the start of the charge 9 V
- Dispose of batteries with less than the minimum voltage correctly.



Note

Environmental hazard Batteries contain environmentally-hazardous materials.

- Do not dispose of batteries as household waste.
- Dispose of batteries at a collection point for used batteries.



Note

Environmental hazard Hazardous substances cause environmental damage.

- Dispose of oils, grease, filters, fuel, cleaning agents, brake fluid, etc., correctly and in compliance with the applicable regulations.



Info

Even when there is no load on the battery, it discharges steadily.

The charging level and the method of charging are very important for the service life of the battery.

Rapid recharging with a high charging current shortens the service life of the battery.

If the charging current, charging voltage, or charging time are exceeded, the battery will be destroyed.

If the battery is depleted by repeated starting, the battery must be charged immediately.

If the battery is left in a discharged state for an extended period, it will become over-discharged and sulfated, destroying the battery.

The battery is maintenance-free.

Preparatory work

(All EXC models)

- Press and hold the kill switch  while the engine is idling until the engine stops.

(All XC-W models)

- Press and hold the kill switch  while the engine is idling until the engine stops.
- Remove the seat. (📖 p. 121)
- Disconnect the negative cable of the battery. (📖 p. 160)

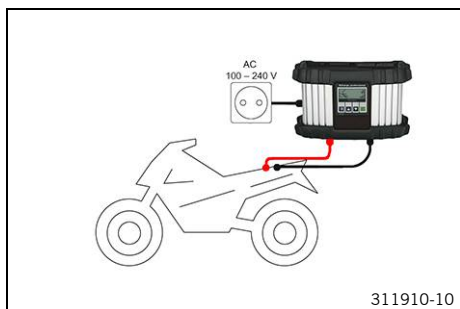

Main work

- Connect the battery charger to the battery. Adjust the battery charger.

EU battery charger **XCharge-professional** (00029095050)
(📖 p. 362)

Alternative 1

US battery charger **XCharge-professional**
(00029095051) (📖 p. 363)

Alternative 2

UK battery charger **XCharge-professional**
(00029095052) (📖 p. 363)

Alternative 3

CH battery charger **XCharge-professional**
(00029095053) (📖 p. 363)

Info

Follow the instructions of the charger and the manual.

- Disconnect the battery charger after charging the battery.

Guideline

The charging current, charging voltage, and charging time must not be exceeded.

Charge the battery regularly when the motorcycle is not in use	3 months
--	----------

Finishing work

- Connect the negative cable of the battery. (📖 p. 161)
- Mount the seat. (📖 p. 121)

15.9 Checking the charging voltage

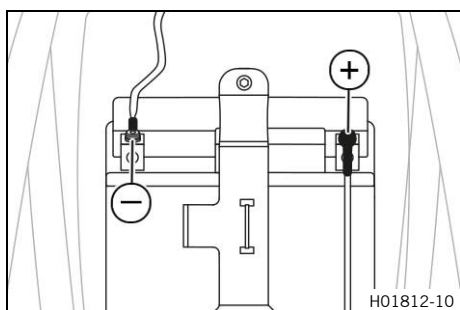

Condition

The battery must be fully functional and completely charged.

- Carry out the start procedure. (📖 p. 12)
- **V** Measure the voltage between the specified points.
Measuring point **plus (+)** – Measuring point **Ground (-)**

Charging voltage

5,000 rpm	13.5 ... 15.0 V
-----------	-----------------

- » If the displayed value is greater than the specified value:
 - Change the voltage regulator.

15.10 Checking the open-circuit current

Preparatory work

(All EXC models)

- Press and hold the kill switch ☒ while the engine is idling until the engine stops.

(All XC-W models)

- Press and hold the kill switch ☒ while the engine is idling until the engine stops.
- Remove the seat. (📖 p. 121)

Main work

- Disconnect the negative cable of the battery.
- Measure the current between battery ground (–) and the negative cable.

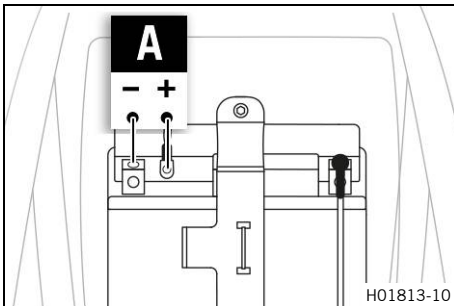

Info

The value of the open-circuit current only applies to vehicles in their original state without additional power consumers.

Maximum open-circuit current	< 1.0 mA
------------------------------	----------

- » If the measured value is greater than the specified value:
 - Disconnect the voltage regulator from the wiring harness and perform the measurement again.



15.11 Checking the starter relay

Preparatory work

(All EXC models)

- Press and hold the kill switch ☒ while the engine is idling until the engine stops.

(All XC-W models)

- Press and hold the kill switch ☒ while the engine is idling until the engine stops.
- Remove the seat. (📖 p. 121)
- Remove the air filter box cover. (📖 p. 116)

Main work

- Disconnect the negative cable of the battery.
- Pull the starter relay off of the bracket.
- Unplug connector ①.
- Disconnect cables ② and ③ on the starter relay.

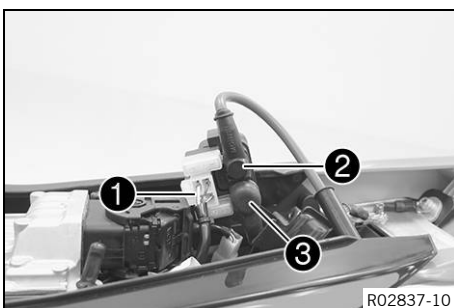

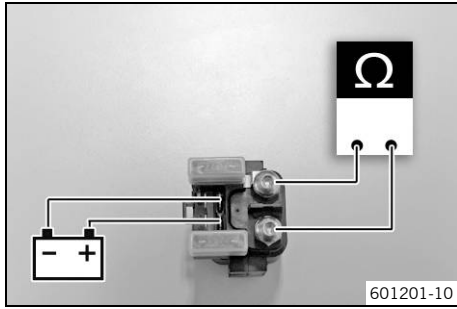

- Connect the starter relay to a 12 V power supply as per the figure.
- Measure the resistance between the specified points.

Resistance of open circuit	0 Ω
----------------------------	-----

- » If the value displayed does not meet specifications:
 - Change the starter relay.

15.12 Diagnostics connector

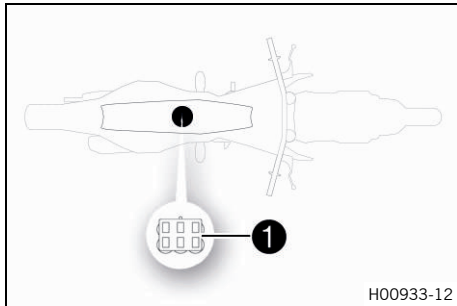

Diagnostics connector **1** is located under the seat.

16.1 Checking the front brake linings



Warning

Danger of accidents Worn-out brake linings reduce the braking effect.

- Ensure that worn-out brake linings are replaced immediately.

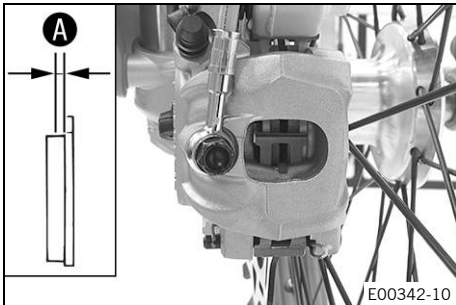

- Check the brake linings for minimum thickness **A**.

Minimum thickness A	$\geq 1 \text{ mm } (\geq 0.04 \text{ in})$
----------------------------	---

- » If the minimum thickness is less than specified:
 - Change the front brake linings. (🔧 p. 167)
- Check the brake linings for damage and cracking.
 - » If damage or wear is encountered:
 - Change the front brake linings. (🔧 p. 167)

16.2 Changing the front brake linings



Warning

Danger of accidents Incorrect maintenance will cause the brake system to fail.

- Ensure that service work and repairs are performed professionally.



Warning

Skin irritation Brake fluid causes skin irritation.

- Keep brake fluid out of the reach of children.
- Wear suitable protective clothing and safety glasses.
- Do not allow brake fluid to come into contact with the skin, the eyes or clothing.
- Consult a doctor immediately if brake fluid has been swallowed.
- Rinse the affected area with plenty of water in the event of contact with the skin.
- Rinse eyes thoroughly with water immediately and consult a doctor if brake fluid comes into contact with the eyes.
- If brake fluid spills on to your clothing, change the clothing.



Warning

Danger of accidents Old brake fluid reduces the braking effect.

- Make sure that brake fluid for the front and rear brake is changed in accordance with the service schedule.



Warning

Danger of accidents Oil or grease on the brake discs reduces the braking effect.

- Always keep the brake discs free of oil and grease.
- Clean the brake discs with brake cleaner when necessary.



Warning

Danger of accidents Brake linings which have not been approved alter the braking efficiency.

Not all brake linings are tested and approved for KTM motorcycles. The structure and friction coefficient of the brake linings, and thus their brake power, may vary greatly from that of original brake linings. If brake linings are used that differ from the original equipment, compliance with the original homologation is not guaranteed. In this case, the vehicle no longer corresponds to its condition at delivery and the warranty shall be void.

- Only use brake linings approved and recommended by KTM.



Note

Environmental hazard Hazardous substances cause environmental damage.

- Dispose of oils, grease, filters, fuel, cleaning agents, brake fluid, etc., correctly and in compliance with the applicable regulations.



Info

Never use DOT 5 brake fluid. It is silicone-based and purple in color. Oil seals and brake lines are not designed for DOT 5 brake fluid.

Avoid contact between brake fluid and painted parts. Brake fluid attacks paint.

Only use clean brake fluid from a sealed container.

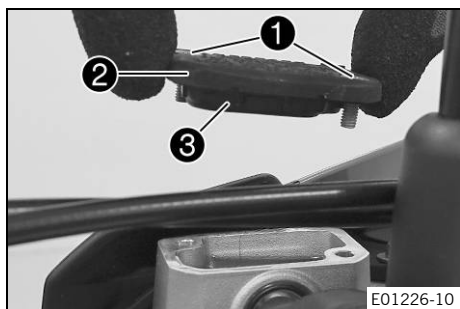

- Move the brake fluid reservoir mounted on the handlebar to a horizontal position.
- Remove screws ①.
- Take off cover ② with membrane ③.
- Manually press the brake caliper toward the brake disc to push back the brake pistons. Ensure that brake fluid does not flow out of the brake fluid reservoir, if necessary extract excess.



Info

Make sure that you do not press the brake caliper against the spokes when pushing back the brake pistons.

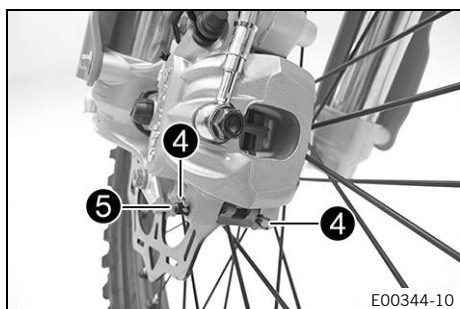

- Remove cotter pin ④, pull out pin ⑤, and remove the brake linings.
- Clean the brake caliper and brake caliper support.

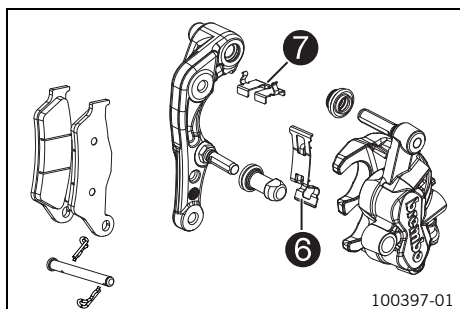

- Check that leaf spring ⑥ in the brake caliper and sliding plate ⑦ in the brake caliper support are seated correctly.

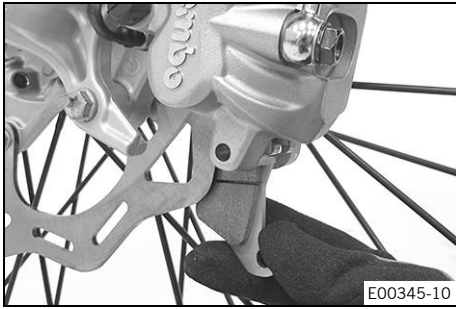

- Insert the new brake linings, insert the pin, and mount the cotter pins.

i Info
Always change the brake linings in pairs.

- Operate the hand brake lever repeatedly until the brake linings are in contact with the brake disc and there is a pressure point.

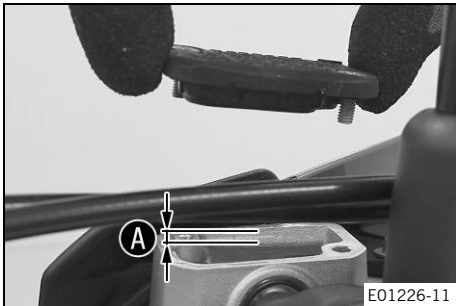

- Correct the brake fluid quantity to level **A**.

Guideline

Level A (brake fluid level below reservoir rim)	5 mm (0.2 in)
--	---------------

Brake fluid DOT 4 / DOT 5.1 (📖 p. 358)

- Position cover with membrane. Mount and tighten the screws.

i Info
Clean up overflowed or spilled brake fluid immediately with water.

16.3 Checking the free travel of the hand brake lever



Warning

Danger of accidents The brake system fails in the event of overheating.

If there is no free travel on the hand brake lever, pressure builds up on the front brake circuit.

- Set the free travel on the hand brake lever in accordance with the specification.

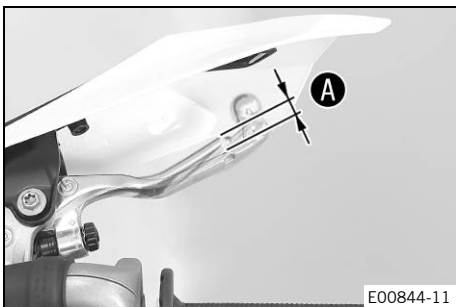

(All EXC models)

- Push the hand brake lever to the handlebar and check free travel **A**.

Free travel of hand brake lever	$\geq 3 \text{ mm } (\geq 0.12 \text{ in})$
---------------------------------	---

- » If the free travel does not match the specification:
 - Adjust the free travel of the hand brake lever. (📖 p. 170)

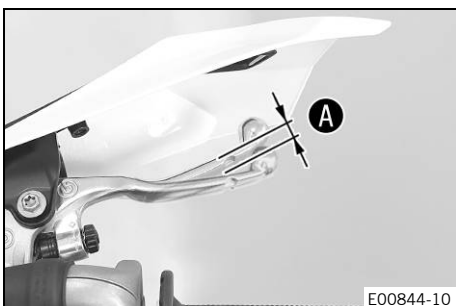

(All XC-W models)

- Push the hand brake lever forward and check free travel **A**.

Free travel of hand brake lever	$\geq 3 \text{ mm } (\geq 0.12 \text{ in})$
---------------------------------	---

- » If the free travel does not match the specification:
 - Adjust the basic position of the hand brake lever. (📖 p. 170)

16.4 Adjusting free travel of hand brake lever (All EXC models)

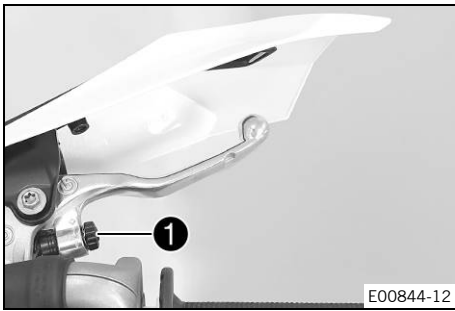

- Check the free travel of the hand brake lever. (📖 p. 169)
- Adjust the free travel of the hand brake lever with the adjustment screw ①.

i Info

Turn the adjusting screw clockwise to reduce free travel. The pressure point moves away from the handlebar.
Turn the adjusting screw counterclockwise to increase free travel. The pressure point moves towards the handlebar.
The range of adjustment is limited.
Turn the adjusting screw by hand only, and do not apply any force.
Do not make any adjustments while riding!

16.5 Adjusting the basic position of the hand brake lever (All XC-W models)

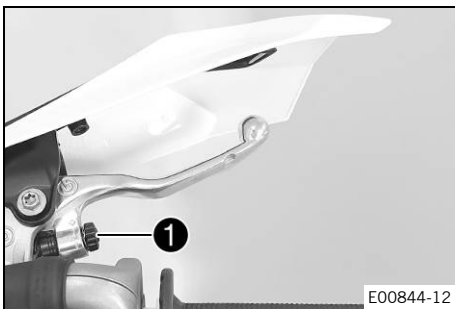

- Check the free travel of the hand brake lever. (📖 p. 169)
- Adjust the basic setting of the hand brake lever to your hand size by turning adjusting screw ①.

i Info

Turn the adjusting screw clockwise to increase the distance between the hand brake lever and the handlebar.
Turn the adjusting screw counterclockwise to decrease the distance between the hand brake lever and the handlebar.
The range of adjustment is limited.
Turn the adjusting screw by hand only, and do not apply any force.
Do not make any adjustments while riding!

16.6 Checking the front brake fluid level



Warning

Danger of accidents An insufficient brake fluid level will cause the brake system to fail.

If the brake fluid level drops below the specified marking or the specified value, the brake system is leaking or the brake linings are worn down.

- Check the brake system and do not continue riding until the problem is eliminated.



Warning

Danger of accidents Old brake fluid reduces the braking effect.

- Make sure that brake fluid for the front and rear brake is changed in accordance with the service schedule.

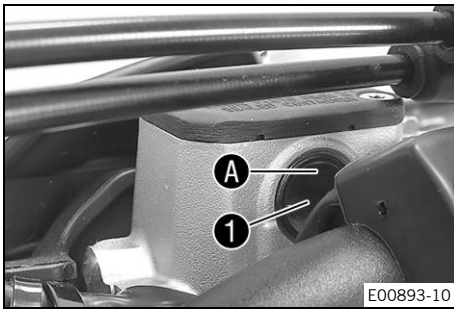

- Move the brake fluid reservoir mounted on the handlebar to a horizontal position.
- Check the brake fluid level in level viewer ①.
 - » If an air bubble is visible in upper range of the level viewer A:
 - Add front brake fluid. (📖 p. 171)



16.7 Adding front brake fluid



Warning

Danger of accidents An insufficient brake fluid level will cause the brake system to fail.

If the brake fluid level drops below the specified marking or the specified value, the brake system is leaking or the brake linings are worn down.

- Check the brake system and do not continue riding until the problem is eliminated.



Warning

Skin irritation Brake fluid causes skin irritation.

- Keep brake fluid out of the reach of children.
- Wear suitable protective clothing and safety glasses.
- Do not allow brake fluid to come into contact with the skin, the eyes or clothing.
- Consult a doctor immediately if brake fluid has been swallowed.
- Rinse the affected area with plenty of water in the event of contact with the skin.
- Rinse eyes thoroughly with water immediately and consult a doctor if brake fluid comes into contact with the eyes.
- If brake fluid spills on to your clothing, change the clothing.



Warning

Danger of accidents Old brake fluid reduces the braking effect.

- Make sure that brake fluid for the front and rear brake is changed in accordance with the service schedule.



Note

Environmental hazard Hazardous substances cause environmental damage.

- Dispose of oils, grease, filters, fuel, cleaning agents, brake fluid, etc., correctly and in compliance with the applicable regulations.



Info

Never use DOT 5 brake fluid. It is silicone-based and purple in color. Oil seals and brake lines are not designed for DOT 5 brake fluid.

Avoid contact between brake fluid and painted parts. Brake fluid attacks paint.

Only use clean brake fluid from a sealed container.

Preparatory work

- Check the front brake linings. (📖 p. 167)

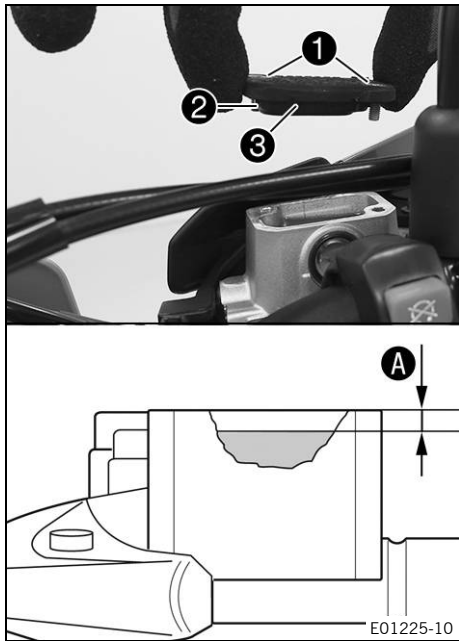

Main work

- Move the brake fluid reservoir mounted on the handlebar to a horizontal position.
- Remove screws ①.
- Take off cover ② with membrane ③.
- Add brake fluid to level A.

Guideline

Level A (brake fluid level below reservoir rim)	5 mm (0.2 in)
---	---------------

Brake fluid DOT 4 / DOT 5.1 (見 p. 358)
--

- Position the cover with the membrane. Mount and tighten the screws.

Info

Clean up overflowed or spilled brake fluid immediately with water.

16.8 Changing the front brake fluid



Warning

Skin irritation Brake fluid causes skin irritation.

- Keep brake fluid out of the reach of children.
- Wear suitable protective clothing and safety glasses.
- Do not allow brake fluid to come into contact with the skin, the eyes or clothing.
- Consult a doctor immediately if brake fluid has been swallowed.
- Rinse the affected area with plenty of water in the event of contact with the skin.
- Rinse eyes thoroughly with water immediately and consult a doctor if brake fluid comes into contact with the eyes.
- If brake fluid spills on to your clothing, change the clothing.



Note

Environmental hazard Hazardous substances cause environmental damage.

- Dispose of oils, grease, filters, fuel, cleaning agents, brake fluid, etc., correctly and in compliance with the applicable regulations.



Info

Never use DOT 5 brake fluid. It is silicone-based and purple in color. Oil seals and brake lines are not designed for DOT 5 brake fluid.

Avoid contact between brake fluid and painted parts. Brake fluid attacks paint.

Only use clean brake fluid from a sealed container.

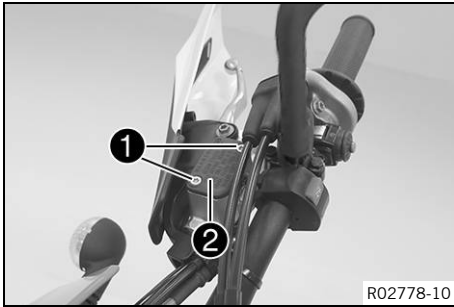

- Move the brake fluid reservoir mounted on the handlebar to a horizontal position.
- Cover painted parts.
- Remove screws ①.
- Take off cover ② with the membrane.
- Extract the old brake fluid out of the brake fluid reservoir using a syringe and fill with fresh brake fluid.

Syringe (50329050000) (📖 p. 364)

Brake fluid DOT 4 / DOT 5.1 (📖 p. 358)
--

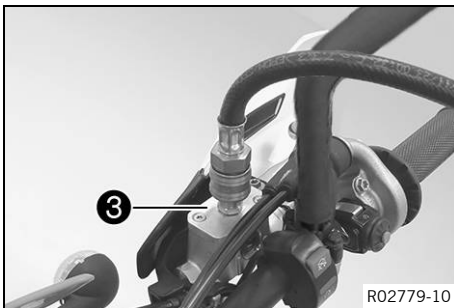

- Mount bleeder cover ③.

Bleeder cover (00029013005) (📖 p. 362)
--

- Connect the bleeding device.

Bleeding device (00029013100) (📖 p. 362)
--

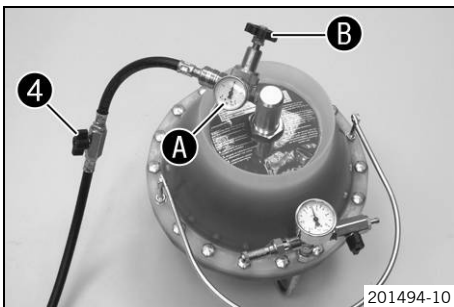

- Open shut-off valve ④.

i Info

Follow the instructions in the Owner's Manual of the bleeding device.

- Ensure that the filling pressure is set on pressure gauge A. Correct the filling pressure on pressure regulator B if necessary.

Guideline

Filling pressure	2 ... 2.5 bar (29 ... 36 psi)
------------------	-------------------------------

- Pull off protection cap ⑤ of the brake caliper bleeder screw. Connect the bleeder bottle hose.

Bleeding device (00029013100) (📖 p. 362)
--

- Open bleeder screw ⑥ by approx. one half turn.

i Info

Drain until fresh brake fluid emerges in the bleeder bottle hose without bubbles.

- Tighten the bleeder screw.
- Close shut-off valve ④.
- Open the bleeder screw again until brake fluid stops emerging.

i Info

Overfilling of the brake fluid reservoir is prevented.

- Tighten the bleeder screw. Remove the bleeder bottle hose. Attach the protection cap.
- Disconnect the bleeding device. Remove the bleeder cover.

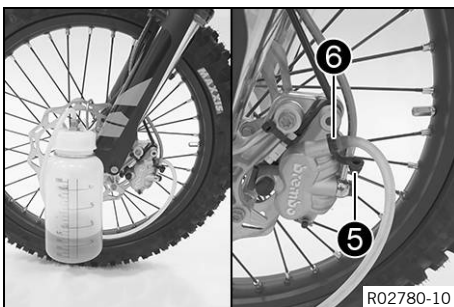

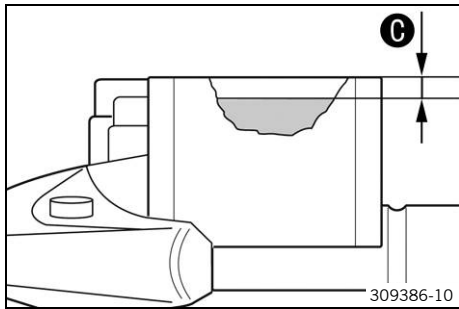

- Add brake fluid up to level **C**.

Guideline

Dimension C	5 mm (0.2 in)
--------------------	---------------

Brake fluid DOT 4 / DOT 5.1 (📖 p. 358)
--

- Position the cover with the membrane. Mount and tighten the screws.



Info

Clean up overflowed or spilled brake fluid immediately with water.

- Check the hand brake lever for a firm pressure point.

16.9 Checking the brake linings of the rear brake



Warning

Danger of accidents Worn-out brake linings reduce the braking effect.

- Ensure that worn-out brake linings are replaced immediately.

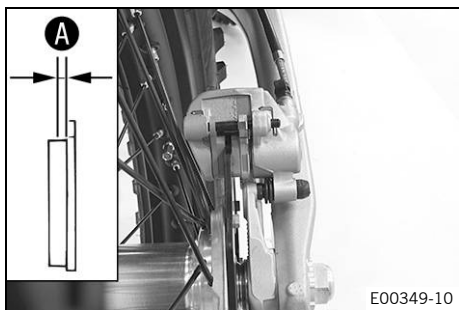

- Check the brake linings for minimum thickness **A**.

Minimum thickness A	$\geq 1 \text{ mm}$ ($\geq 0.04 \text{ in}$)
----------------------------	--

- » If the minimum thickness is less than specified:
 - Change the rear brake linings. (📖 p. 174)
- Check the brake linings for damage and cracking.
 - » If damage or wear is encountered:
 - Change the rear brake linings. (📖 p. 174)

16.10 Changing the rear brake linings



Warning

Danger of accidents Incorrect maintenance will cause the brake system to fail.

- Ensure that service work and repairs are performed professionally.



Warning

Skin irritation Brake fluid causes skin irritation.

- Keep brake fluid out of the reach of children.
- Wear suitable protective clothing and safety glasses.
- Do not allow brake fluid to come into contact with the skin, the eyes or clothing.
- Consult a doctor immediately if brake fluid has been swallowed.
- Rinse the affected area with plenty of water in the event of contact with the skin.
- Rinse eyes thoroughly with water immediately and consult a doctor if brake fluid comes into contact with the eyes.
- If brake fluid spills on to your clothing, change the clothing.

**Warning**

Danger of accidents Old brake fluid reduces the braking effect.

- Make sure that brake fluid for the front and rear brake is changed in accordance with the service schedule.

**Warning**

Danger of accidents Brake linings which have not been approved alter the braking efficiency.

Not all brake linings are tested and approved for KTM motorcycles. The structure and friction coefficient of the brake linings, and thus their brake power, may vary greatly from that of original brake linings. If brake linings are used that differ from the original equipment, compliance with the original homologation is not guaranteed. In this case, the vehicle no longer corresponds to its condition at delivery and the warranty shall be void.

- Only use brake linings approved and recommended by KTM.

**Note**

Environmental hazard Hazardous substances cause environmental damage.

- Dispose of oils, grease, filters, fuel, cleaning agents, brake fluid, etc., correctly and in compliance with the applicable regulations.

**Info**

Never use DOT 5 brake fluid. It is silicone-based and purple in color. Oil seals and brake lines are not designed for DOT 5 brake fluid.

Avoid contact between brake fluid and painted parts. Brake fluid attacks paint.

Only use clean brake fluid from a sealed container.

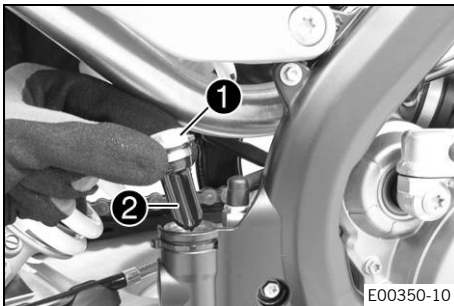

- Stand the vehicle upright.
- Remove screw cap ① with membrane ② and the O-ring.
- Press the brake piston back into the basic position and ensure that brake fluid does not flow out of the brake fluid reservoir; extract some if necessary.

**Info**

Make sure when pushing back the brake piston that you do not press the brake caliper against the spokes.

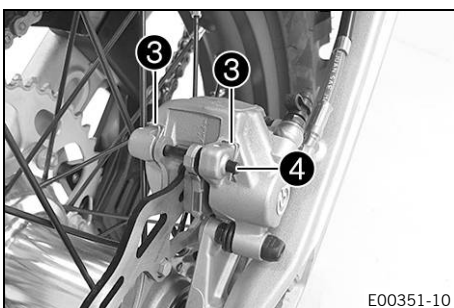

- Remove cotter pin ③, pull out pin ④, and remove the brake linings.
- Clean the brake caliper and brake caliper support.

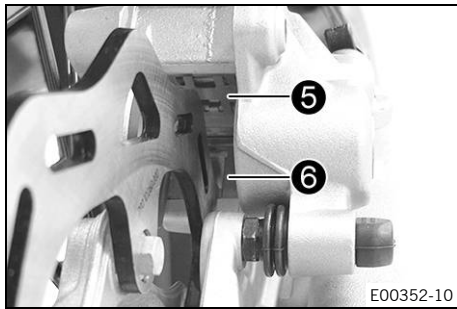

- Check that leaf spring **5** in the brake caliper and sliding plate **6** in the brake caliper support are seated correctly.

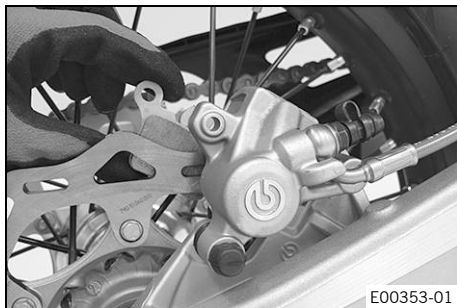

- Insert the new brake linings, insert the pin, and mount the cotter pins.



Info

Always change the brake linings in pairs.

- Operate the foot brake lever repeatedly until the brake linings are in contact with the brake disc and there is a pressure point.

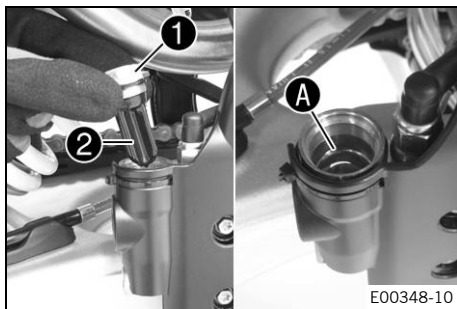

- Add brake fluid to level **A**.

Brake fluid DOT 4 / DOT 5.1 (📖 p. 358)
--

- Mount screw cap **1** with membrane **2** and O-ring.



Info

Clean up overflowed or spilled brake fluid immediately with water.

16.11 Checking the free travel of foot brake lever



Warning

Danger of accidents The brake system fails in the event of overheating.

If there is no free travel on the foot brake lever, pressure builds up in the brake system on the rear brake.

- Set the free travel on the foot brake lever in accordance with the specification.

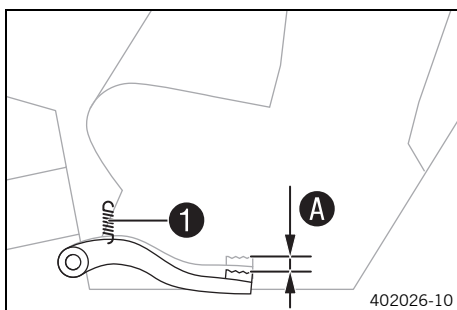

- Disconnect spring **1**.
- Move the foot brake lever back and forth between the end stop and the contact to the foot brake cylinder piston and check free travel **A**.

Guideline

Free travel at foot brake lever	3 ... 5 mm (0.12 ... 0.2 in)
---------------------------------	------------------------------

- » If the free travel does not meet specifications:
 - Adjust the basic position of the foot brake lever. (📖 p. 177)

- Reconnect spring **1**.

16.12 Adjusting the basic position of the foot brake lever



Warning

Danger of accidents The brake system fails in the event of overheating.

If there is no free travel on the foot brake lever, pressure builds up in the brake system on the rear brake.

- Set the free travel on the foot brake lever in accordance with the specification.

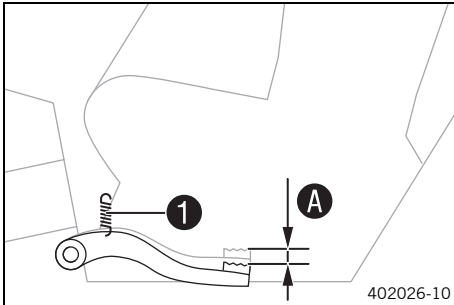

- Disconnect spring **1**.

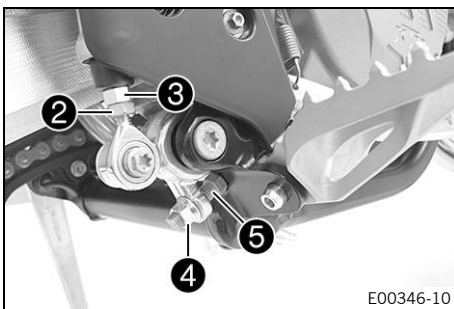

- Loosen nut **2** and, with push rod **3**, turn it back until you have maximum free travel.
- To adjust the basic position of the foot brake lever to individual requirements, loosen nut **4** and turn screw **5** accordingly.



Info

The range of adjustment is limited.

- Turn push rod **3** accordingly until you have free travel **A**. If necessary, adjust the basic position of the foot brake lever.

Guideline

Free travel at foot brake lever	3 ... 5 mm (0.12 ... 0.2 in)
---------------------------------	------------------------------

- Hold screw **5** and tighten nut **4**.

Guideline

Nut, foot brake lever stop	M8	20 Nm (14.8 lbf ft)
----------------------------	----	---------------------

- Hold push rod **3** and tighten nut **2**.

Guideline

Remaining nuts, chassis	M6	10 Nm (7.4 lbf ft)
-------------------------	----	--------------------

- Reconnect spring **1**.



16.13 Checking the rear brake fluid level



Warning

Danger of accidents An insufficient brake fluid level will cause the brake system to fail.

If the brake fluid level drops below the specified marking or the specified value, the brake system is leaking or the brake linings are worn down.

- Check the brake system and do not continue riding until the problem is eliminated.



Warning

Danger of accidents Old brake fluid reduces the braking effect.

- Make sure that brake fluid for the front and rear brake is changed in accordance with the service schedule.

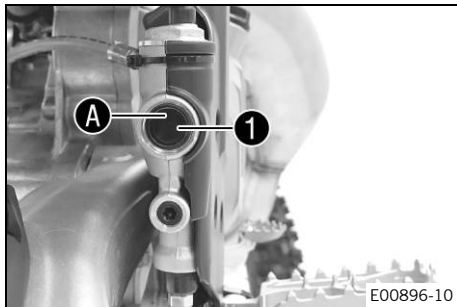

- Stand the vehicle upright.
- Check the brake fluid level in the viewer **1**.
 - » If the fluid has dropped below marking **A** in the level viewer:
 - Add rear brake fluid. (🗨️ p. 178)

16.14 Adding rear brake fluid



Warning

Danger of accidents An insufficient brake fluid level will cause the brake system to fail.

If the brake fluid level drops below the specified marking or the specified value, the brake system is leaking or the brake linings are worn down.

- Check the brake system and do not continue riding until the problem is eliminated.



Warning

Skin irritation Brake fluid causes skin irritation.

- Keep brake fluid out of the reach of children.
- Wear suitable protective clothing and safety glasses.
- Do not allow brake fluid to come into contact with the skin, the eyes or clothing.
- Consult a doctor immediately if brake fluid has been swallowed.
- Rinse the affected area with plenty of water in the event of contact with the skin.
- Rinse eyes thoroughly with water immediately and consult a doctor if brake fluid comes into contact with the eyes.
- If brake fluid spills on to your clothing, change the clothing.



Warning

Danger of accidents Old brake fluid reduces the braking effect.

- Make sure that brake fluid for the front and rear brake is changed in accordance with the service schedule.

**Note**

Environmental hazard Hazardous substances cause environmental damage.

- Dispose of oils, grease, filters, fuel, cleaning agents, brake fluid, etc., correctly and in compliance with the applicable regulations.

**Info**

Never use DOT 5 brake fluid. It is silicone-based and purple in color. Oil seals and brake lines are not designed for DOT 5 brake fluid.

Avoid contact between brake fluid and painted parts. Brake fluid attacks paint.

Only use clean brake fluid from a sealed container.

Preparatory work

- Check the brake linings of the rear brake. (📖 p. 174)

Main work

- Stand the vehicle upright.
- Remove screw cap ① with membrane ② and the O-ring.
- Add brake fluid to level A.

Brake fluid DOT 4 / DOT 5.1 (📖 p. 358)

- Mount and tighten the screw cap with the membrane and O-ring.

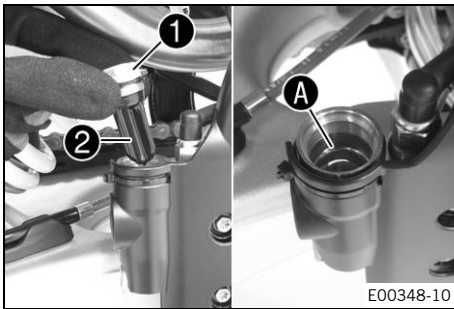
**Info**

Clean up overflowed or spilled brake fluid immediately with water.

16.15 Changing the rear brake fluid

**Warning**

Skin irritation Brake fluid causes skin irritation.

- Keep brake fluid out of the reach of children.
- Wear suitable protective clothing and safety glasses.
- Do not allow brake fluid to come into contact with the skin, the eyes or clothing.
- Consult a doctor immediately if brake fluid has been swallowed.
- Rinse the affected area with plenty of water in the event of contact with the skin.
- Rinse eyes thoroughly with water immediately and consult a doctor if brake fluid comes into contact with the eyes.
- If brake fluid spills on to your clothing, change the clothing.

**Note**

Environmental hazard Hazardous substances cause environmental damage.

- Dispose of oils, grease, filters, fuel, cleaning agents, brake fluid, etc., correctly and in compliance with the applicable regulations.

**Info**

Never use DOT 5 brake fluid. It is silicone-based and purple in color. Oil seals and brake lines are not designed for DOT 5 brake fluid.

Avoid contact between brake fluid and painted parts. Brake fluid attacks paint.

Only use clean brake fluid from a sealed container.

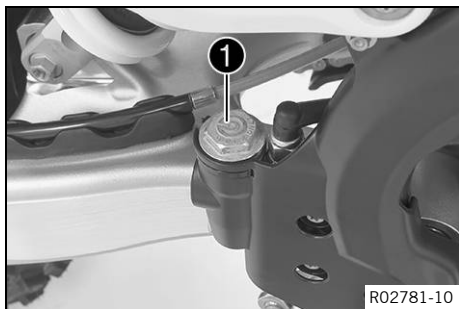

- Cover painted parts.
- Remove screw cap 1 with the membrane and the O-ring.
- Extract the old brake fluid out of the brake fluid reservoir using a syringe and fill with fresh brake fluid.

Syringe (50329050000) (🗨️ p. 364)

Brake fluid DOT 4 / DOT 5.1 (🗨️ p. 358)

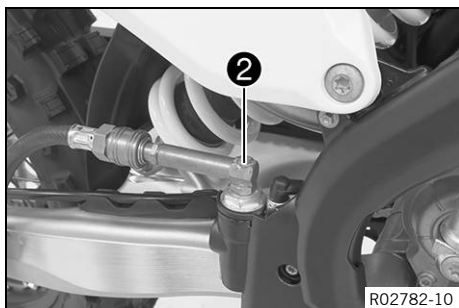

- Mount bleeder cover 2.

Bleeder cover (00029013006) (🗨️ p. 362)

- Connect the bleeding device.

Bleeding device (00029013100) (🗨️ p. 362)

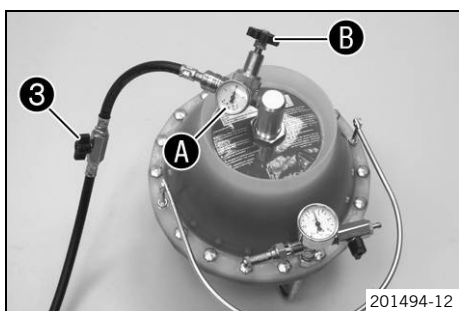

- Open shut-off valve 3.

i Info

Follow the instructions in the Owner's Manual of the bleeding device.

- Ensure that the filling pressure is set on pressure gauge A. Correct the filling pressure on pressure regulator B if necessary.

Guideline

Filling pressure	2 ... 2.5 bar (29 ... 36 psi)
------------------	-------------------------------

- Pull off protection cap 4 of the bleeder screw. Connect the bleeder bottle hose.

Bleeding device (00029013100) (🗨️ p. 362)

- Open bleeder screw 5 by approx. one half turn.

i Info

Drain until fresh brake fluid emerges in the bleeder bottle hose without bubbles.

- Tighten the bleeder screw.
- Close shut-off valve 3.
- Open the bleeder screw again until brake fluid stops emerging.

i Info

Overfilling of the brake fluid reservoir is prevented.

- Tighten the bleeder screw. Remove the bleeder bottle hose. Attach the protection cap.
- Disconnect the bleeding device. Remove the bleeder cover.

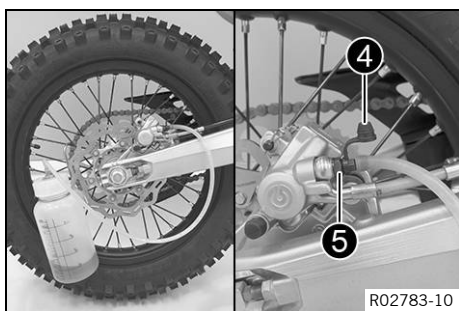

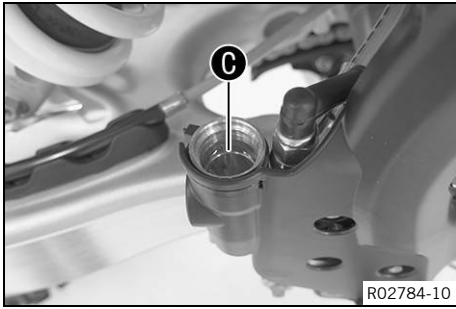

- Stand the vehicle upright.
- Correct the brake fluid to marking **C**.

Brake fluid DOT 4 / DOT 5.1 (📖 p. 358)

- Mount and tighten the screw cap with the membrane and O-ring.

**Info**

Clean up overflowed or spilled brake fluid immediately with water.

- Check the foot brake lever for a firm pressure point.



17.1 Changing the headlight bulb

Note

Damage to reflector Grease on the reflector reduces the brightness.

Grease on the bulb will evaporate due to the heat and be deposited on the reflector.

- Clean and degrease the bulbs before mounting.
- Do not touch the bulbs with your bare hands.

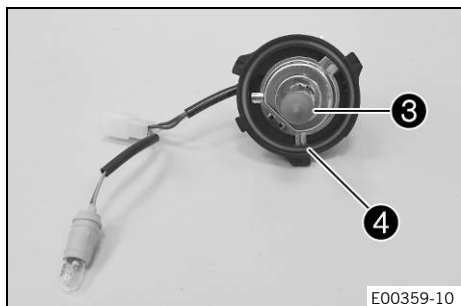
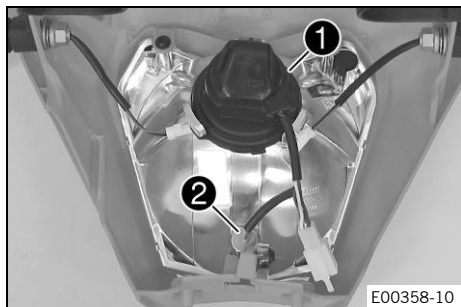

Preparatory work

- Remove the headlight mask with the headlight. (📖 p. 135)

Main work

- Turn protection cap ① together with the underlying bulb socket counterclockwise all the way and remove it.
- Pull bulb socket ② of the position light out of the reflector.

- Pull out headlight bulb ③.

- Insert the new headlight bulb.

Headlight (HS1/socket BX43t) (📖 p. 317)

- Insert the protection cap with the bulb socket into the reflector and turn it clockwise all the way.

Info

Ensure that O-ring ④ is seated properly.

- Insert the bulb socket of the position light into the reflector.

Finishing work

- Install the headlight mask with the headlight. (📖 p. 135)
- Check the headlight setting. (📖 p. 183)

17.2 Changing the turn signal bulb (All EXC models)

Note

Damage to reflector Grease on the reflector reduces the brightness.

Grease on the bulb will evaporate due to the heat and be deposited on the reflector.

- Clean and degrease the bulbs before mounting.
- Do not touch the bulbs with your bare hands.

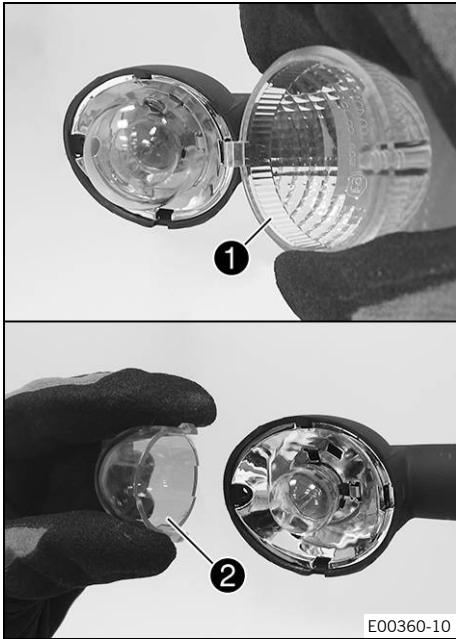

Main work

- Remove the screw on the rear of the turn signal housing.
- Carefully remove turn signal glass **1**.
- Lightly squeeze orange cap **2** in the area of the holding lugs and take it off.
- Press the turn signal bulb lightly into the socket, turn it counterclockwise by about 30°, and take it out of the socket.

Info

Do not touch the reflector with your fingers and keep it free from grease.

- Press the new turn signal bulb carefully into the socket and turn it clockwise until it stops.

Turn signal (R10W / socket BA15s) (📖 p. 317)
--

- Mount the orange cap.
- Position the turn signal glass.
- Insert the screw and first turn counterclockwise until it engages in the thread with a small jerk. Tighten the screw lightly.

Finishing work

- Check that the turn signal system is functioning properly.

17.3 Checking the headlight setting

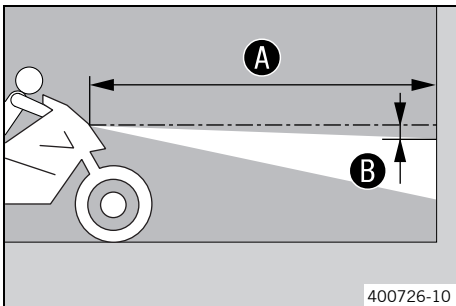

- Position the vehicle upright on a horizontal surface in front of a light wall and make a marking at the height of the center of the low beam headlight.

- Make another mark at a distance **B** under the first marking.

Guideline

Distance B	5 cm (2 in)
-------------------	-------------

- Position the vehicle vertically at a distance **A** away from the wall.

Guideline

Distance A	5 m (16 ft)
-------------------	-------------

- The rider now sits down on the motorcycle.
- Switch on the low beam.
- Check the headlight setting.

The boundary between light and dark must be exactly on the lower mark for a motorcycle with rider.
--

- » If the light-dark border does not meet specifications:
 - Adjust the headlight range. (📖 p. 184)

17.4 Adjusting the headlight range

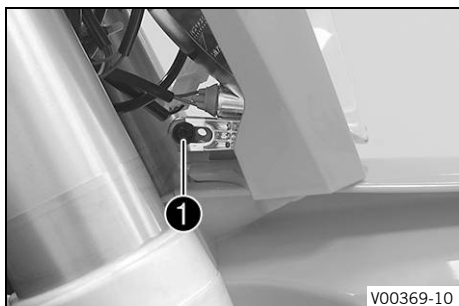

V00369-10

Preparatory work

- Check the headlight setting. (📖 p. 183)

Main work

- Loosen screw ①.
- Adjust the headlight range by pivoting the headlight.

Guideline

The boundary between light and dark must be exactly on the lower marking for a motorcycle with rider (instructions on how to apply the marking: Checking the headlight setting).



Info

If you have a payload, you may have to correct the headlight range.

- Tighten screw ①.

17.5 Changing the combination instrument

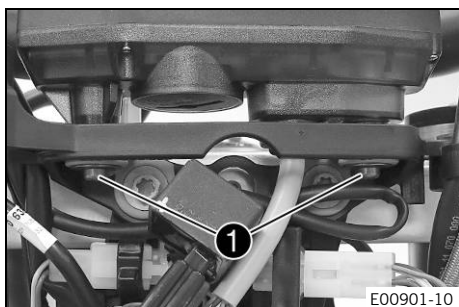

E00901-10

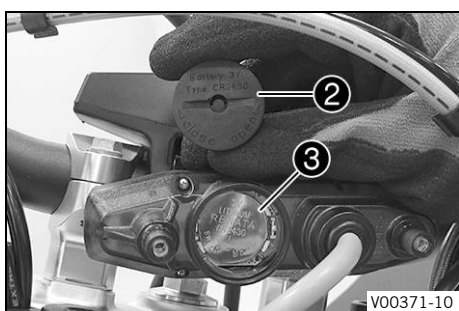

V00371-10

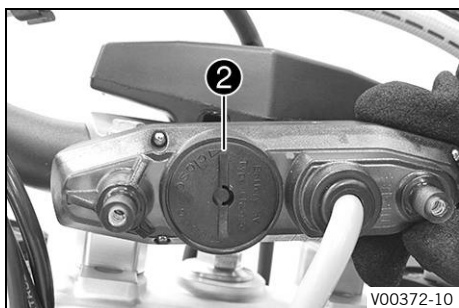

V00372-10

Preparatory work

- Remove the headlight mask with the headlight. (📖 p. 135)

Main work

- Remove screws ①.
- Pull the combination instrument upward out of the holder.

- Using a coin, turn protection cap ② all the way counterclockwise and remove it.
- Remove combination instrument ③.
- Insert the new battery with the label facing outward.

Combination instrument battery (CR 2430) (📖 p. 317)

- Check the O-ring of the protection cap for correct seating.
- Position protection cap ② and turn all the way clockwise using a coin.
- Press any button on the combination instrument.
 - ✓ The combination instrument is activated.
- Position the combination instrument in the holder.
- Mount and tighten the screws with washers.

Finishing work

- Install the headlight mask with the headlight. (📖 p. 135)
- Check the headlight setting. (📖 p. 183)
- Set kilometers or miles. (📖 p. 185)
- Adjust the combination instrument function. (📖 p. 186)
- Set the clock. (📖 p. 187)



17.6 Combination instrument overview

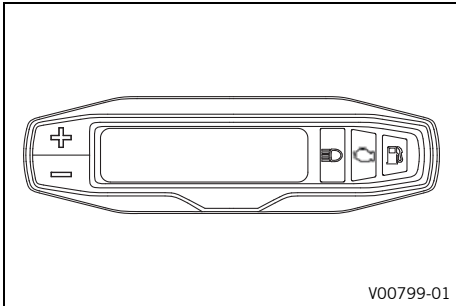

- The button is used to select menus and make settings.
- The button is used to select menus and make settings.

Info

When the vehicle is delivered, only the **SPEED/H** and **SPEED/ODO** display modes are activated.

17.7 Activation and test

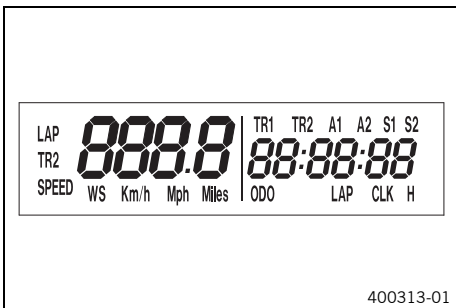

Activating combination instrument

The combination instrument is activated when one of the buttons is pressed or an impulse comes from the wheel speed sensor.

Display test

To enable you to check that the display is functioning properly, all display segments light up briefly.



WS (wheel size)

After the display function check, the wheel circumference **WS** is displayed briefly.

Info

The number 2205 equals the circumference of the 21" front wheel with standard tires.

The display then changes to the last selected mode.

17.8 Setting the kilometers or miles

Info

If you change the unit, the value **ODO** is retained and converted accordingly. The values **TR1**, **TR2**, **A1**, **A2** and **S1** are cleared when the unit of measure is changed.

Condition

The motorcycle is stationary.

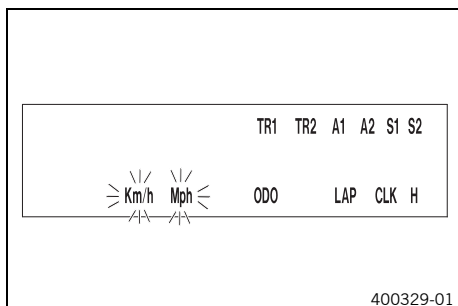

- Repeatedly press the button briefly until **H** appears at the bottom right of the display.
- Press the button for 2–3 seconds.
 - ✓ The Setup menu is displayed and the active functions are shown.
- Repeatedly press the button briefly until **Km/h/Mph** flashes.

Setting the Km/h

- Press the button .

Setting the Mph

- Press the button .
- Wait 3 - 5 seconds.
 - ✓ The settings are stored.



Info

If no button is pressed for 10-12 seconds, or if an impulse comes from the wheel speed sensor, the settings are automatically saved and the setup menu is closed.

17.9 Adjusting the combination instrument function



Info

When the vehicle is delivered, only the **SPEED/H** and **SPEED/ODO** display modes are activated.

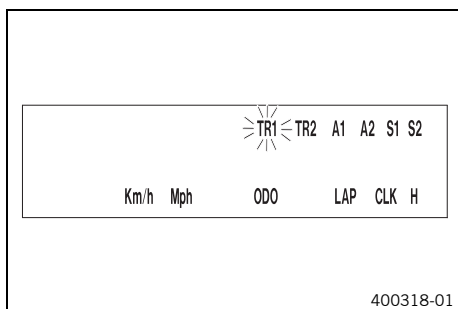

Condition

The motorcycle is stationary.

- Repeatedly press the button briefly until **H** appears at the bottom right of the display.
- Press the button for 2–3 seconds.
 - ✓ The Setup menu is displayed and the active functions are shown.



Info

If no button is pressed for 10 - 12 seconds, the settings are automatically saved.
If no button is pressed for 20 seconds, or if an impulse comes from the wheel speed sensor, the settings are automatically saved and the setup menu is closed.

- Repeatedly press the button briefly until the desired function flashes.
 - ✓ The selected function flashes.

Activating the function

- Press the button .
 - ✓ The symbol continues to appear in the display and the next function appears.

Deactivating a function

- Press the button .
 - ✓ The symbol disappears in the display and the next function appears.

17.10 Setting the clock

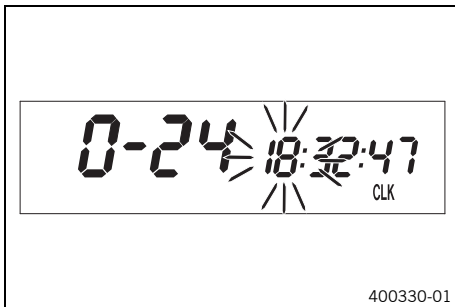

Condition

The motorcycle is stationary.

- Repeatedly press the button **+** briefly until **CLK** appears at the bottom right of the display.
- Press the button **+** for 2-3 seconds.
 - ✓ The hour display flashes.
- Set the hour display with the button **+** and/or button **-**.
- Wait 3 - 5 seconds.
 - ✓ The next segment of the display flashes and can be set.
- You can set the following segments in the same way as the hours by pressing the button **+** and the button **-**.

Info

The seconds can only be set to zero.

If no button is pressed for 15 - 20 seconds, or if an impulse comes from the wheel speed sensor, the settings are automatically saved and the setup menu is closed.



17.11 Activating additional functions



Danger

Voiding of the government approval for road use and the insurance coverage The vehicle is only authorized for operation on public roads in the homologated version.

- If the vehicle is modified in any way, it may only be used on designated tracks away from public roads. Advise the vehicle owner and rider of this.
- If you undertake any modifications, please insist on receiving a signed workshop order from your customer in which you inform the customer in writing that these modifications are performed at the customer's own risk and that the vehicle will no longer be approved for use on public roads once modified.

Preparatory work

- Remove the headlight mask with the headlight. (📖 p. 135)

Main work

- Expose plug-in connector **CZ** ①.

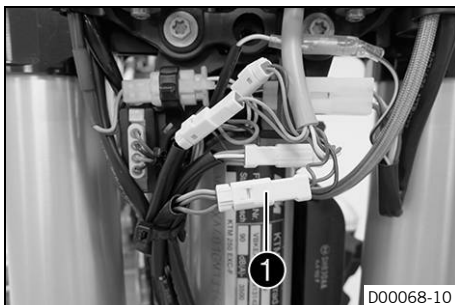

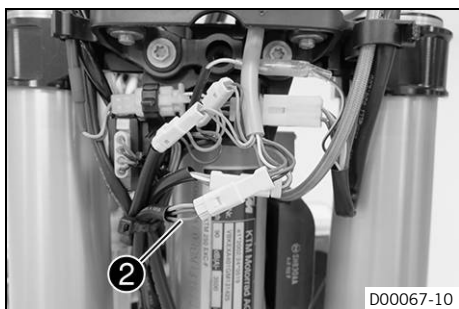

- Sever black/brown cable ②.
- Insulate both cable ends.

Finishing work

- Install the headlight mask with the headlight. (🔧 p. 135)
- Check the headlight setting. (🔧 p. 183)

17.12 Setting the wheel circumference



Condition

The motorcycle is stationary.

Preparatory work

- Remove the headlight mask with the headlight. (🔧 p. 135)
- Activate additional functions. (🔧 p. 187)

Main work

- Repeatedly press the button  briefly until **H** appears at the bottom right of the display.
- Press the button  for 2–3 seconds.
- When **WS** flashes, press the  button briefly.

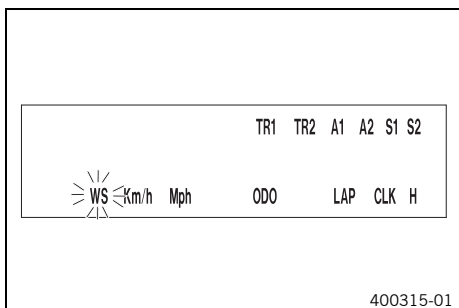

Info

The wheel circumference is displayed in millimeters.

Enlarging the wheel circumference

- Press the button .

Reducing the wheel circumference

- Press the button .

Info

If no button is pressed for 20 seconds, or if no impulse comes from the wheel speed sensor, the settings are automatically saved and the Setup menu is closed.

17.13 Viewing the lap time





Info

This function can only be opened if lap times have actually been timed.

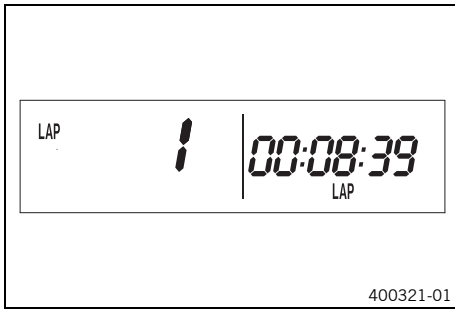
Condition

The motorcycle is stationary.



- Repeatedly press the button  briefly until **LAP** appears at the bottom right of the display.
- Briefly press the button .
 - ✓ **LAP 1** appears on the left side of the display.
- The laps 1 - 10 can be viewed with the button .
- Press and hold the button  for 3 - 5 seconds.
 - ✓ The lap times are deleted.
- Briefly press the button .
 - ✓ Next display mode

 **Info**
 When a signal from the wheel speed sensor arrives, the left side of the display changes back to the **SPEED** mode.

18.1 Cleaning the pressure sensor hose

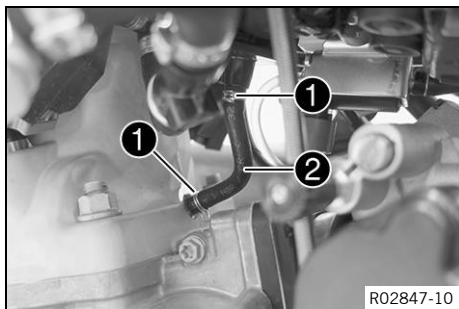

- Push back hose clamps ①.
- Pull off pressure sensor hose ②.

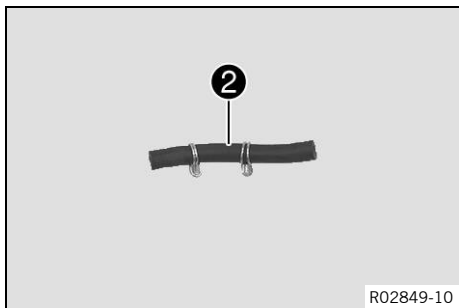

- Clean hose ② thoroughly and blow out with compressed air.

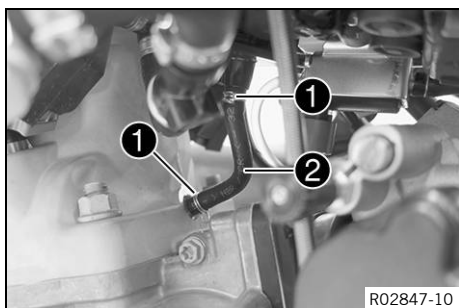

- Mount pressure sensor hose ②.
- Position hose clamps ①.

18.2 Removing the engine

Preparatory work

(All Six Days models)

- Remove the engine guard. (📖 p. 74)
- Raise the motorcycle with a lift stand. (📖 p. 12)

(All EXC models)

- Press and hold the kill switch ☒ while the engine is idling until the engine stops.

(All XC-W models)

- Press and hold the kill switch ☒ while the engine is idling until the engine stops.
- Remove the seat. (📖 p. 121)
- Disconnect the negative cable of the battery. (📖 p. 160)
- Drain the coolant. (📖 p. 287)
- Remove the manifold. (📖 p. 111)
- Remove the air filter box cover. (📖 p. 116)

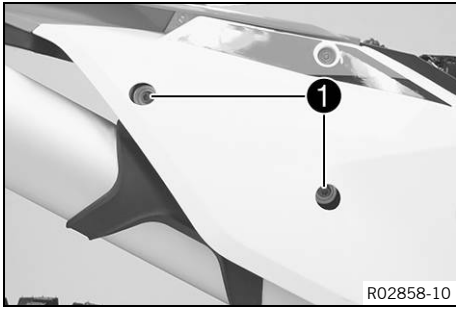

Main work

- Remove screws **1** with the washers.
- Take off the main silencer.

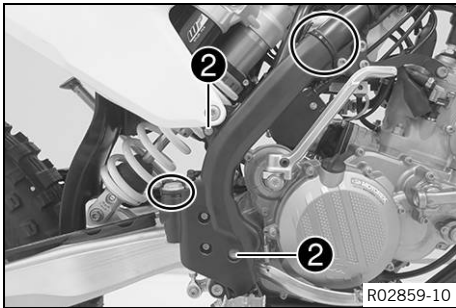

- Remove screws **2** with the washers.
- Remove the cable ties.
- Take off the frame protector.

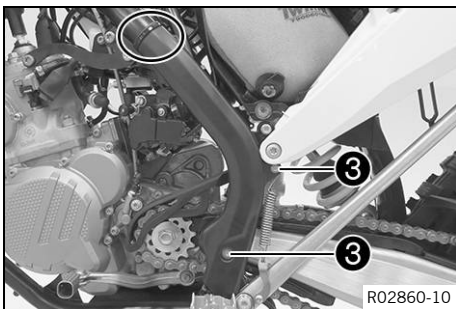

- Remove screws **3** with the washers.
- Remove the cable tie.
- Take off the frame protector.

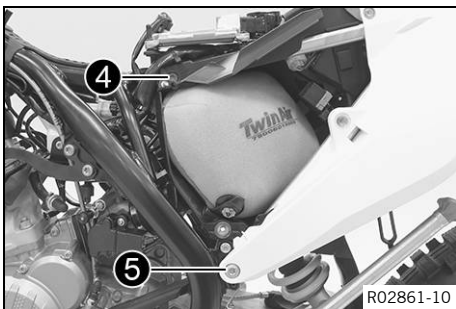

- Loosen screw **4**.
- Remove screw **5**.
- Repeat these steps on the opposite side.

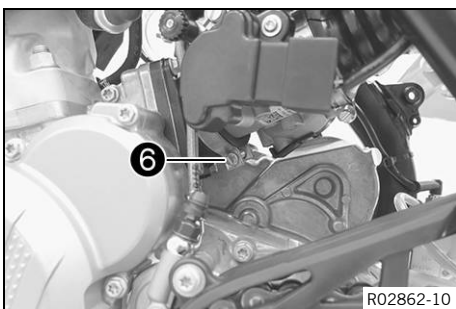

- Remove hose clip **6**.



- Raise the subframe slightly and secure.



Info

Pay attention to the oil pump hose.

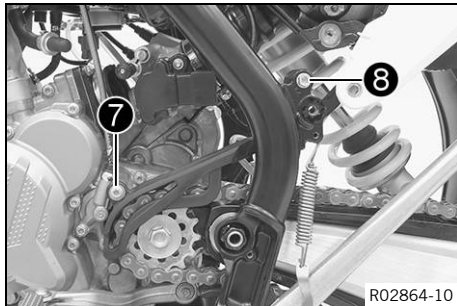

- Remove screw 7.
- Remove screw 8.
- Take off the engine sprocket cover.

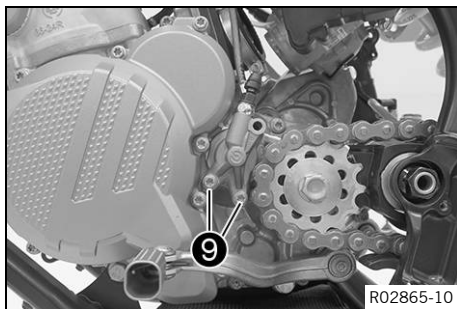

- Remove screws 9.
- Take off the slave cylinder of the clutch and hang it to one side.



Info

Do not kink the clutch line.
Do not activate the clutch lever while the slave cylinder of the clutch is removed.

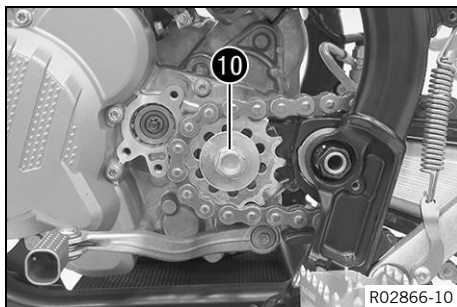

- Have an assistant operate the rear brake.
- Remove screw 10 with the washer.

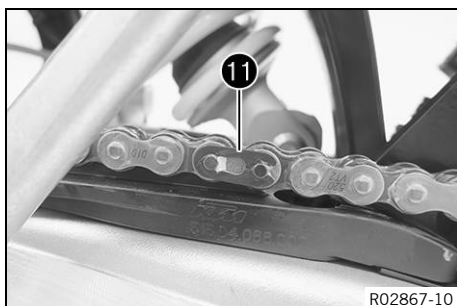

- Remove connecting link 11 of the chain.



Info

Cover the components to protect them against damage.

- Take off the chain.

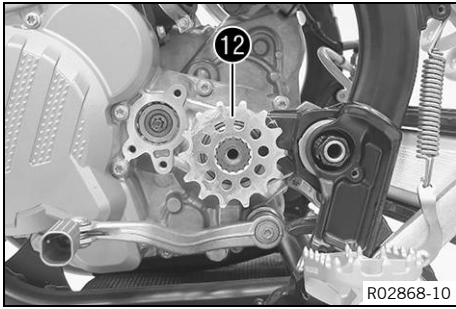

- Remove engine sprocket **12**.

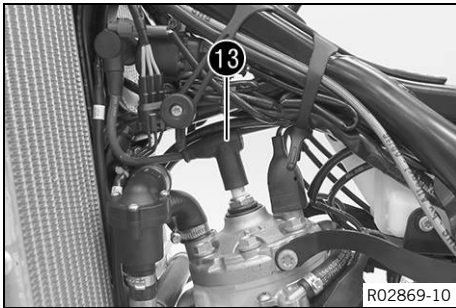

- Disconnect spark plug connector **13**.

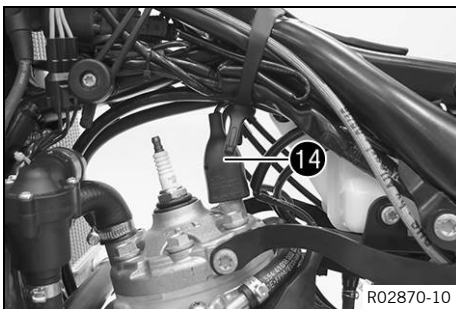

- Push back protection cap **14**.
- Disconnect engine coolant temperature sensor connector.

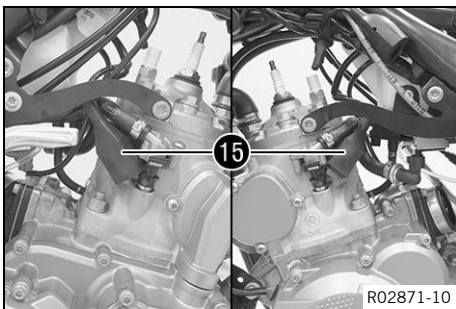

- Push back protection caps **15**.
- Disconnect connector.

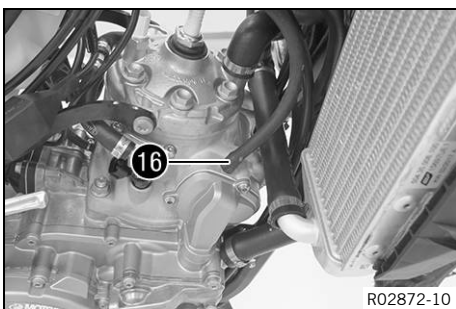

- Pull off air release hose **16**.

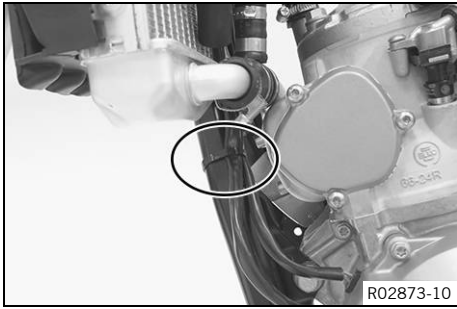

- Remove the cable tie.

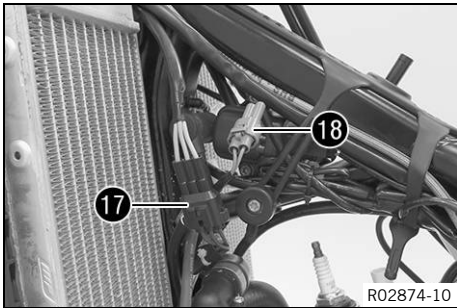

- Disconnect plug-in connector 17.
- Disconnect plug-in connector 18.
- Expose the cable.

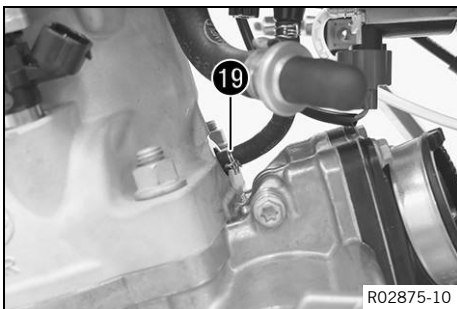

- Push back hose clamp 19.
- Pull off pressure sensor hose.

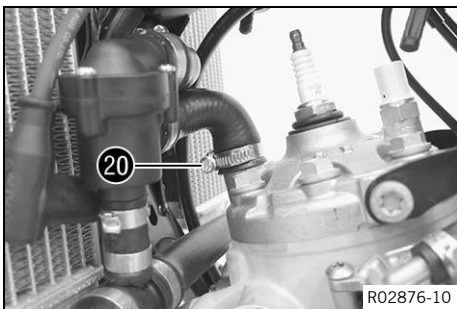

- Loosen hose clip 20.
- Pull off the radiator hose.

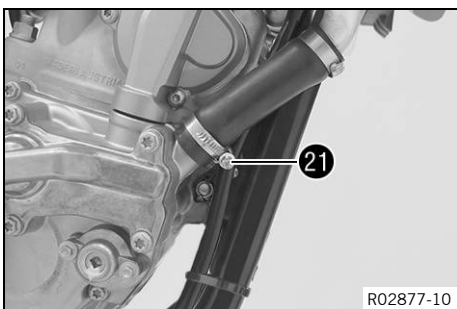

- Loosen hose clip 21.
- Pull off the radiator hose.

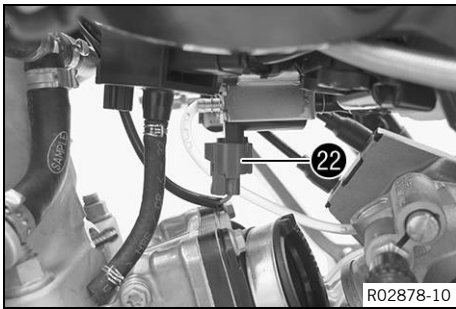

- Disconnect oil pump connector 22.

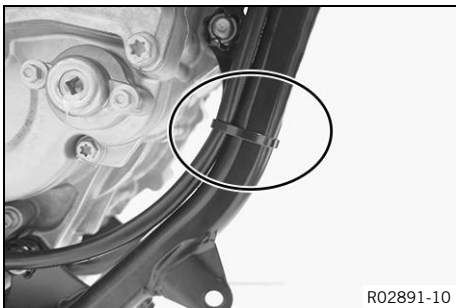

- Remove the cable tie.

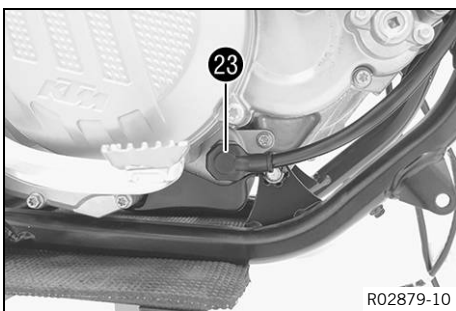

- Push back protection cap 23 and remove the nut.
- Hang the positive cable to the side.

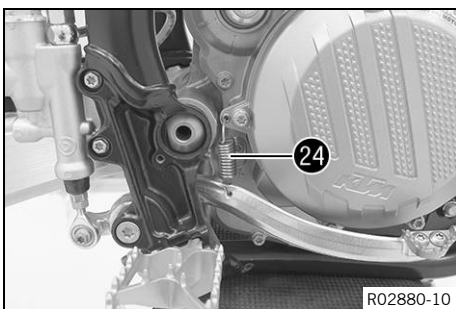

- Remove spring 24.

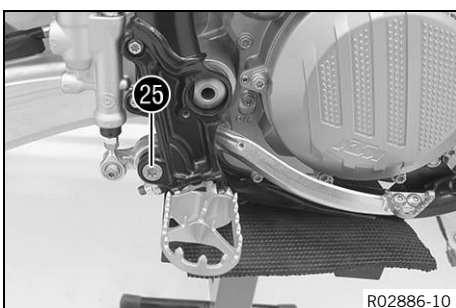

- Remove fitting 25.
- Slip the foot brake lever out toward the rear.

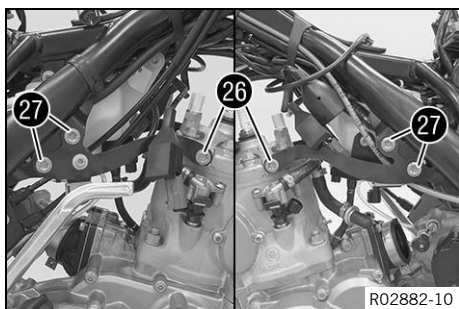

- Remove screws 26 and 27.
- Take off the engine braces.

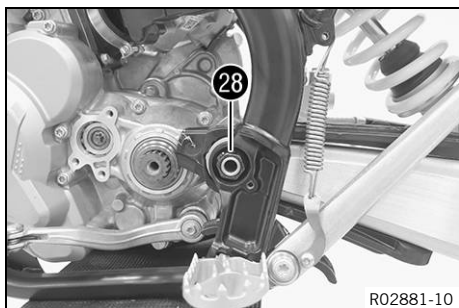

- Remove nut 28.
- Remove the swingarm pivot.
- Carefully pull the swingarm back, and secure the swingarm.

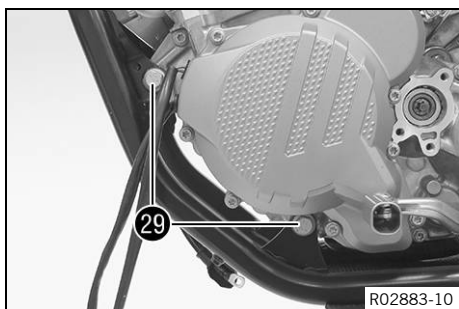

- Remove screws 29.



- Lift out the engine sideways to the right.

i Info

Pay attention to the oil pump.
The help of an assistant is useful in this step.
Make sure that the engine is sufficiently secured against falling over.
Protect the frame and attachments against damage.

18.3 Installing the engine



Main work

- Position the engine in the frame.

i Info

The help of an assistant is useful in this step.
Make sure that the engine is sufficiently secured against falling over.
Protect the frame and attachments against damage.
Pay attention to the oil pump.

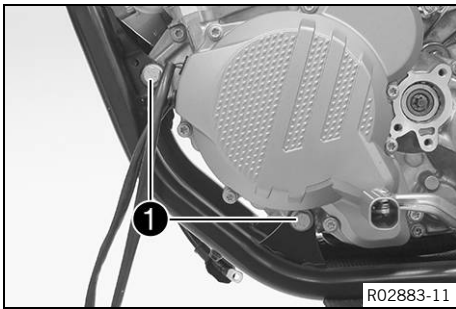

- Mount screws **1** but do not tighten yet.

Guideline

Engine bracket screw	M10	60 Nm (44.3 lbf ft)
----------------------	-----	---------------------

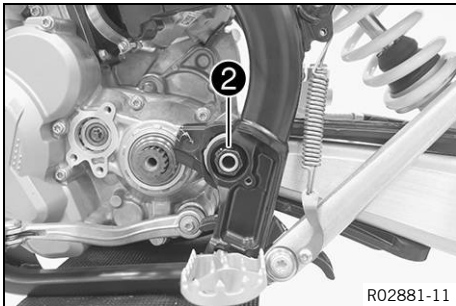

- Position the swingarm.
- Mount the swingarm pivot.
- Mount nut **2**, but do not tighten it yet.

Guideline

Nut, swingarm pivot	M16x1.5	100 Nm (73.8 lbf ft)
---------------------	---------	----------------------

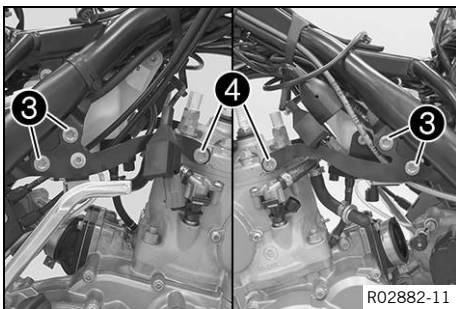

- Position the engine braces.
- Mount and tighten screws **3** and **4**.

Guideline

Screw, engine brace	M8	25 Nm (18.4 lbf ft) Loctite®2701™
---------------------	----	---

- Tighten screws **1** and nut **2**.

Guideline

Engine bracket screw	M10	60 Nm (44.3 lbf ft)
Nut, swingarm pivot	M16x1.5	100 Nm (73.8 lbf ft)

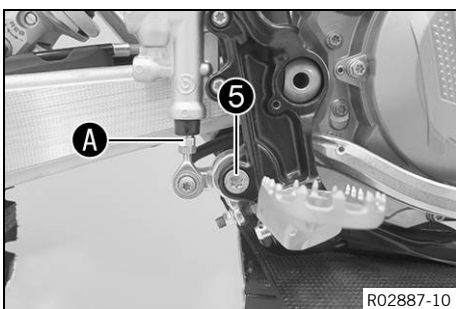

- Slip in the foot brake lever and position it.
- Mount and tighten fitting **5**.

Guideline

Nut, foot brake lever	M8	15 Nm (11.1 lbf ft)
-----------------------	----	---------------------

- ✓ Push rod **A** engages in the foot brake cylinder.
- ✓ The dust boot is correctly positioned.

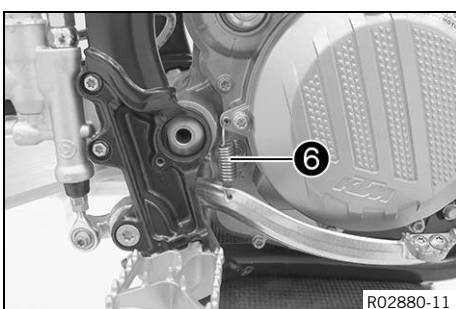

- Mount spring **6**.

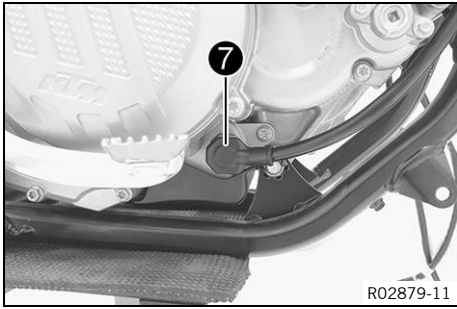

- Position the positive cable on the starter motor.
- Mount and tighten the nut.

Guideline

Remaining nuts, chassis	M6	10 Nm (7.4 lbf ft)
-------------------------	----	--------------------

- Position protection cap **7**.

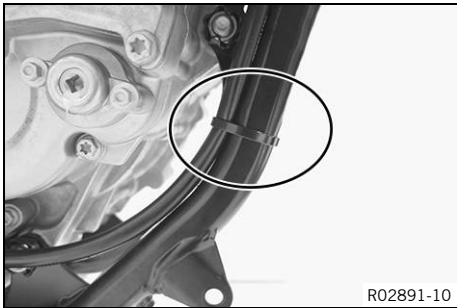

- Mount the cable tie.

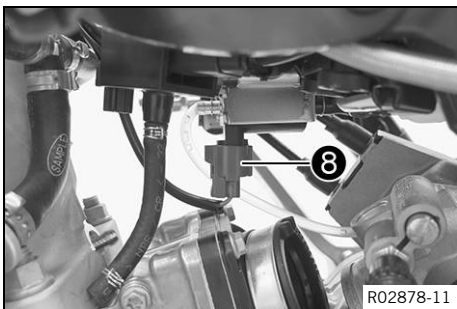

- Plug in oil pump connector **8**.

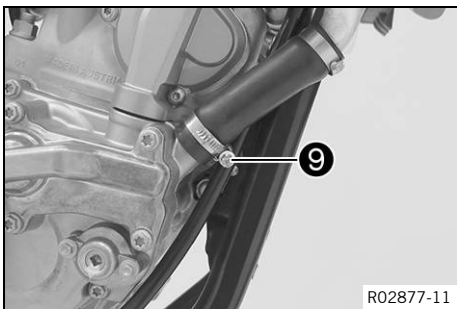

- Mount the radiator hose.
- Position and tighten hose clip **9**.

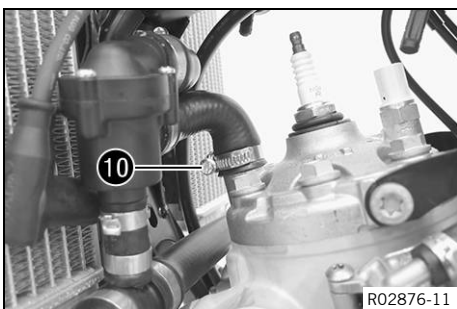

- Mount the radiator hose.
- Position and tighten hose clip **10**.

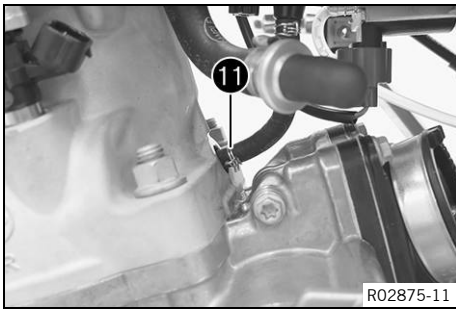

- Position pressure sensor hose.
- Position hose clamp 11.

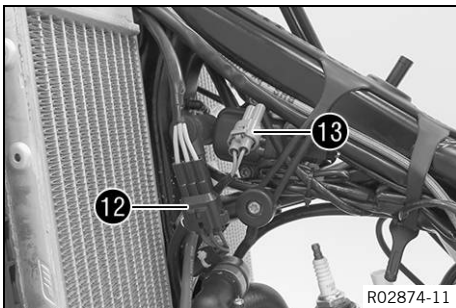

- Join plug-in connectors 12 and 13.

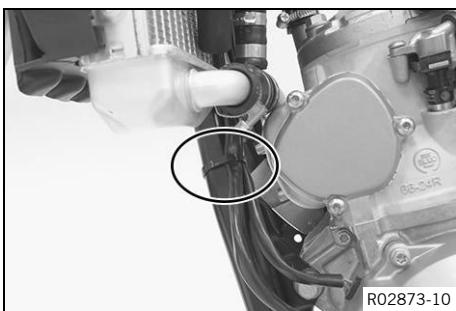

- Route the cable without tension and secure with cable tie(s).

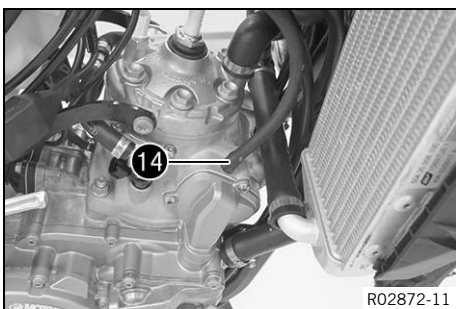

- Mount vent hose 14.



- Plug in the connectors.
- Position protection caps 15.

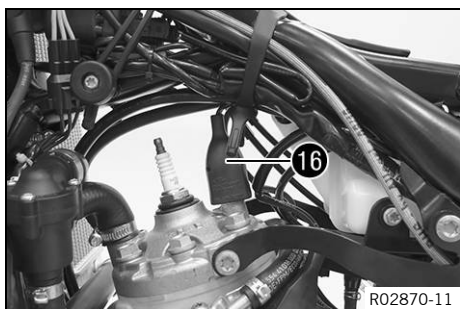

- Plug in the connector of the engine coolant temperature sensor.
- Position protection cap **16**.

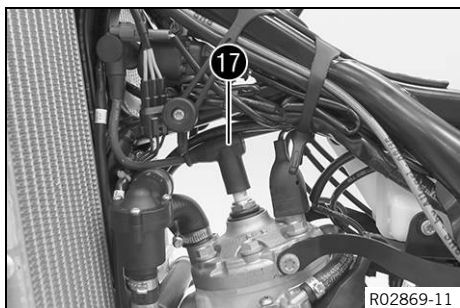

- Plug in spark plug connector **17**.

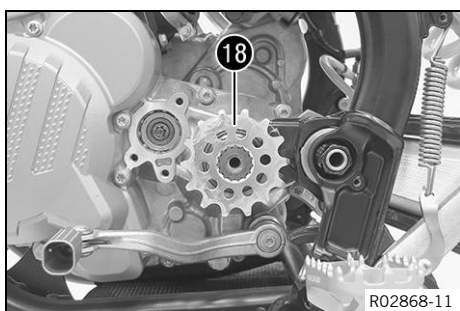

- Slide engine sprocket **18** onto the countershaft.

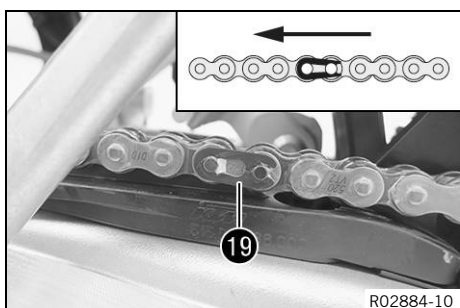

- Mount the chain.
- Connect the chain with connecting link **19**.

Guideline

The closed side of the chain joint lock must face in the direction of travel.

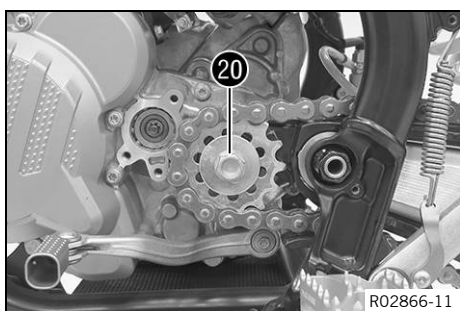

- Have an assistant operate the rear brake.
- Mount and tighten screw **20** with the washer.

Guideline

Screw, drive chain engine sprocket	M10	60 Nm (44.3 lbf ft) Loctite®2701™
------------------------------------	-----	---

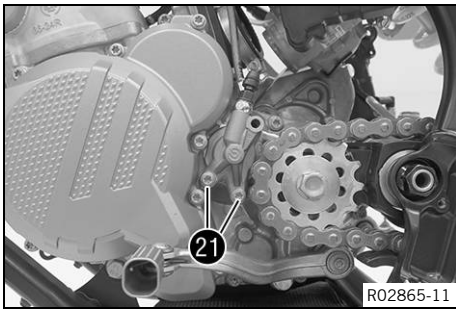

- Position the clutch slave cylinder with the gasket.
- Mount and tighten screws 21.

Guideline

Screw, clutch slave cylinder	M6	10 Nm (7.4 lbf ft)
------------------------------	----	--------------------

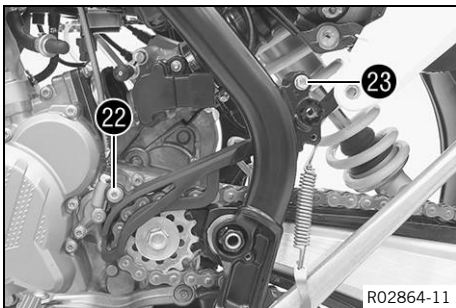

- Position the engine sprocket cover.
- Mount and tighten screw 22.

Guideline

Screw, clutch slave cylinder	M6	10 Nm (7.4 lbf ft)
------------------------------	----	--------------------

- Mount and tighten screw 23.

Guideline

Screw, engine sprocket cover	M8	20 Nm (14.8 lbf ft)
------------------------------	----	---------------------

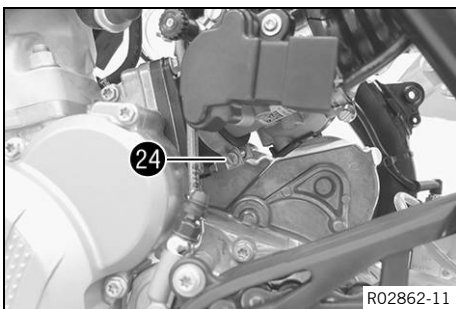

- Remove the locking piece and position the subframe.



Info

Watch out for the intake flange.

- Position hose clip 24 but do not tighten yet.

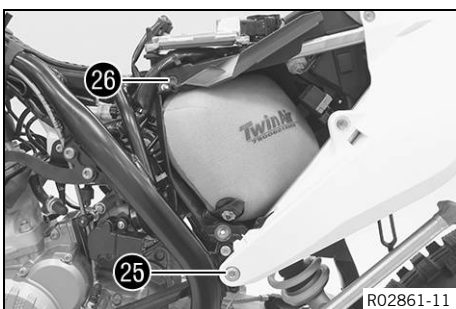

- Mount and tighten screw 25.

Guideline

Screw, sub-frame	M8	35 Nm (25.8 lbf ft) Loctite®2701™
------------------	----	---

- Remove screw 26.
- Mount and tighten screw 26.

Guideline

Screw, sub-frame	M8	35 Nm (25.8 lbf ft) Loctite®2701™
------------------	----	---

- Repeat these steps on the opposite side.
- Tighten hose clip 24.

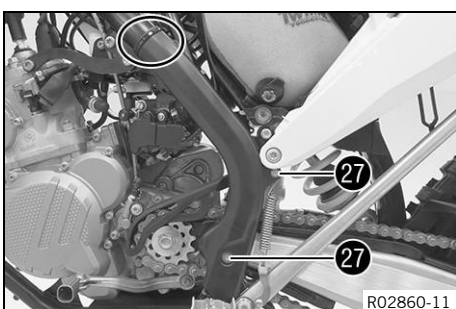

- Position the frame protector.
- Mount and tighten screws 27 with the washers.

Guideline

Screw, frame protector	M5	3 Nm (2.2 lbf ft)
------------------------	----	-------------------

- Mount the cable tie.

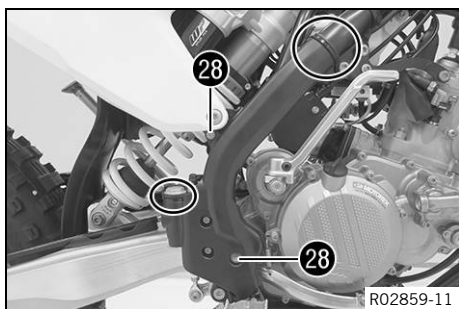

- Position the frame protector.
- Mount and tighten screws 28 with the washers.

Guideline

Screw, frame protector	M5	3 Nm (2.2 lbf ft)
------------------------	----	-------------------

- Mount the cable ties.
- Install the manifold. (📖 p. 112)

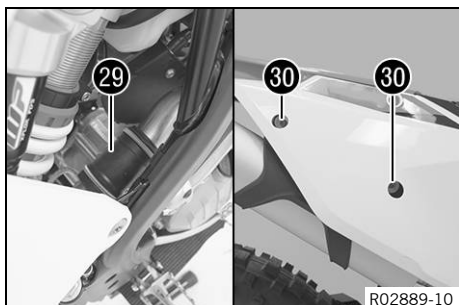

- Mount the main silencer with rubber sleeve 29.
- Mount and tighten screws 30 with the washers.

Guideline

Remaining screws, chassis	M6	10 Nm (7.4 lbf ft)
---------------------------	----	--------------------

- Connect the negative cable of the battery. (📖 p. 161)
- Install the fuel tank. (📖 p. 123)
- Install the air filter box cover. (📖 p. 116)
- Mount the seat. (📖 p. 121)

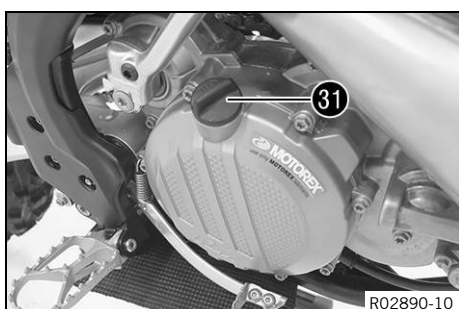

- Remove filler plug 31 with the O-ring, and fill up with gear oil.

Gear oil	0.80 l (0.85 qt.)	Engine oil (15W/50) (📖 p. 358)
----------	----------------------	--------------------------------------

- Mount and tighten filler plug 31 with the O-ring.

Finishing work

- Remove the motorcycle from the lift stand. (📖 p. 12)

(All Six Days models)

- Install the engine guard. (📖 p. 74)
- Refill with coolant. (📖 p. 288)
- Go for a short test ride.
- Check the engine for leak tightness.
- Check the gear oil level. (📖 p. 295)
- Check the coolant level. (📖 p. 287)

18.4 Engine disassembly

18.4.1 Clamping the engine into the engine work stand

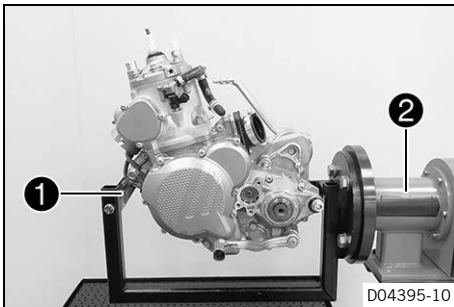

- Mount special tool **1** on engine work stand **2**.

Engine work stand (61229001000) (📖 p. 370)

Holder and fitting for work stand (55429002000)
(📖 p. 365)

- Mount the engine on special tool **1**.

18.4.2 Removing the shift lever

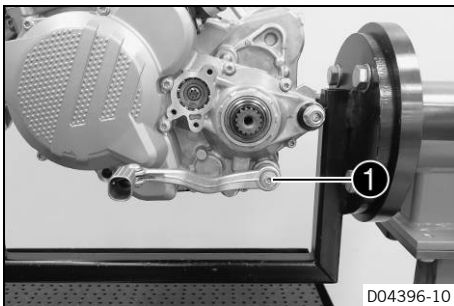

- Remove screw **1** with the washers. Take off the shift lever.

18.4.3 Removing the clutch push rod

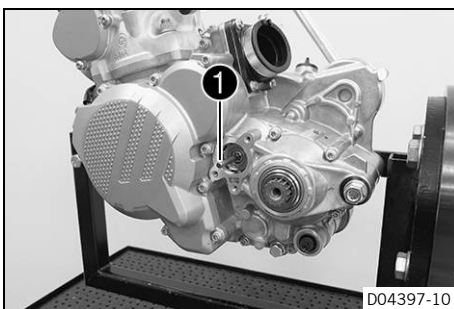

- Remove clutch push rod **1**.

18.4.4 Draining the gear oil

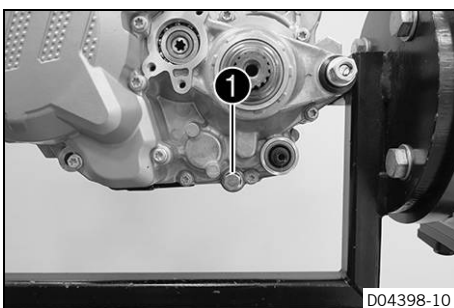

- Remove gear oil drain plug **1** with the magnet and seal ring.
- Let the gear oil drain fully.

18.4.5 Removing the spacer

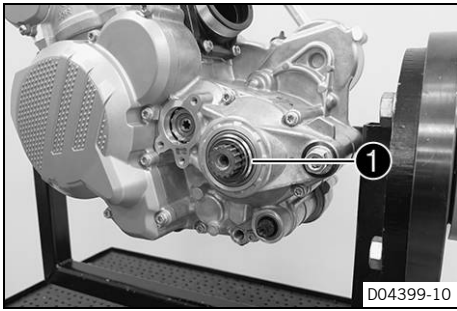

- Remove spacer ①.

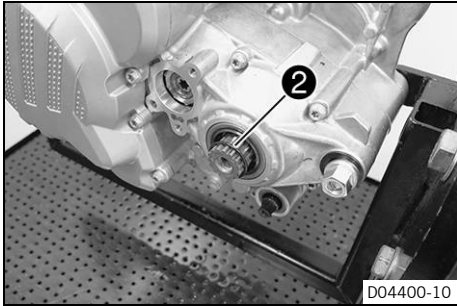

- Take off O-ring ②.

18.4.6 Removing the alternator cover

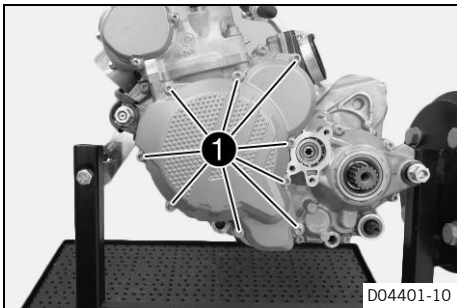

- Remove screws ①. Take off the alternator cover.

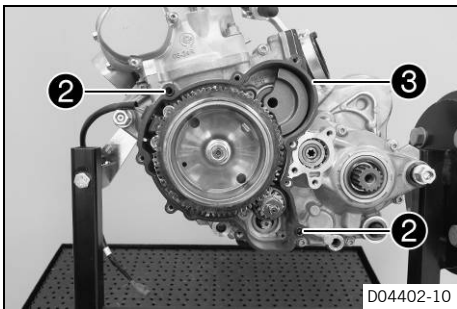

- Remove the dowels ② and alternator cover gasket ③.

18.4.7 Removing the kick starter

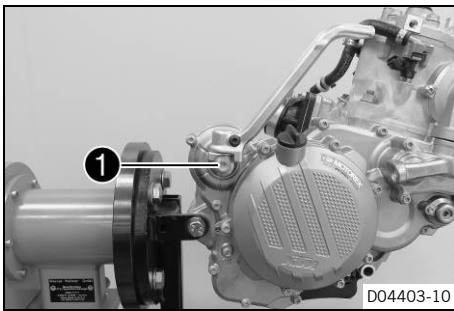

- Remove screw ① with the washer.
- Take off the kick starter.



18.4.8 Removing injection valves

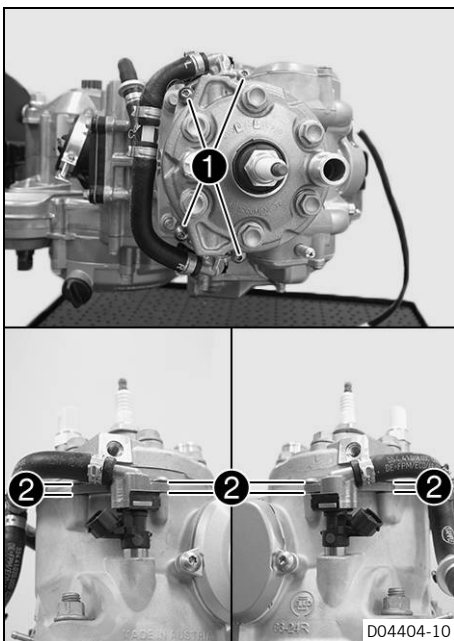

- Remove screws ① with insulating washers ②.
- Take off injection valves on both sides.



18.4.9 Removing the cylinder head

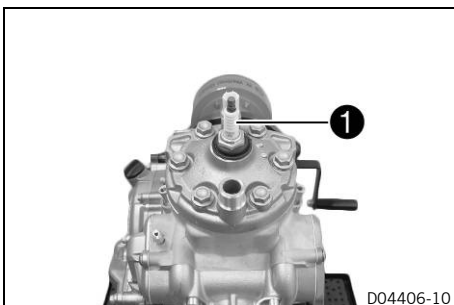

- Remove spark plug ①.

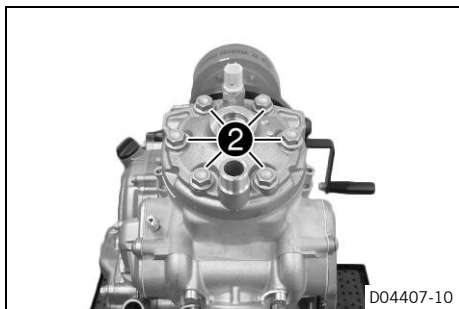

- Loosen screws **2** in a crisscross pattern and remove them.
- Remove the cylinder head.

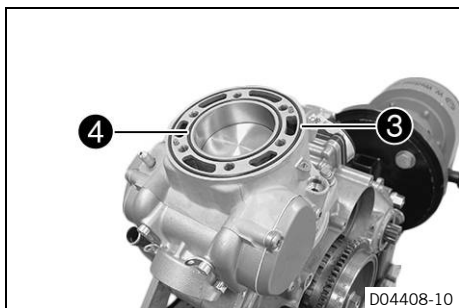

(All 250 models)

- Remove O-rings **3** and **4**.

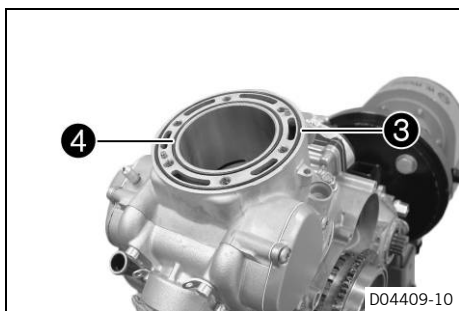

(All 300 models)

- Remove O-rings **3** and **4**.

18.4.10 Removing the cylinder

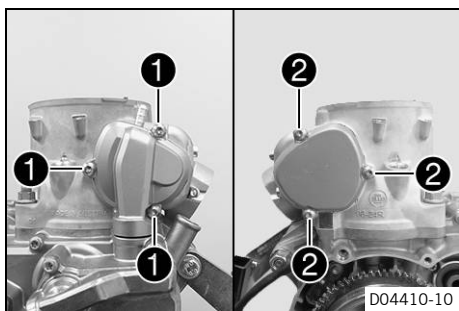

(All 250 models)

- Remove screws **1** and **2**.
- Take off both covers.

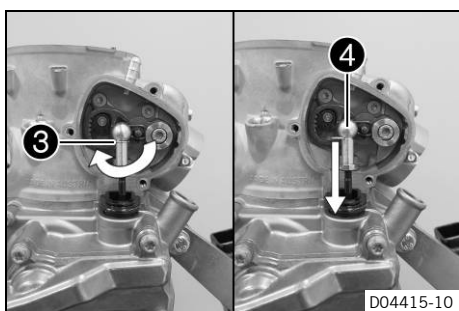

- Remove retainer **3** of ball socket **4**.
- Pull off the ball socket.
- Remove the gaskets on both sides.

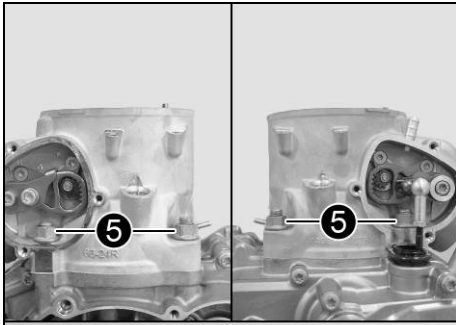

- Remove nuts ⑤.



Info

Raise the cylinder slightly to be able to remove the front nuts.

- Carefully slide the cylinder up and take it off.

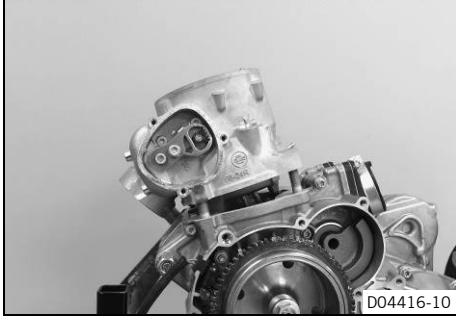

D04416-10

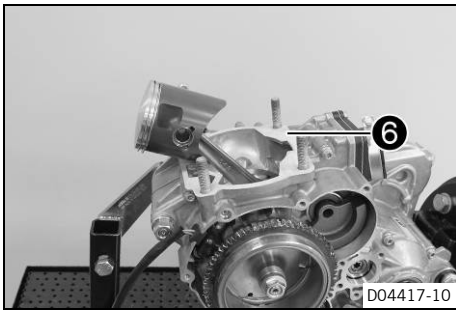

D04417-10

- Take off gasket ⑥.

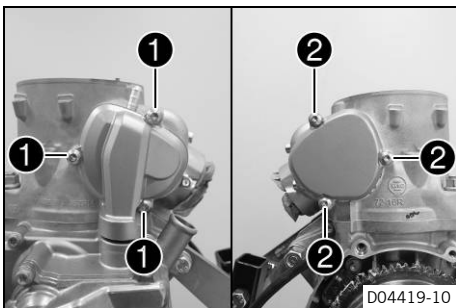

D04419-10

(All 300 models)

- Remove screws ① and ②.
- Take off both covers.

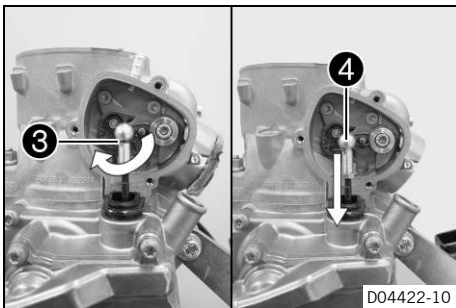

D04422-10

- Remove retainer ③ of ball socket ④.
- Pull off the ball socket.
- Remove the gaskets on both sides.

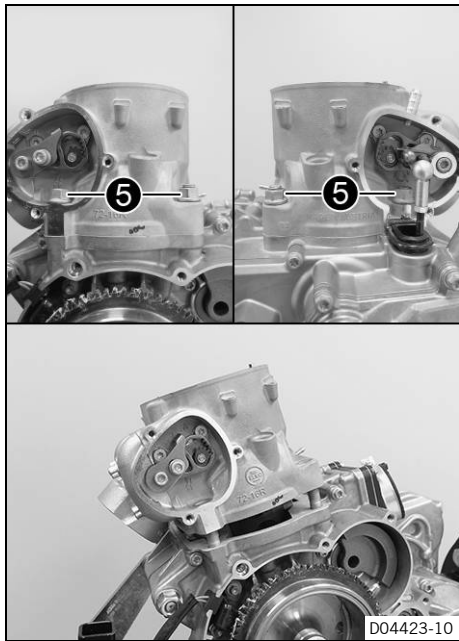

- Remove nuts **5**.

i Info
Raise the cylinder slightly to be able to remove the front nuts.

- Carefully slide the cylinder up and take it off.

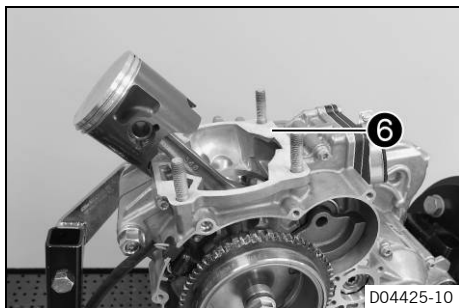

- Take off gasket **6**.

18.4.11 Removing the piston

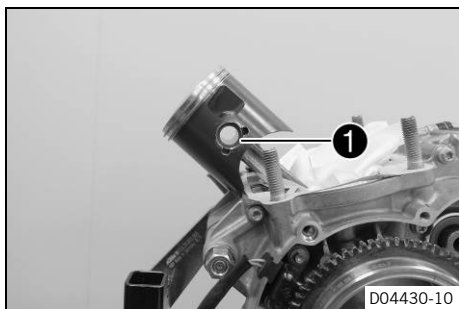

(All 250 models)

- Uncover the crankcase.
- Remove piston ring lock **1**.
- Remove the piston pin.
- Take off the piston.

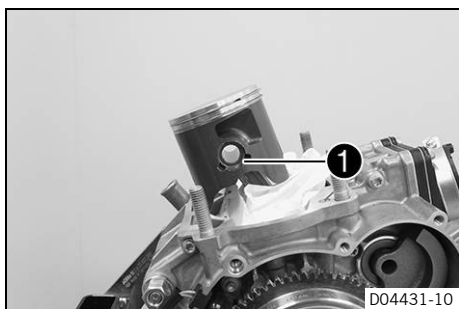

(All 300 models)

- Uncover the crankcase.
- Remove piston ring lock **1**.
- Remove the piston pin.
- Take off the piston.

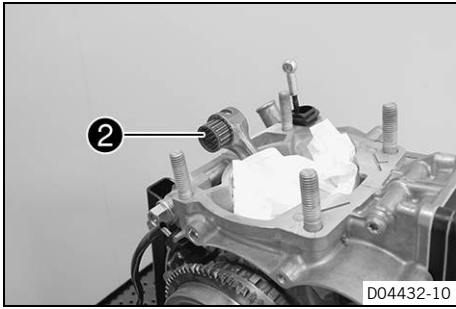

- Remove upper conrod bearing ②.



18.4.12 Removing the water pump cover

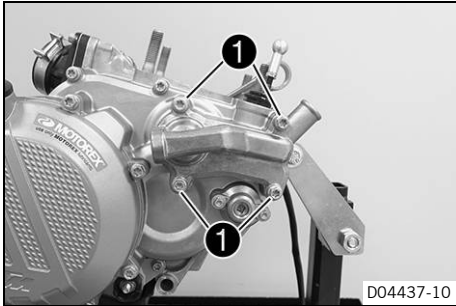

- Remove screws ①.
- Take off the water pump cover.
- Remove the form ring.

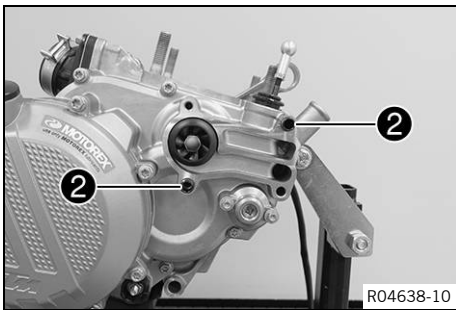

- Remove dowels ②.



18.4.13 Removing the clutch cover

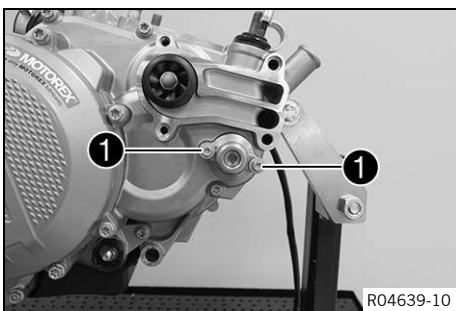

- Remove screws ①.
- Take off the cap.

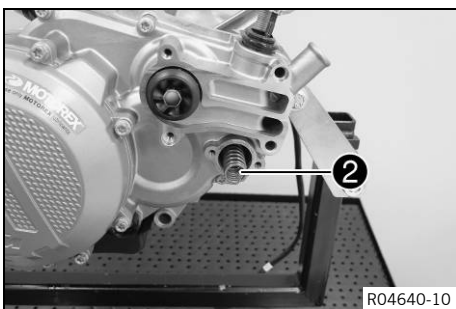

- Remove adjusting spring ② with the auxiliary spring and spring insert.

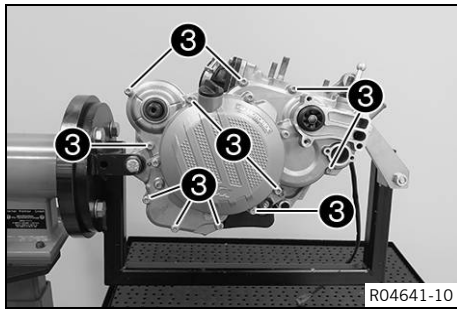

- Remove screws ③.

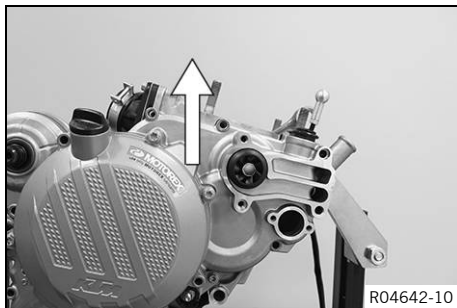

- Take off the clutch cover at the top and slip out the linkage.



Info

Ensure that the kick starter shaft remains in the engine case.

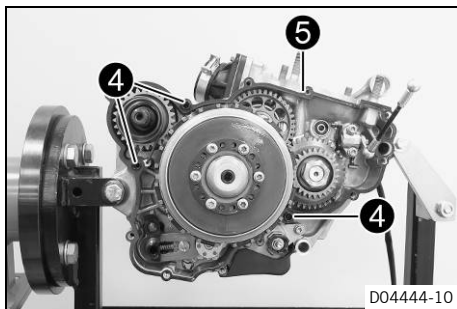

- Remove dowels ④ and clutch cover gasket ⑤.

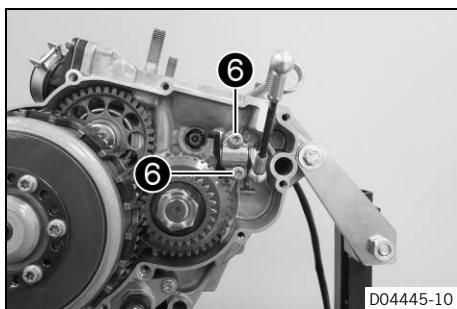

- Remove screws ⑥.
- Take off the bearing support with the linkage and angle lever.

18.4.14 Removing the clutch discs

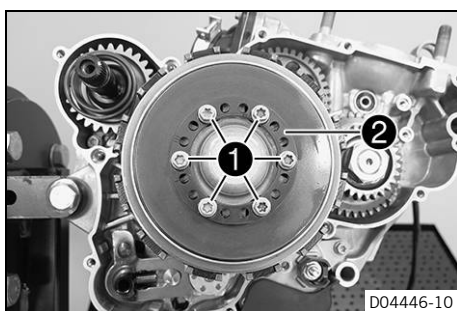

- Remove screws ①.
- Take off spring retainer ②.

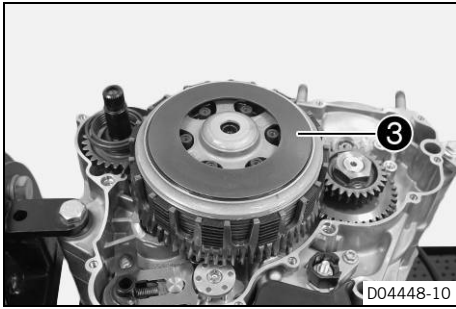

- Take off spring washer **3**.

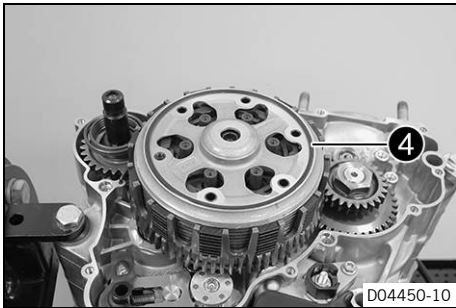

- Take off pretension ring **4**.

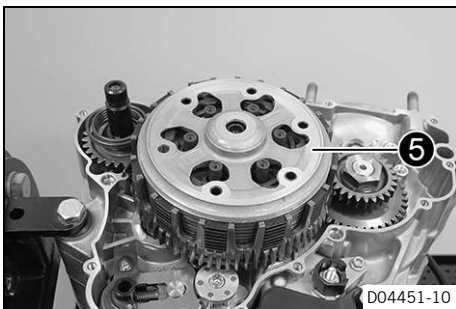

- Take off pressure cap **5**.

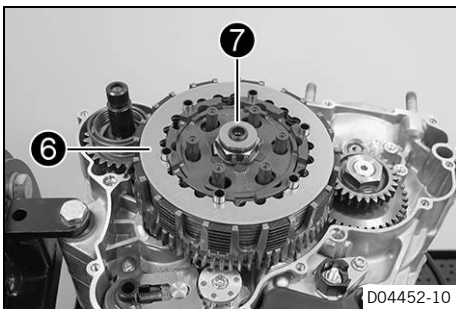

- Remove clutch disc pack **6** completely.
- Remove clutch throw-out **7**.

18.4.15 Removing the clutch basket

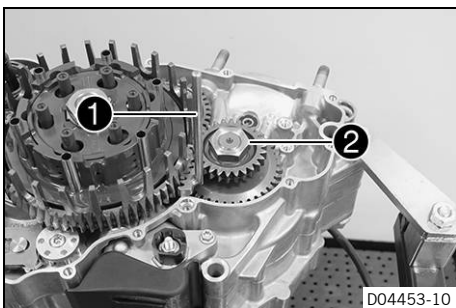

- Hold the primary gear using special tool **1**.

Gear segment (56012004000) (📖 p. 366)

- Remove nut **2** with the washer.



Info

Left-handed thread!

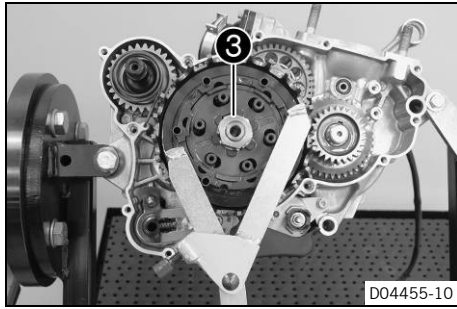

- Bend up the lock washer.
- Hold the inner clutch hub with the special tool. Loosen nut ③.

Holding wrench (51129003000) (p. 364)

- Remove the nut with the lock washer.

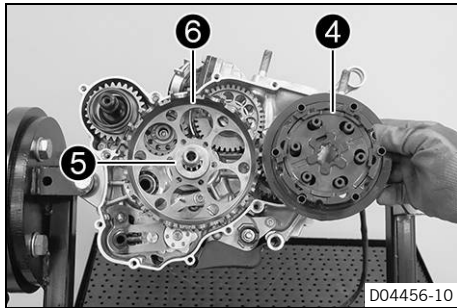

- Take off inner clutch hub ④ and washer ⑤.

i Info

The washer usually sticks to the inner clutch hub.

- Take off clutch basket ⑥.

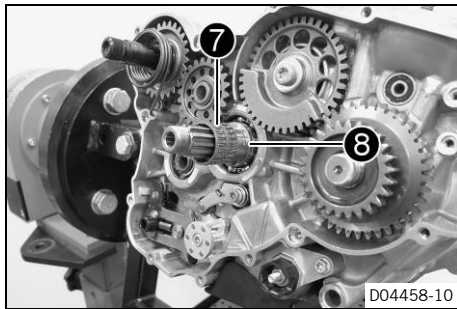

- Take off needle bearing ⑦ and collar bushing ⑧.

18.4.16 Removing the balancer shaft

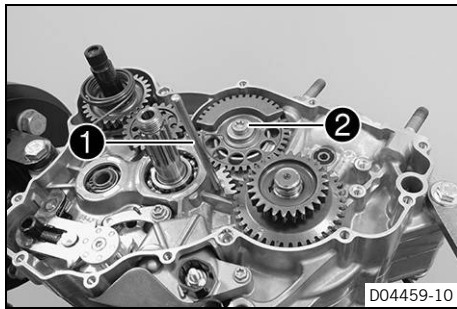

- Position the special tool.
- Hold the balancer shaft in place using the special tool ①.

Gear segment (56012004000) (p. 366)

- Remove screw ② with the washer.

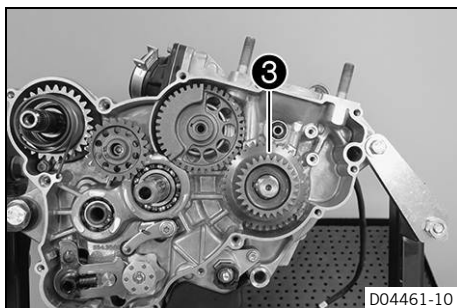

- Remove primary gear ③.

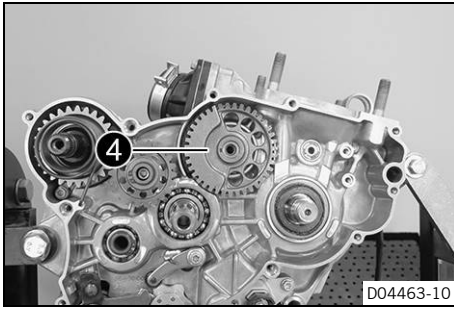

- Remove balancer shaft drive wheel ④.

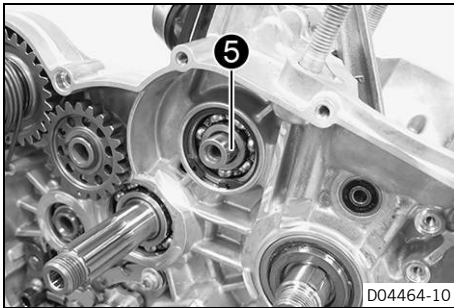

- Remove woodruff key ⑤.

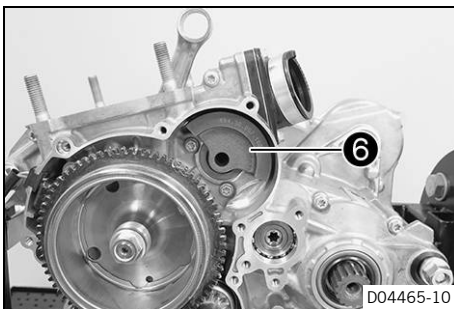

- Remove balancer shaft ⑥.

18.4.17 Removing the kick starter shaft

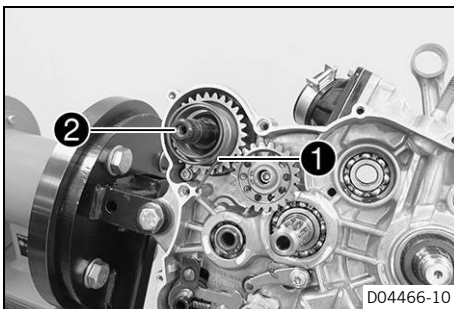

- Detach kick starter spring ①.
- Remove kick starter shaft ②.



Info

Turn the kick starter shaft slightly to the left.

18.4.18 Removing the intermediate kick starter gear

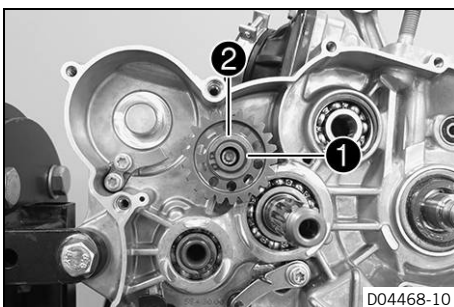

- Remove lock ring ① with washer ②.
- Take off intermediate kick starter gear.

18.4.19 Removing the shift shaft

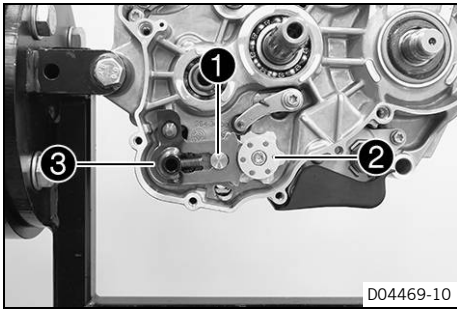

- Push sliding plate **1** away from shift drum locating unit **2**. Remove shift shaft **3** with washer.

D04469-10

18.4.20 Removing the shift drum locating unit

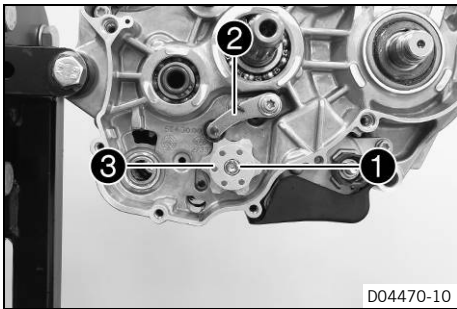

- Remove screw **1**.
- Push locking lever **2** away from shift drum locating unit **3** and take off the shift drum locating unit.
- Relieve tension from the locking lever.

D04470-10

18.4.21 Removing the locking lever

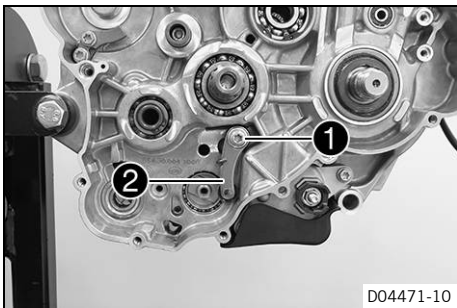

- Remove screw **1** with the washer.
- Take off locking lever **2** with the sleeve and spring.

D04471-10

18.4.22 Removing the rotor

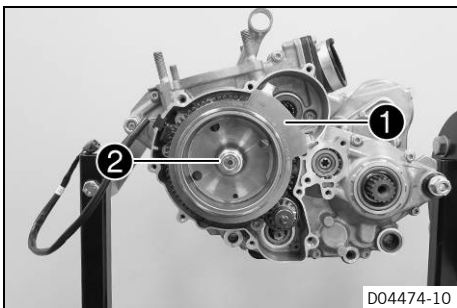

- Hold the rotor with special tool **1**.

Holding wrench (55429012000) (📖 p. 366)

- Remove nut **2** with the washer.

D04474-10

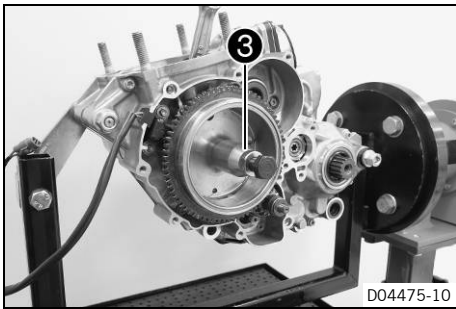

- Mount special tool **3**, apply counterpressure, and pull off the rotor by screwing in the screw.

Puller (58012009000) (📖 p. 367)

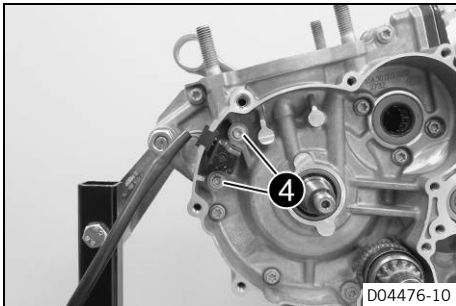

- Remove screws **4**.
- Take off the crankshaft position sensor.

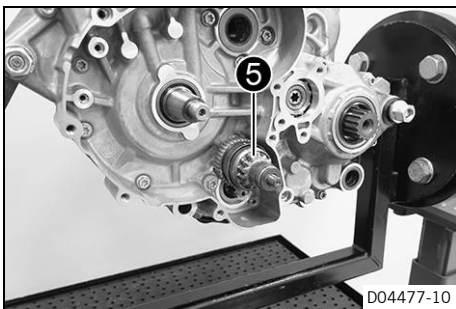

- Take off Bendix **5**.

18.4.23 Removing the starter motor

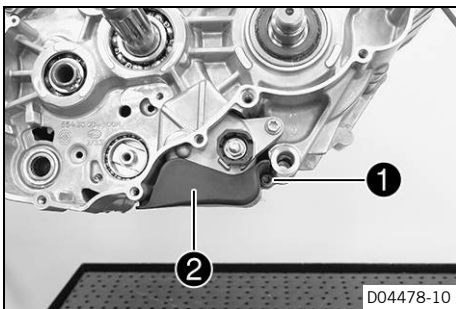

- Remove screw **1**.
- Take off cover **2**.

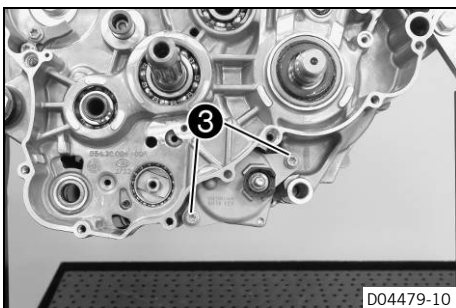

- Remove screws **3**.
- Pull the starter motor out of the engine case as far as possible.



Info

It is not possible to completely remove the starter motor.

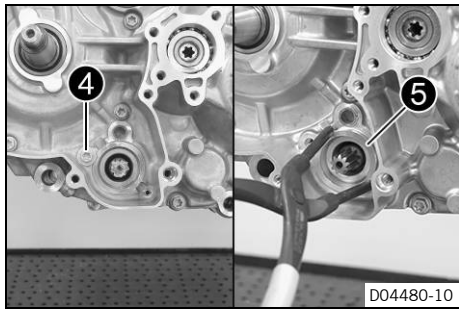

- Remove screw ④.
- Remove spacer ⑤ using the special tool.

Footrest spring plier (58429083000) (📖 p. 367)

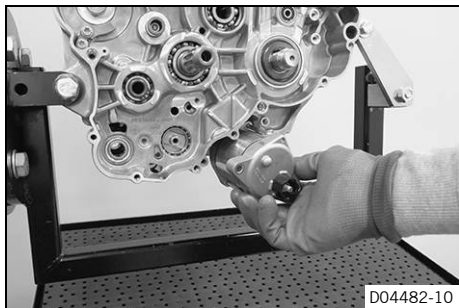

- Remove the starter motor.

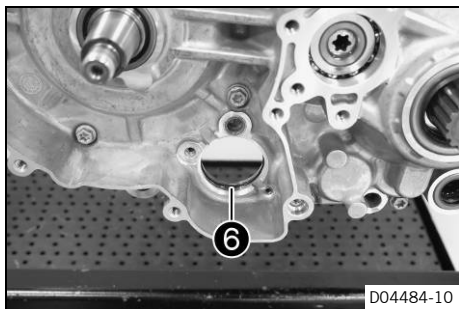

- Remove O-ring ⑥.

18.4.24 Removing the reed valve housing

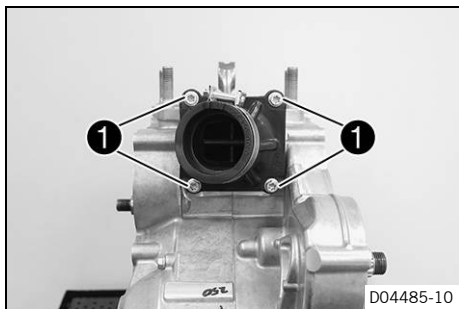

- Remove screws ①.
- Take off intake flange and gasket.

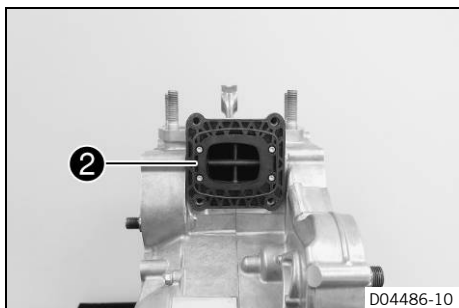

- Remove reed valve housing ②.
- Take off the gasket.

18.4.25 Removing the left engine case section

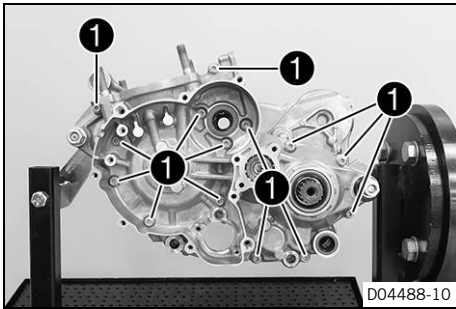

- Remove screws ①.
- Tilt the left section of the engine case upward and remove the fitting of the engine fixing arm.
- Loosen the left section of the engine case by striking it lightly with a plastic hammer and remove it.

i Info
Do not pry it apart with screwdrivers, since the sealing areas are easily damaged.

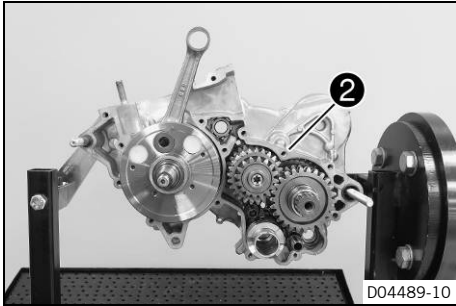

- Remove engine case gasket ②.

18.4.26 Removing the shift rails

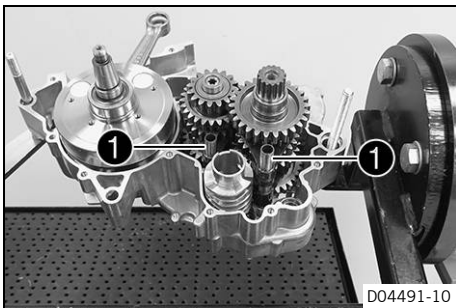

- Remove shift rails ①.

18.4.27 Removing the shift drum

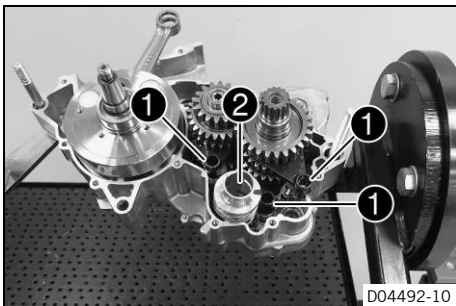

- Tilt shift forks ① to the side.
- Remove shift drum ②.

18.4.28 Removing the shift forks

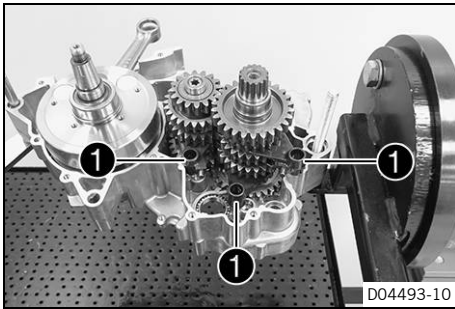

- Remove shift forks ①.



Info

Do not misplace the shift rollers.

18.4.29 Removing the transmission shafts

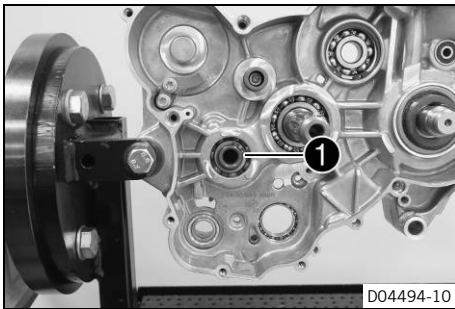

- Remove lock ring ①.

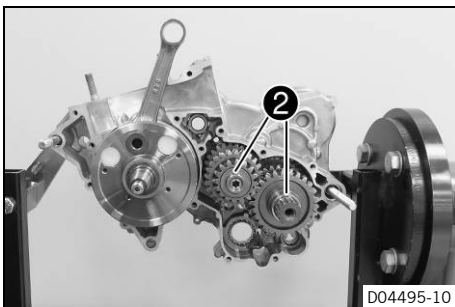

- Pull both transmission shafts ② out of the bearing seats together.



Info

The stop disks of the transmission shafts usually stick to the bearings.

18.4.30 Removing the crankshaft

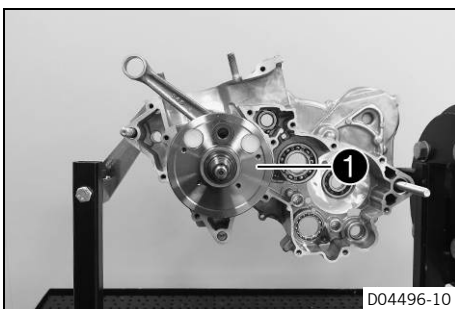

- Remove crankshaft ①.

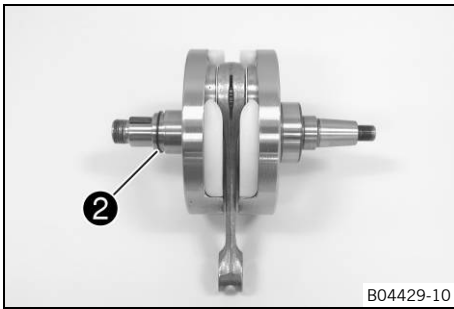

- Remove O-ring ②.

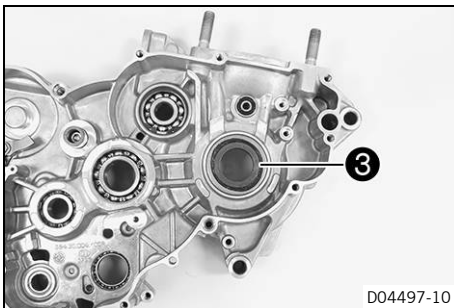

- Remove distance sleeve ③.

18.5 Working on individual parts

18.5.1 Working on the right section of the engine case

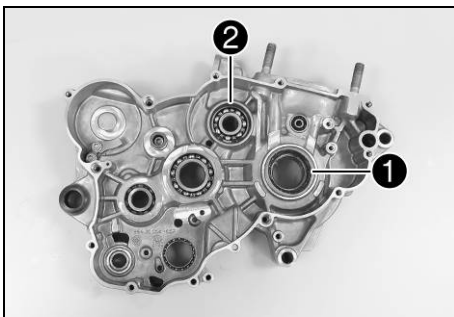

- Remove all dowels.
- Remove shaft seal ring ① of the crankshaft.
- Remove lock ring ②.
- Remove screws ③. Remove the bearing retainers.
- Clean the engine case section thoroughly.
- Warm the engine case section in an oven.

Guideline

180 °C (356 °F)

- Knock the engine case section against a level wooden board. This will cause the bearings to drop out of the bearing seats.

i Info

Any bearings that remain in the engine case section must be removed using a suitable tool.

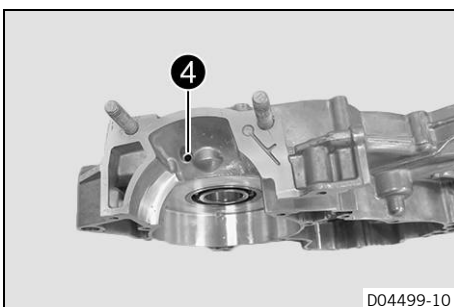
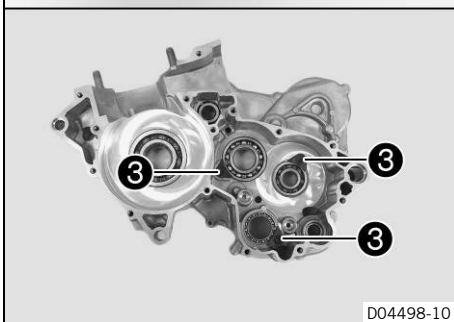

- Blow out lubrication bore ④ with compressed air and check that it is clear.
- Insert the new cold bearings in the bearing seats of the heated section of the engine case; if necessary, use a suitable press drift to push them all the way in and make them flush.

i Info
When pressing the bearings in, ensure that the engine case section is level to prevent damage.
Only press the bearings in via the outer ring; otherwise, the bearings will be damaged when they are pressed in.

- After the engine case section has cooled, check that the bearings are firmly seated.

i Info
If the bearings are not firmly seated after cooling, it is likely that they will rotate in the engine case when warm. In this case, the engine case must be renewed.

- Press in shaft seal ring **1** for the crankshaft so it is flush, with the open side facing inward.
- Mount lock ring **2**.
- Mount and tighten screws **3** with the bearing retainers.

Guideline

Screw, bearing retainer	M5	7 Nm (5.2 lbf ft) Loctite®243™
-------------------------	----	--

- Mount the dowels.

18.5.2 Working on the left section of the engine case

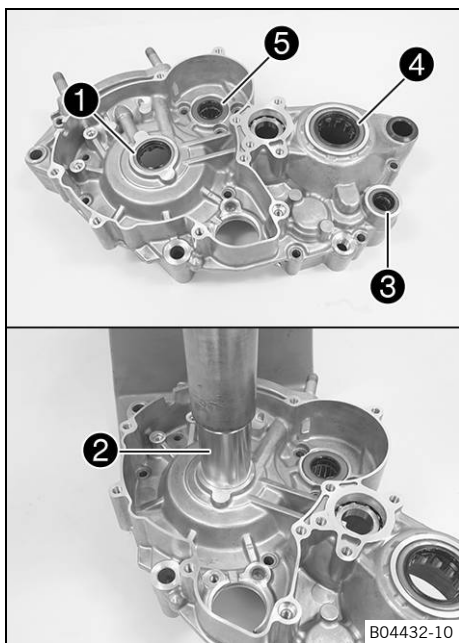

- Remove all dowels.
- Press shaft seal ring **1** of the crankshaft from the outside to the inside using special tool **2**.

Pressing tool (75029044010) (🗨 p. 370)

- Remove shaft seal ring **3** from the shift shaft and **4** from the countershaft.
- Remove shaft seal ring **5** from the balancer shaft.

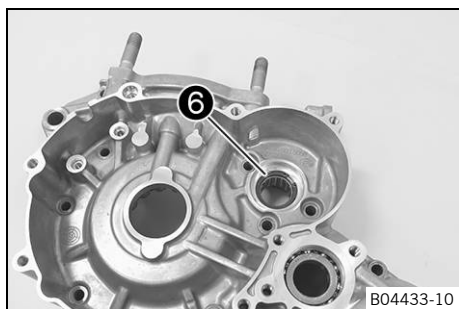

- Remove lock ring **6**.
- Clean the engine case section thoroughly.
- Warm the engine case section in an oven.

Guideline

180 °C (356 °F)

- Knock the engine case section against a level wooden board. This will cause the bearings to drop out of the bearing seats.

i Info

Any bearings that remain in the engine case section must be removed using a suitable tool.

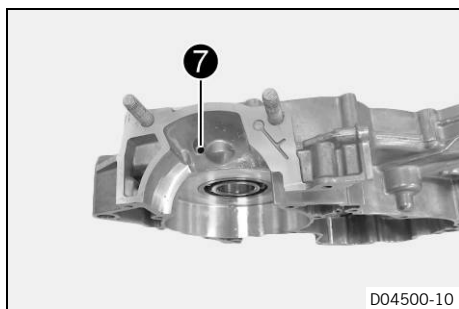

- Blow out lubrication bore **7** with compressed air and check that it is clear.

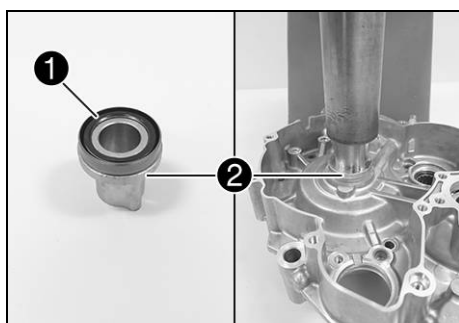

- Insert the new cold bearings in the bearing seats of the heated section of the engine case; if necessary, use a suitable press drift to push them all the way in and make them flush.

i Info

When pressing in, ensure that the section of the engine case lies flat in order prevent damage. Only press the bearings in via the outer ring; otherwise, the bearings will be damaged when they are pressed in.

- After the engine case section has cooled, check that the bearings are firmly seated.

i Info

If the bearings are not firmly seated after cooling, it is likely that they will rotate in the engine case when warm. In this case, the engine case must be renewed.

- Position shaft seal ring **1** for the crankshaft on special tool **2**.

Pressing tool (50429005000) (📖 p. 364)

- Press the shaft seal ring of the crankshaft from the outside to the inside with the open side facing inward.
- Mount lock ring **6**.

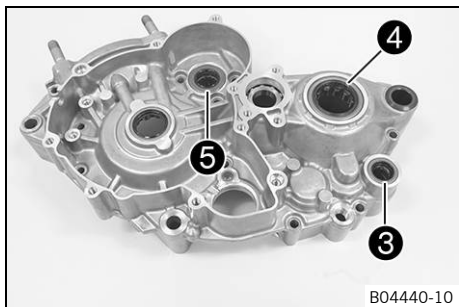

- Press in shaft seal ring ③ of the shift shaft so it is flush, with the open side facing inward.
- Press in shaft seal ring ④ of the countershaft so it is flush with the open side facing in.
- Press in shaft seal ring ⑤ for the balancer shaft so it is flush, with the open side facing inward.

18.5.3 Removing the crankshaft bearing inner race

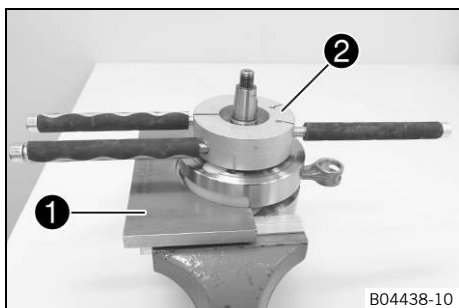

- Fixate the crankshaft in the vice with special tool ①.

Separator plate (54829009000) (📖 p. 365)

i Info
Use soft jaws.

- Warm up special tool ②.

Guideline

180 °C (356 °F)

Puller (58429037043) (📖 p. 367)

- Push the warmed up special tool ② onto the crankshaft bearing inner race, press firmly together, and pull jointly from the crankshaft.

18.5.4 Installing the crankshaft bearing inner race

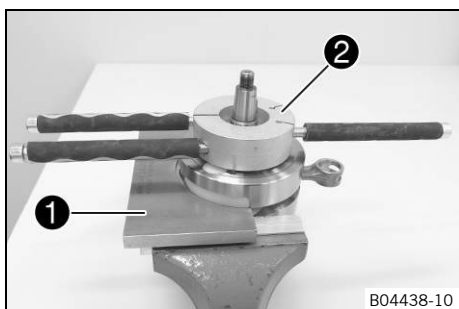

- Fixate the crankshaft in the vice with special tool ①.

Separator plate (54829009000) (📖 p. 365)

i Info
Use soft jaws.

- Heat the crankshaft bearing inner race in special tool ② and mount together.

Guideline

120 °C (248 °F)

Puller (58429037043) (📖 p. 367)

- Ensure that the new crankshaft bearing inner race is flush.

18.5.5 Changing the connecting rod, conrod bearing, and crank pin

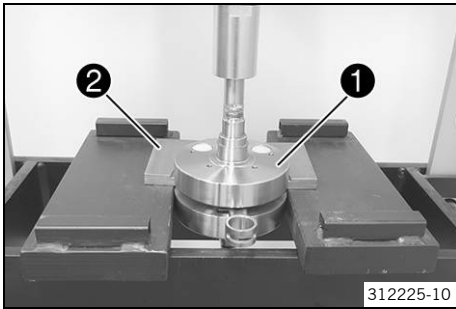

Main work

- Position crankshaft 1 in the press using special tool 2.

Separator plate (54829009000) (📖 p. 365)

- Press the crank pin out of the upper crankweb with a suitable tool.



Info

Hold the lower crankweb.

- Remove the connecting rod and bearing.
- Press the crank pin out of the lower crankweb.

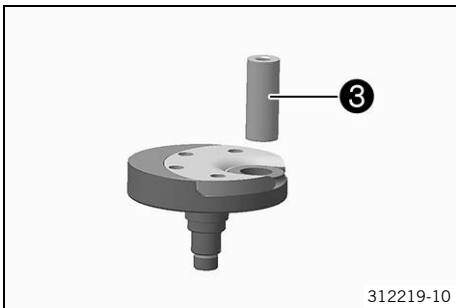
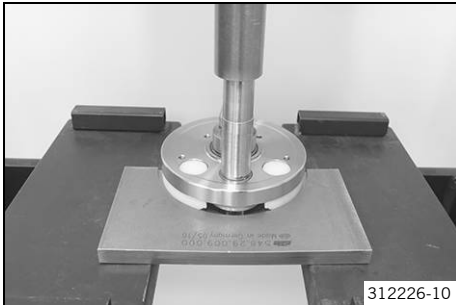

- Lubricate the new crank pin 3 and push in up to the stop.

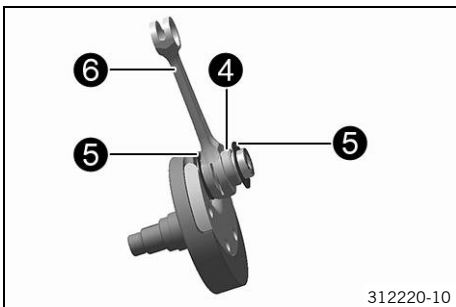

- Mount new bearing 4 with washers 5 and connecting rod 6.



Info

Thoroughly oil the bearing.

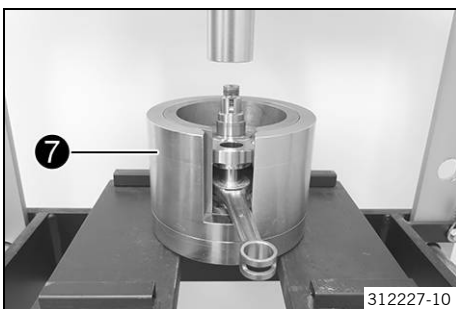

- Position special tool 7 on the press.

Crankshaft pressing tool (75029047000) (📖 p. 370)

Crankshaft pressing tool insert (54829108000) (📖 p. 365)

- Insert the crankweb with the connecting rod and bearing. Position the second crankweb.

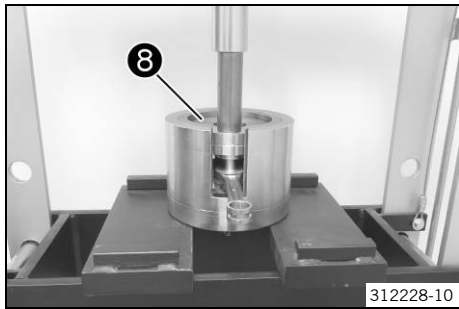

- Position special tool **8** with the heel pointing down.

Crankshaft pressing tool insert (54829108000) (📖 p. 365)

- Press in the upper crankweb as far as possible.



Info

The press mandrel must be positioned over the crank pin.

- Take the crankshaft out of the special tool and check that the connecting rod can move freely.

- Measure axial play **A** between the connecting rod and the crankwebs using the special tool.

Feeler gauge (59029041100) (📖 p. 369)

Connecting rod - axial play of lower conrod bearing	0.60 ... 0.70 mm (0.0236 ... 0.0276 in)
---	---

- » If the measured value is less than the specification:
 - Correct it so the dimension is equal to the specified value.

Finishing work

- Check the crankshaft run-out at the bearing pin. (📖 p. 224)

18.5.6 Checking the crankshaft run-out at the bearing pin

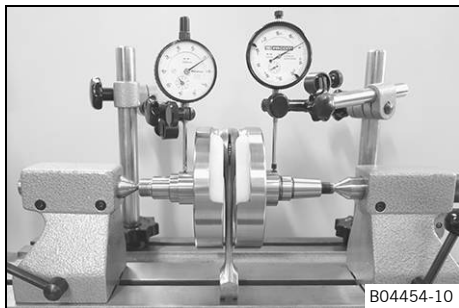

- Position the crankshaft on a roller block.
- Turn the crankshaft slowly.
- Check the crankshaft run-out on both bearing pins.

Crankshaft - run-out at bearing pin	$\leq 0.03 \text{ mm}$ ($\leq 0.0012 \text{ in}$)
-------------------------------------	---

- » If the crankshaft run-out at the bearing pin is larger than the specification:
 - Align the crankshaft.

18.5.7 Checking/measuring the cylinder

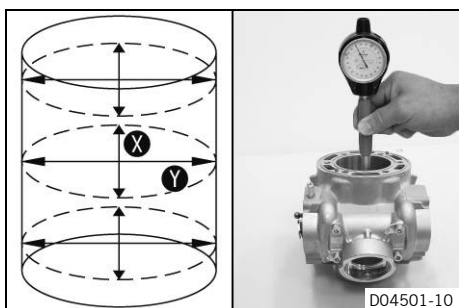

- Check the cylinder bearing surface for damage.
 - » If the cylinder bearing surface is damaged:
 - Change the cylinder and piston.
- Measure the cylinder diameter at several locations on the **X** and **Y** axes using a micrometer to identify oval wear.

Guideline

Cylinder - drill hole diameter (All 250 models)	
Size I	66.400 ... 66.412 mm (2.61417 ... 2.61464 in)
Size II	66.412 ... 66.425 mm (2.61464 ... 2.61515 in)
Cylinder - drill hole diameter (All 300 models)	
Size I	72.000 ... 72.012 mm (2.83464 ... 2.83511 in)
Size II	72.012 ... 72.025 mm (2.83511 ... 2.83562 in)

i Info
The cylinder size ① is labeled on the right side of the cylinder.

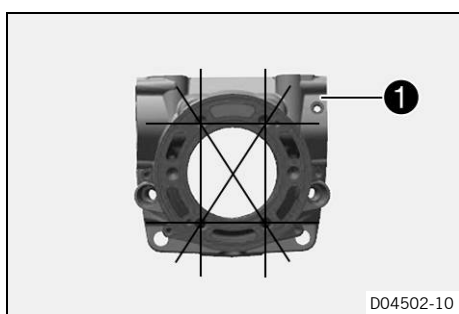

- Using a straightedge and the special tool, check the sealing surface of the cylinder head for distortion.

Feeler gauge (59029041100) (📖 p. 369)

Cylinder/cylinder head - distortion of sealing surface	≤ 0.10 mm (≤ 0.0039 in)
--	-------------------------

- » If the measured value does not meet specifications:
 - Change the cylinder.



18.5.8 Cleaning the pressure sensor cylinder connection

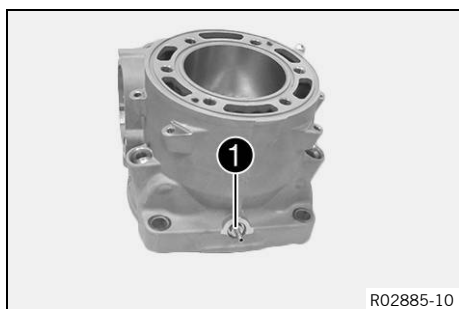

- Clean cylinder connection ① thoroughly and blow out with compressed air.



18.5.9 Removing the exhaust control

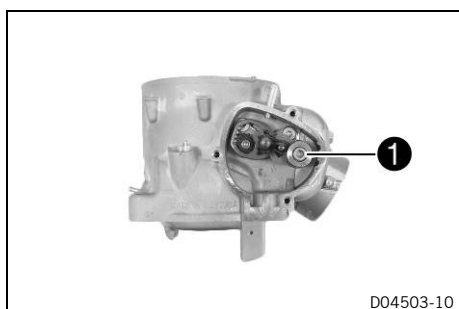

- Remove screw ① with the bushing and spring.

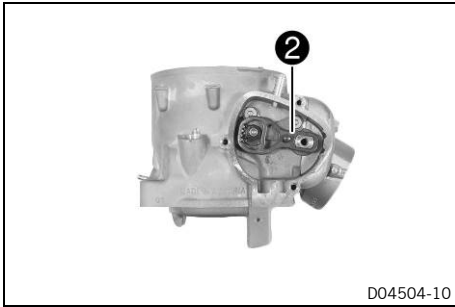

- Take off gear segment ②.

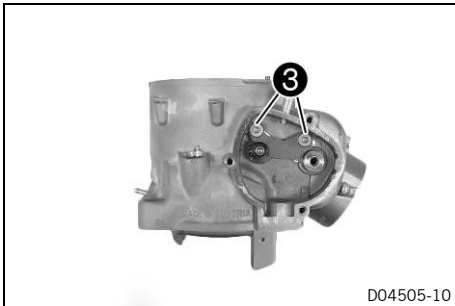

- Remove screws ③.
- Take off the retaining bracket.

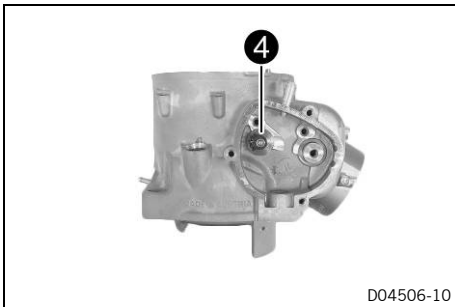

- Remove control shaft ④.

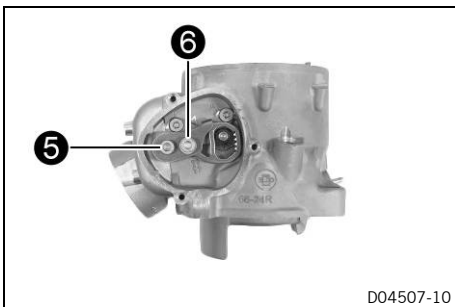

- Remove screw ⑤.
- Remove screw ⑥ with washer.
- Take off the stop plate.

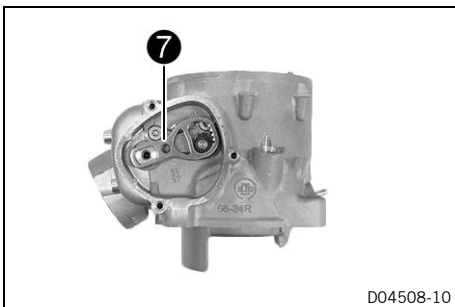

- Take off gear segment ⑦.

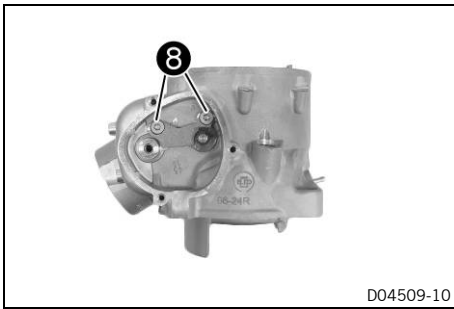

- Remove screws 8.
- Take off the retaining bracket.

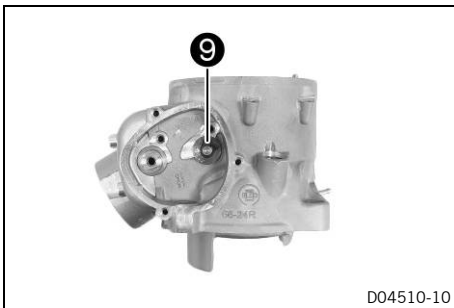

- Remove control shaft 9.

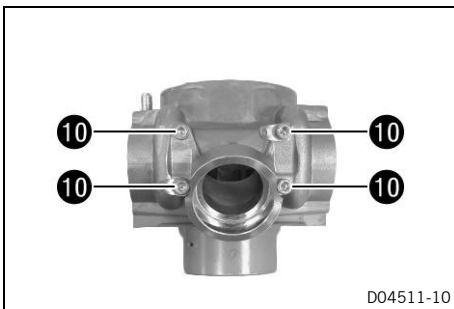

- Remove screws 10.
- Take off the exhaust flange.

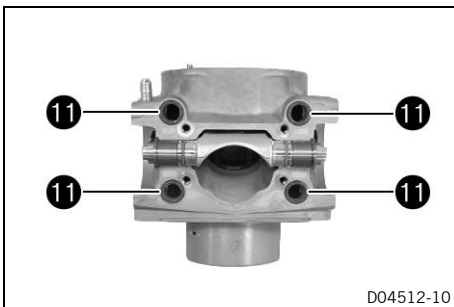

- Remove O-rings 11.
- Take off the control flap.

18.5.10 Checking the exhaust control

Condition

The exhaust control and centrifugal timer are removed.

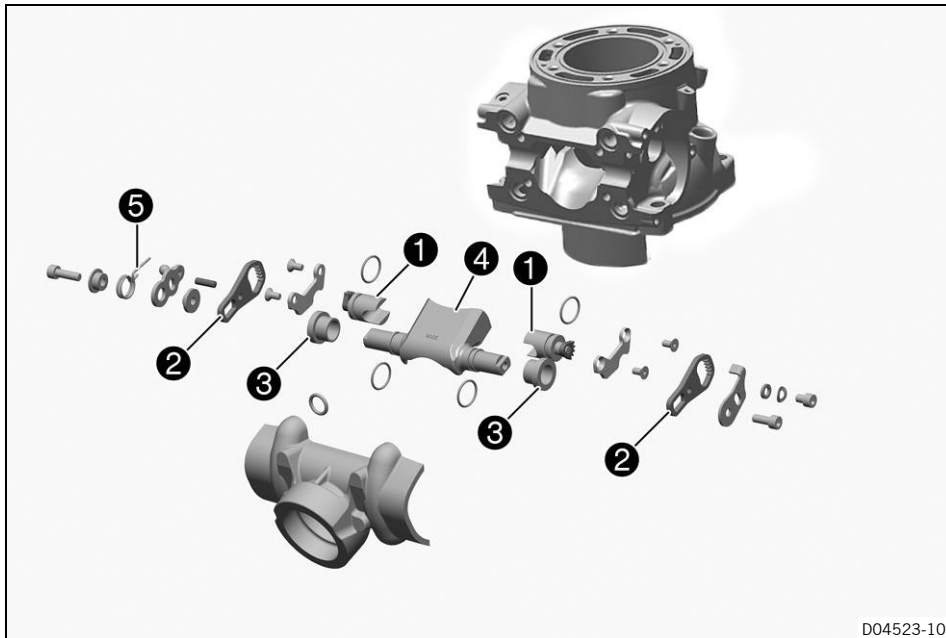

D04523-10

- Check control shafts **1** for damage and wear.
 - » If there is damage or wear:
 - Change the control shaft.
- Check gear segments **2** for damage and wear.
 - » If there is damage or wear:
 - Change the gear segments.
- Check bearing sleeves **3** for damage and wear.
 - » If there is damage or wear:
 - Change the bearing sleeves.
- Check control flap **4** for damage and wear.
 - » If there is damage or wear:
 - Change the control flap.
- Check spring **5** for damage and wear.
 - » If there is damage or wear:
 - Change the spring.

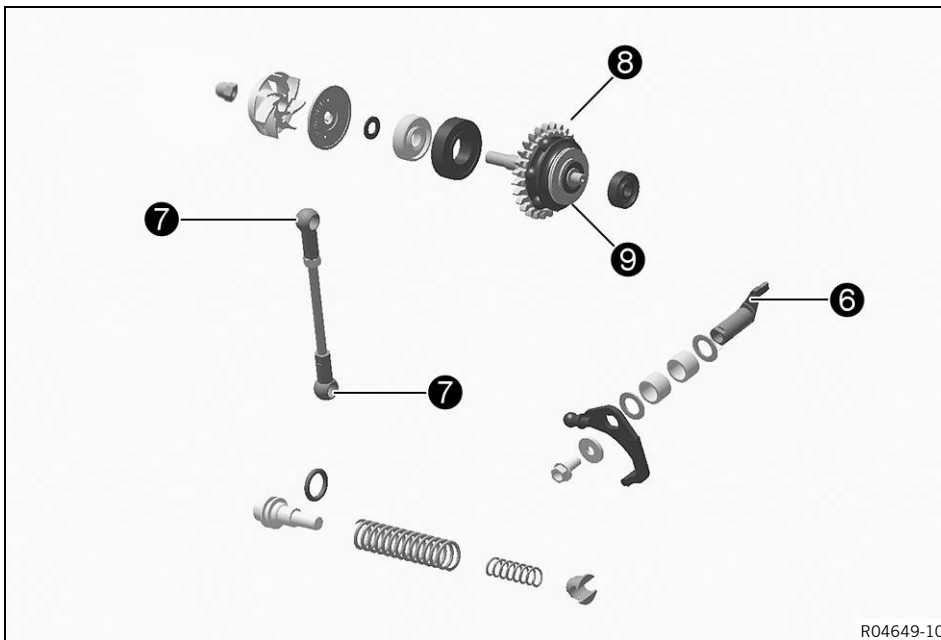

R04649-10

- Check pins **6** of the control lever for damage and wear.
 - » If there is damage or wear:
 - Change the control lever.
- Check ball head **7** on the linkage for damage and wear.
 - » If there is damage or wear:
 - Change the linkage.
- Check centrifugal timer **8** for damage and wear.
 - » If there is damage or wear:
 - Change the centrifugal timer.
- Check axial bearing **9** for damage and wear.
 - » If there is damage or wear:
 - Change the axial bearing.



18.5.11 Installing the exhaust control

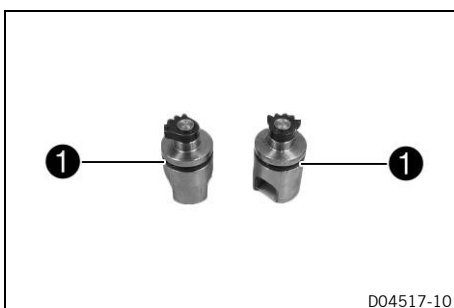

D04517-10

- Mount and grease O-rings **1**.

Long-life grease (📖 p. 360)

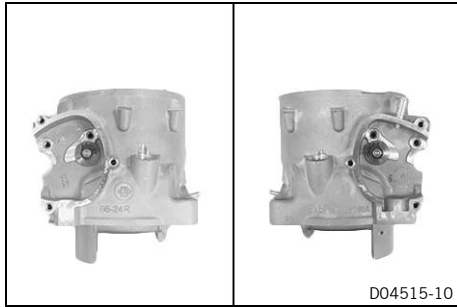

- Mount the control shafts.
- ✓ The control shaft with marking **Lis** installed on the left.

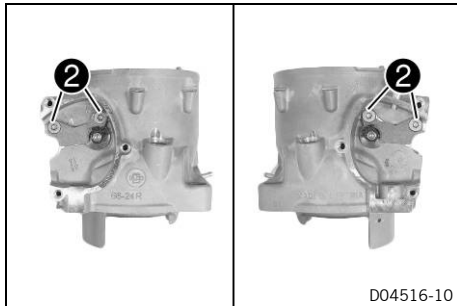

- Mount the retaining brackets.
- Mount and tighten screws **2**.

Guideline

Screw, retaining bracket of exhaust control	M5	7 Nm (5.2 lbf ft) Loctite®2701™
---	----	---

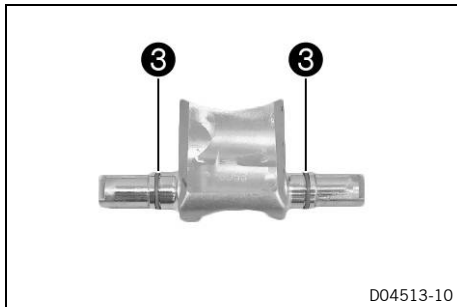

- Mount and grease O-rings **3**.

Long-life grease (📖 p. 360)

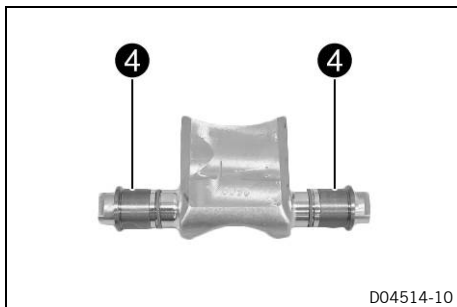

- Mount and grease bearing sleeves **4**.

Long-life grease (📖 p. 360)

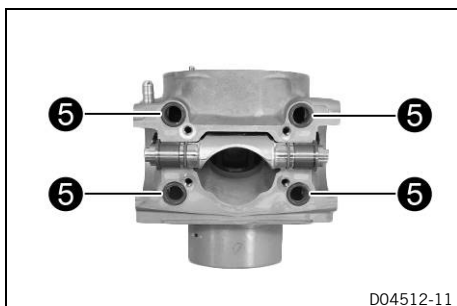

- Set the control flap to the open position.
- Mount O-rings **5**.

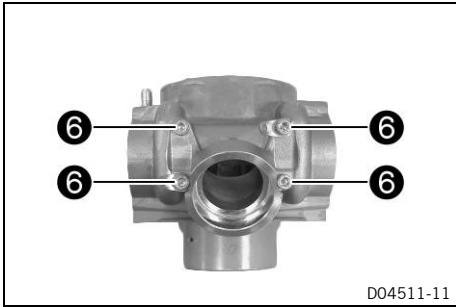

- Degrease the sealing surface and coat thinly with sealant.

Loctite® 5910

- Position the exhaust flange.
- Mount and tighten screws ⑥.

Guideline

Screw, exhaust flange	M6	8 Nm (5.9 lbf ft)
-----------------------	----	-------------------



Info

Do not forget the spring hangers.

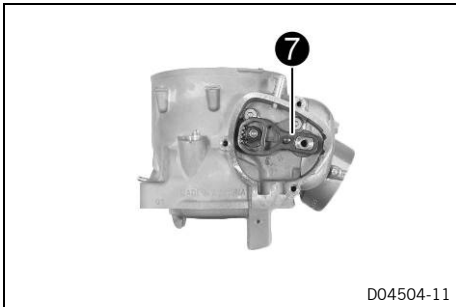

- Position gear segment ⑦.

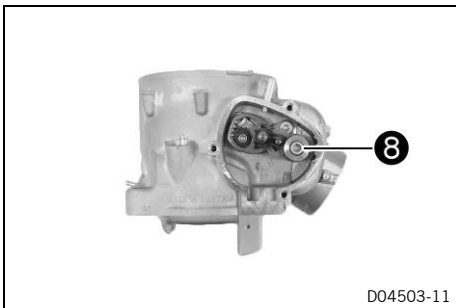

- Position the spring with the short leg toward the outside.
- Mount screw ⑧ with the bushing and spring but do not tighten yet.

Guideline

Screw, control flap, exhaust control	M6	10 Nm (7.4 lbf ft) Loctite®243™
--------------------------------------	----	---

- Attach the spring to the cylinder pin.
- Tighten the screw.

Guideline

Screw, control flap, exhaust control	M6	10 Nm (7.4 lbf ft) Loctite®243™
--------------------------------------	----	---

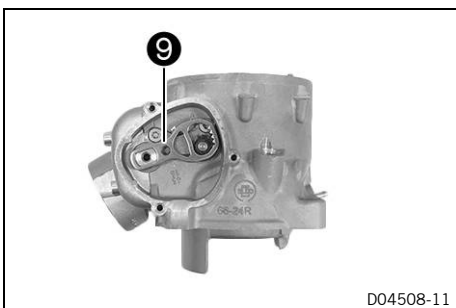

- Position gear segment ⑨.

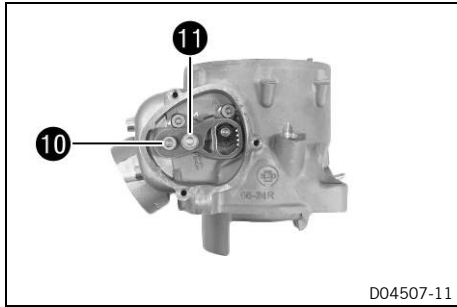

- Position the stop plate.
- Mount screw 10 but do not tighten yet.
- Mount screw 11 with the washer but do not tighten yet.



Info

The screws are tightened when the Z dimension is adjusted.

18.5.12 Cylinder - Nikasil® coating



Nikasil® is a surface protection layer for a coating procedure developed by Mahle. The name is derived from the two materials used in this procedure – a layer of nickel into which is embedded the particularly hard silicone carbide. The most important advantages of the **Nikasil®** coating are very good heat conductivity, resulting in much improved performance, low wear, and a lightweight cylinder.

18.5.13 Checking/measuring the piston



- Check the piston bearing surface for damage.
 - » If the piston bearing surface is damaged:
 - Replace the piston and, if necessary, the cylinder.
- Check that the piston rings move easily in the piston ring grooves.
 - » If the piston ring is stiff:
 - Clean the piston ring groove.



Tip

An old piston ring can be used to clean the piston ring groove.

- Check the piston rings for damage.
 - » If the piston ring is damaged:
 - Change the piston ring.



Info

Mount the piston ring with the marking facing upward.

- Check the piston pins for discoloration or signs of wear.
 - » If the piston pin shows severe discoloration/signs of wear:
 - Change the piston pin.
- Place the upper conrod bearing and piston pin in the connecting rod and check the seating for play.
 - » If the piston pin seating has excessive play:
 - Change the connecting rod, conrod bearing, and crank pin.

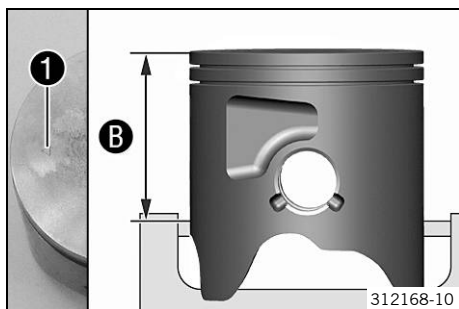

- Measure the piston at the piston skirt, at right angles to the piston pin, at a distance **B**.

Guideline

Distance B	50 mm (1.97 in)
Piston - diameter (All 250 models)	
Size I	66.340 ... 66.350 mm (2.61181 ... 2.6122 in)
Size II	66.351 ... 66.360 mm (2.61224 ... 2.61259 in)
Piston - diameter (All 300 models)	
Size I	71.940 ... 71.950 mm (2.83228 ... 2.83267 in)
Size II	71.951 ... 71.960 mm (2.83271 ... 2.83307 in)



Info

Piston dimensions **1** are marked on the piston head.



18.5.14 Checking the piston ring end gap

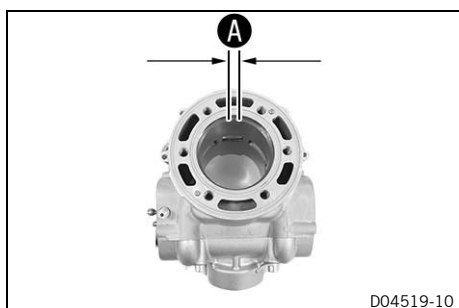

- Remove the piston ring from the piston.
- Place the piston ring in the cylinder and align with the piston.

Guideline

Below the upper edge of the cylinder	20 mm (0.79 in)
--------------------------------------	-----------------

- Measure end gap **A** with a feeler gauge.

Guideline

Piston ring - end gap	
Ring 1	≤ 0.40 mm (≤ 0.0157 in)
Ring 2	≤ 0.40 mm (≤ 0.0157 in)

- » If the end gap is greater than the specified value:
 - Check/measure the cylinder. (📖 p. 224)
- » If cylinder wear lies within the specified tolerance:
 - Change the piston ring.
- Mount the piston ring with the marking facing toward the piston head.



18.5.15 Measuring the piston/cylinder mounting clearance



- Check/measure the cylinder. (📖 p. 224)
- Check/measure the piston. (📖 p. 232)
- The smallest piston/cylinder mounting clearance equals the smallest cylinder bore diameter minus the largest piston diameter. The largest piston/cylinder mounting clearance equals the largest cylinder bore diameter minus the smallest piston diameter.

Guideline

Piston/cylinder - mounting clearance (All 250 models)	
New condition	0.050 ... 0.074 mm (0.00197 ... 0.00291 in)
Wear limit	0.10 mm (0.0039 in)
Piston/cylinder - mounting clearance (All 300 models)	
New condition	0.050 ... 0.085 mm (0.00197 ... 0.00335 in)
Wear limit	0.10 mm (0.0039 in)

18.5.16 Disassemble the reed valve housing

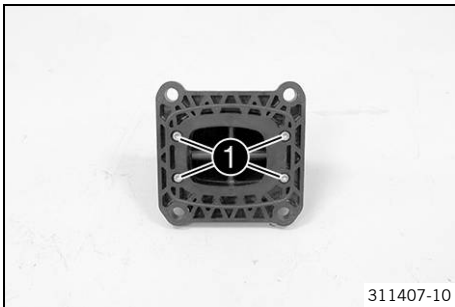

- Remove screws **1**.

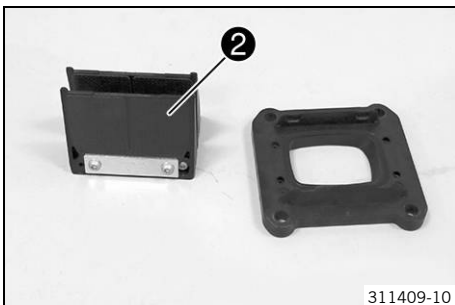

- Remove the reed valve housing **2** from the support plate.

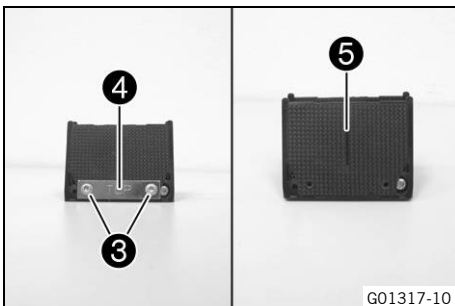

- Remove screws **3** on both sides.
- Take off clamping plate **4** on both sides.
- Remove the outer reed valve **5** on both sides.

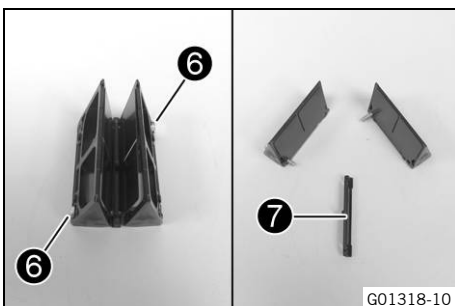

- Remove screws **6**.
- Separate the reed valve holders. Remove holding strip **7**.

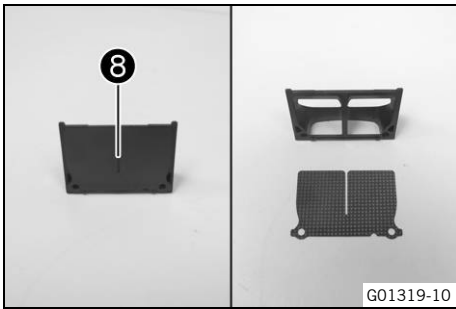

- Take off the inner reed valve **8** from both reed valve holders.



18.5.17 Checking the reed valve housing, reed valve and intake flange

Condition

Reed valve housing has been removed.

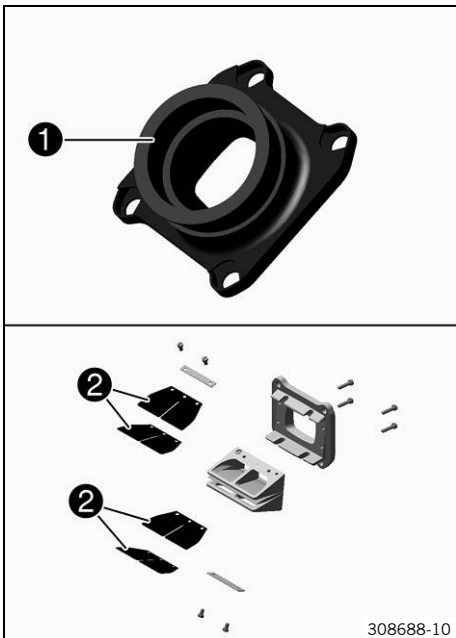

- Check intake flange **1** for damage and wear.
 - » If there is damage or wear:
 - Change the intake flange.
- Check reed valve **2** for damage and wear.
 - » If there is damage or wear:
 - Change the reed valve.
- Check the reed valve housing for damage and wear.
 - » If there is damage or wear:
 - Change the reed valve housing.



18.5.18 Assemble the reed valve housing

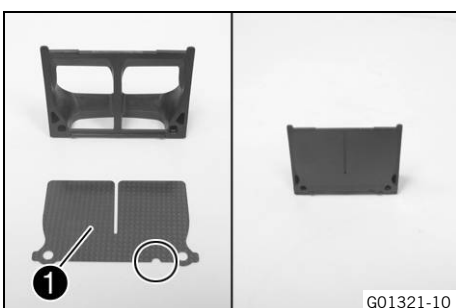

- Position the inner reed valve **1** on both reed valve holders.
 - ✓ The recesses are located on the right side.



- Position holding strip **2**.
- ✓ The pins engage in the drilled holes.

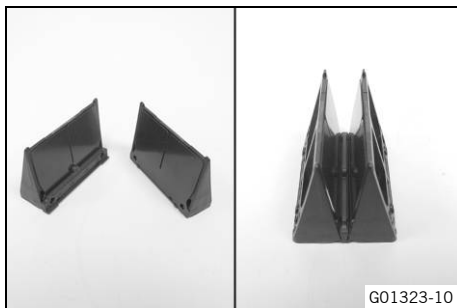

- Position the reed valve holders.

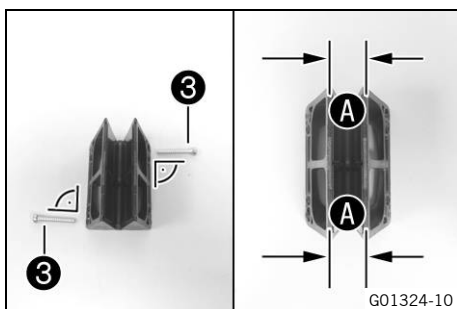

- Mount screws **3** and screw in all the way.



Info

Mount the screws at right angles to prevent damage.

- Loosen screws **3** and tighten again.

Guideline

Screw, inner membrane sheets	EJOTDELTA PT® 35x25	1 Nm (0.7 lbf ft)
------------------------------	-------------------------------	-------------------

- ✓ Distance **A** is equal on both sides.

- Position the outer reed valve **4** on both sides.

- ✓ The recesses are located on the right side.

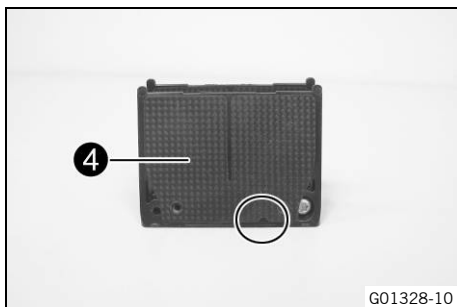

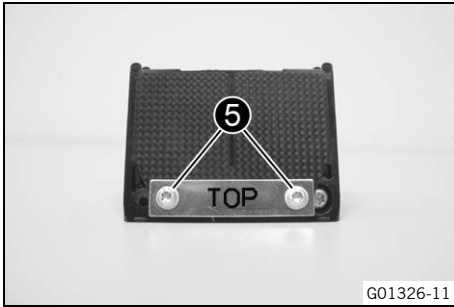

- Position the clamping plates on both sides.
- ✓ After installation, the **TOP** marking must be visible as shown.
- Mount screws **5** on both sides and screw in all the way.
- Loosen screws **5** and tighten again.

Guideline

Screw, outer membrane sheets	EJOTDELTA PT® 30x6	1 Nm (0.7 lbf ft)
------------------------------	------------------------------	-------------------



- Position gasket **6**.



- Position the reed valve housing in the support plate.
- ✓ The outer recess is located on the right in the direction of travel when installed.
- Mount and tighten screws **7**.

Guideline

Screw, membrane support plate	EJOTDELTA PT® 30x12	1 Nm (0.7 lbf ft)
-------------------------------	-------------------------------	-------------------

18.5.19 Working on the clutch cover



Info

Remove the outer clutch cover to avoid damage.

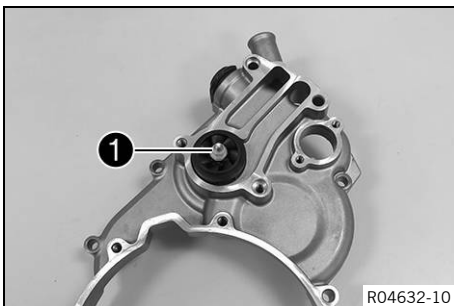

- Remove nut **1**.
- Take off the water pump impeller.

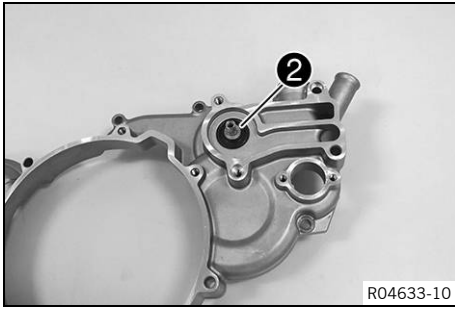

- Remove form washer **2**.

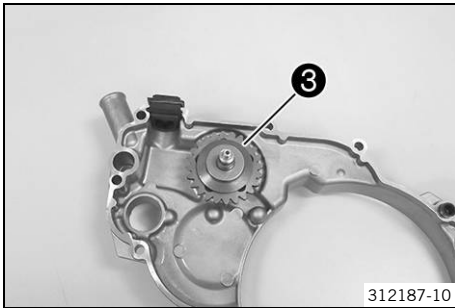

- Remove centrifugal timer **3**.

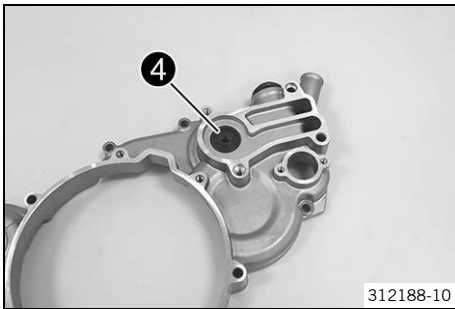

- Remove shaft seal ring **4**.

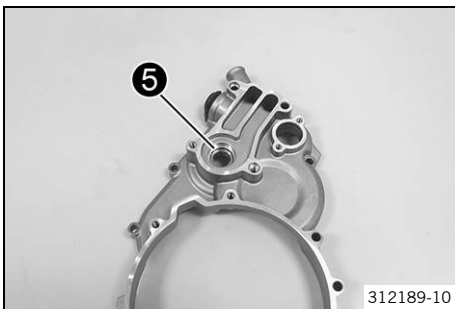

- Press out bearing **5** toward the inside.

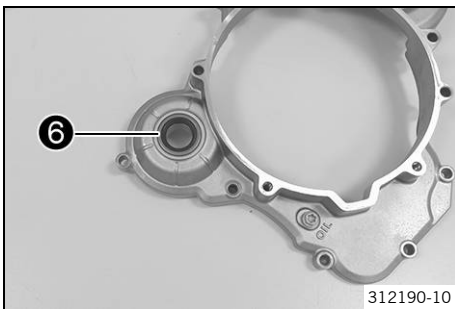

- Remove shaft seal ring **6**.
- Press in the new shaft seal ring all the way to the stop.

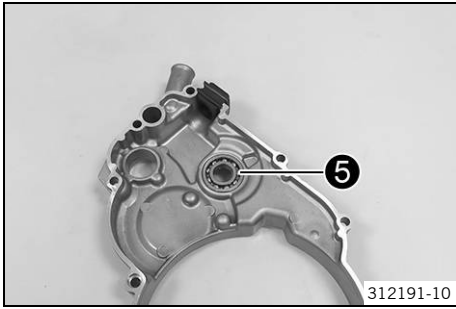

- Press bearing **5** all the way in to the stop from the inside.

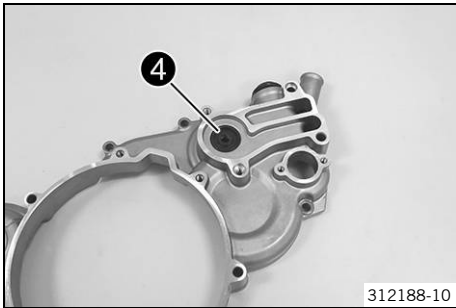

- Press shaft seal ring **4** so it is flush.
- Ensure that the bearing can turn freely and does not touch the shaft seal ring.

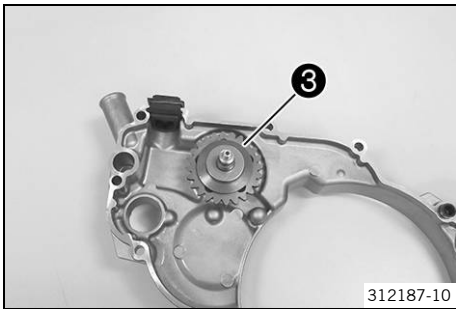

- Mount centrifugal timer **3**.

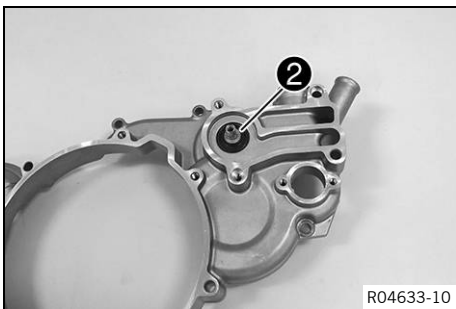

- Position form washer **2**.

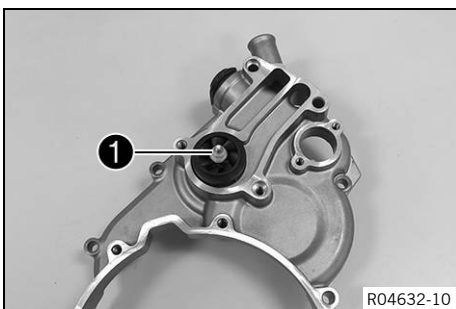

- Mount the water pump impeller.
- Mount and tighten nut **1**.

Guideline

Cap nut, water pump impeller	M6	6 Nm (4.4 lbf ft) Loctite®243™
------------------------------	----	--

18.5.20 Checking the clutch

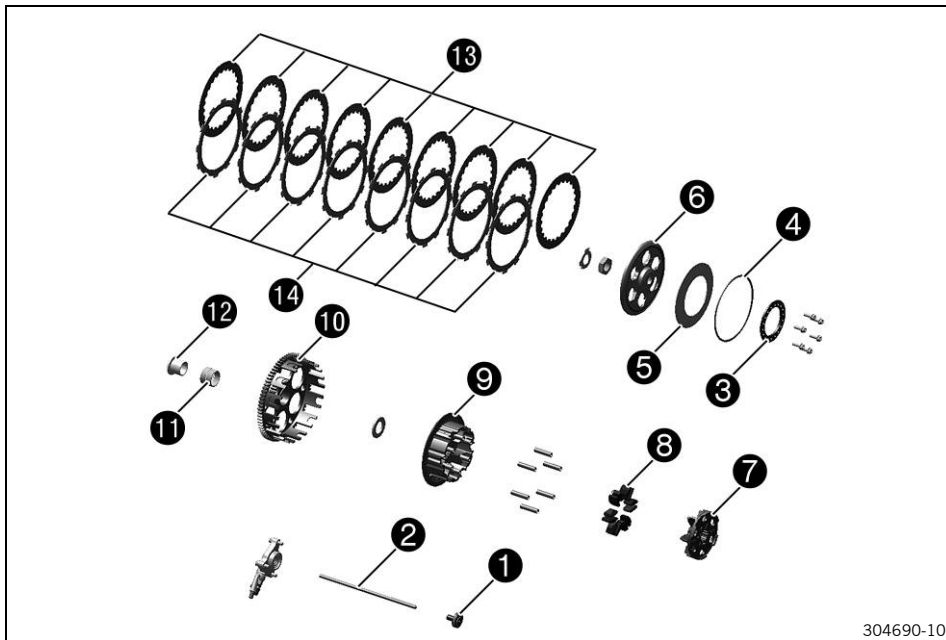

304690-10

- Check clutch push rod **1** for damage and wear.
 - » If there is damage or wear:
 - Change the clutch push rod.
- Place clutch push rod **2** on a flat surface and check for run-out.
 - » If there is run-out:
 - Change the clutch push rod.
- Check spring retainer **3** for damage and wear.
 - » If there is damage or wear:
 - Change the spring retainer.
- Check pretension ring **4** for damage and wear.
 - » If there is damage or wear:
 - Change the pretension ring.
- Check spring washer **5** for damage and wear.
 - » If there is damage or wear:
 - Change the spring washer.
- Check the contact surface of pressure cap **6** for damage and wear.
 - » If there is damage or wear:
 - Change the pressure cap.
- Check clutch center **7** for damage and wear.
 - » If there is damage or wear:
 - Change the clutch center.
- Check damping rubber pieces **8** for damage and wear.
 - » If there is damage or wear:
 - Change the damping rubber pieces.
- Check inner clutch hub **9** for damage and wear.
 - » If there is damage or wear:
 - Change the inner clutch hub.
- Check the thrust surfaces of the clutch facing discs in clutch basket **10** for damage and wear.

- » If there is damage or wear:
 - Change the clutch facing discs and the clutch basket.
- Check needle bearing **11** and collar sleeve **12** for damage and wear.
 - » If there is damage or wear:
 - Change the needle bearing and collar sleeve.
- Check intermediate discs **13** for damage and wear.
 - » If the intermediate discs are not flat or have punctiform outbreaks:
 - Change all intermediate discs.
- Check clutch facing discs **14** for discoloration and scoring.
 - » If there is discoloration or scoring:
 - Change all clutch facing discs.
- Check the thickness of clutch facing discs **14**.

Clutch facing disc - thickness	$\geq 1.9 \text{ mm } (\geq 0.075 \text{ in})$
--------------------------------	--

- » If the clutch facing disc does not meet specifications:
 - Change all clutch facing discs.



18.5.21 Preassembling shift shaft

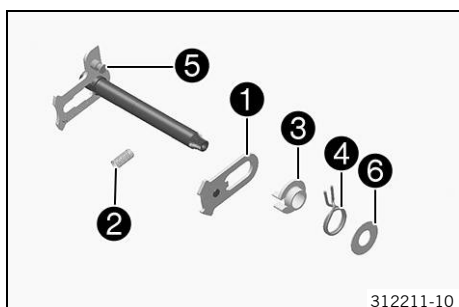

- Secure the short end of the shift shaft in the bench vise.

Guideline

Use soft jaws.

- Mount sliding plate **1** with the guide pin facing downward and put the guide pin on the shift quadrant.
- Mount pressure spring **2**.
- Slide on spring guide **3**, push return spring **4**, with the offset end facing upward, over the spring guide and lift the offset end over abutment bolt **5**.
- Mount stop disk **6**.



18.5.22 Checking the shift mechanism

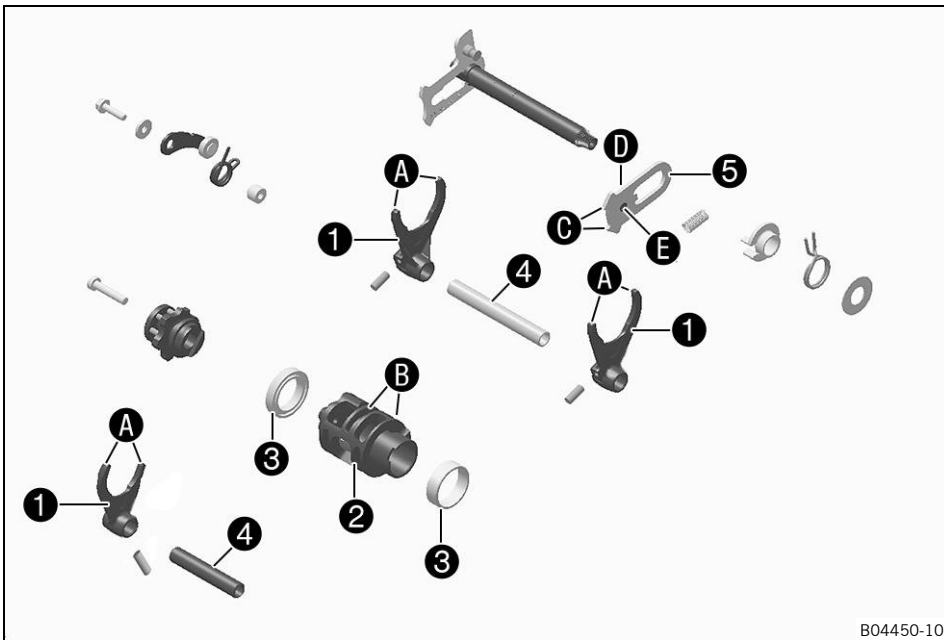

B04450-10

- Check shift forks **1** on plate **A** for damage and wear (visual check).
 - » If there is damage or wear:
 - Change the shift fork.
- Check shift grooves **B** of shift drum **2** for wear.
 - » If the shift groove is worn:
 - Change the shift drum.
- Check the seat of the shift drum in bearings **3**.
 - » If the shift drum is not seated correctly:
 - Change the shift drum and/or the bearing.
- Check bearing **3** for stiffness and wear.
 - » If the bearings do not move freely or are worn:
 - Change the bearings.
- Check the shift rollers for damage and wear.
 - » If there is damage or wear:
 - Change the shift rollers.
- Check shift rails **4** for run-out on a flat surface.
 - » If there is run-out:
 - Change the shift rail.
- Check the shift rails for scoring, wear and smooth operation in the shift forks.
 - » If there is scoring or corrosion, or if the shift fork is stiff:
 - Change the shift rail.
- Check sliding plate **5** in contact areas **C** for wear.
 - » If the sliding plate is worn:
 - Change the sliding plate.
- Check return surface **D** on the sliding plate for wear.
 - » If deep notches are present:
 - Change the sliding plate.
- Check guide pin **E** for looseness and wear.

- » If the guide pin is loose and/or worn:
 - Change the sliding plate.

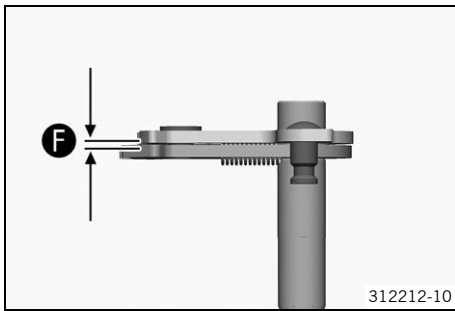

- Preassemble the shift shaft. (📖 p. 241)
- Check clearance **F** between the sliding plate and the shift quadrant.

Shift shaft - sliding plate/shift quadrant play	0.40 ... 0.80 mm (0.0157 ... 0.0315 in)
---	---

- » If the measured value does not meet specifications:
 - Change the sliding plate.



18.5.23 Disassembling the main shaft

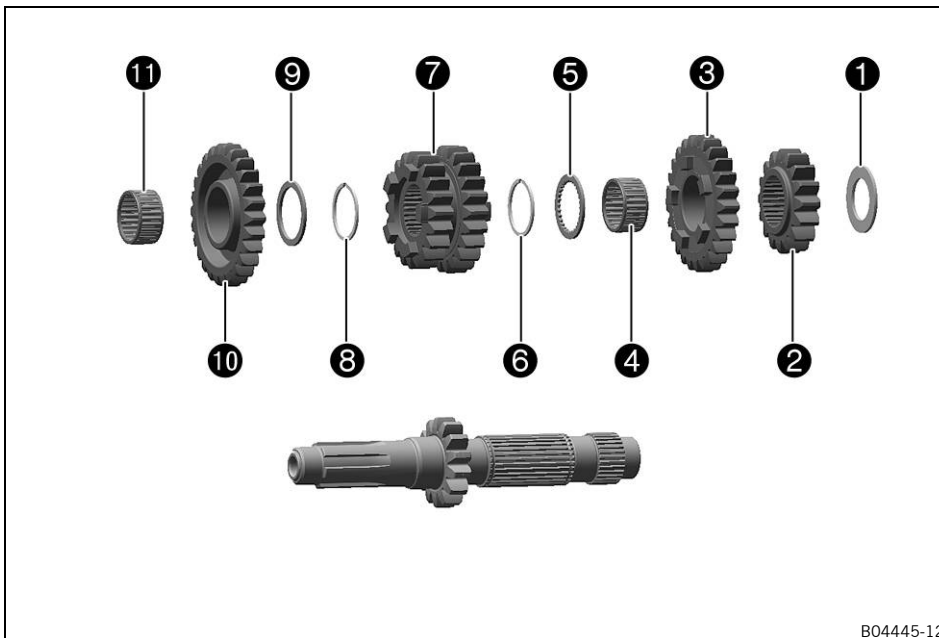

- Secure the main shaft with the toothed end facing downward in the vise.

Guideline

Use soft jaws.

- Remove stop disk **1** and second-gear fixed gear **2**.
- Remove fifth-gear idler gear **3** and needle bearing **4**.
- Remove stop disk **5**.
- Remove lock ring **6**.
- Remove third/fourth-gear sliding gear **7**.
- Remove lock ring **8**.
- Remove stop disk **9**.
- Remove sixth-gear idler gear **10**.
- Remove needle bearing **11**.



18.5.24 Disassembling the countershaft

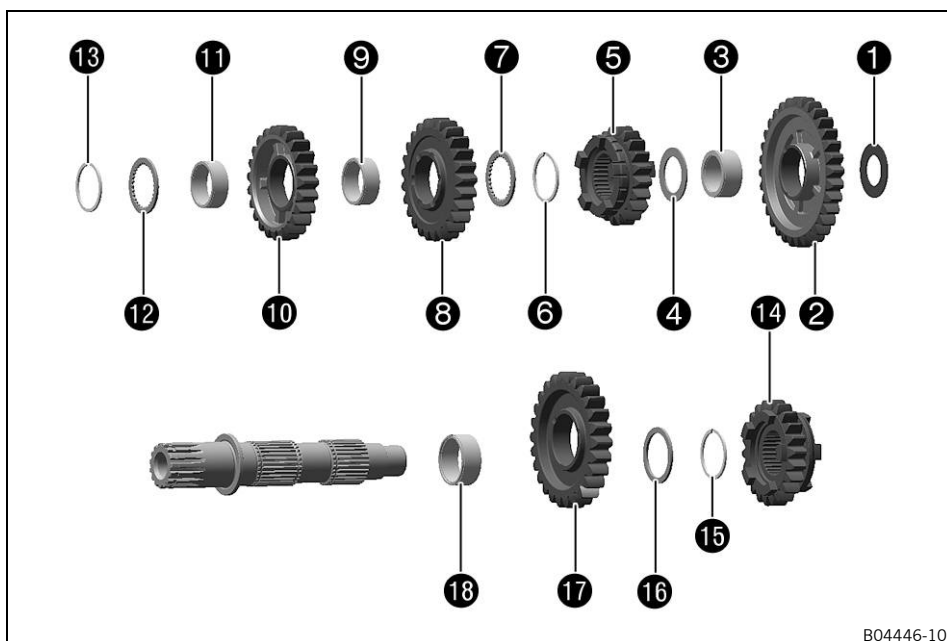

B04446-10

- Secure the countershaft in the bench vise with the toothed end facing downward.

Guideline

Use soft jaws.

- Remove stop disk ① and first-gear idler gear ②.
- Remove needle bearing ③ and stop disk ④.
- Remove sixth-gear sliding gear ⑤.
- Remove lock ring ⑥.
- Remove stop disk ⑦.
- Remove third-gear idler gear ⑧ and needle bearing ⑨.
- Remove fourth-gear idler gear ⑩.
- Remove needle bearing ⑪.
- Remove stop disk ⑫ and lock ring ⑬.
- Remove fifth-gear sliding gear ⑭.
- Remove lock ring ⑮.
- Remove stop disk ⑯.
- Remove second-gear idler gear ⑰ and needle bearing ⑱.

18.5.25 Checking the transmission

Condition

The transmission has been disassembled.

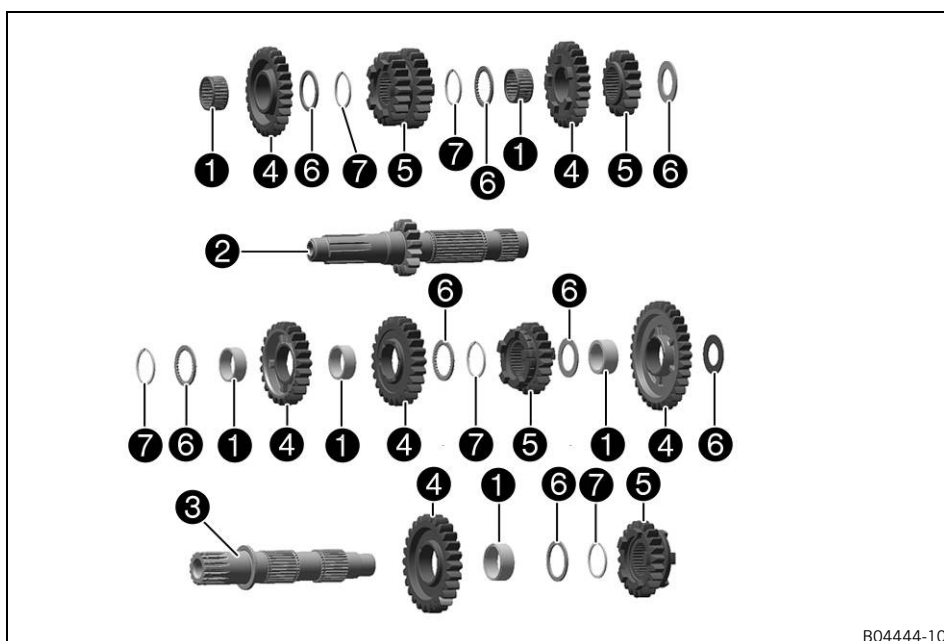

B04444-10

- Check needle bearings **1** for damage and wear.
 - » If there is damage or wear:
 - Change the needle bearings.
- Check the pivot points of main shaft **2** and countershaft **3** for damage and wear.
 - » If there is damage or wear:
 - Change the main shaft and/or countershaft.
- Check the tooth profiles of main shaft **2** and countershaft **3** for damage and wear.
 - » If there is damage or wear:
 - Change the main shaft and/or countershaft.
- Check the pivot points of idler gears **4** for damage and wear.
 - » If there is damage or wear:
 - Change the gear wheel pair.
- Check the shift dogs of idler gears **4** and sliding gears **5** for damage and wear.
 - » If there is damage or wear:
 - Change the gear wheel pair.
- Check the tooth faces of idler gears **4**, sliding gears **5**, and fixed gear **6** for damage and wear.
 - » If there is damage or wear:
 - Change the gear wheel pair.
- Check the tooth profiles of sliding gears **5** for damage and wear.
 - » If there is damage or wear:
 - Change the gear wheel pair.
- Check sliding gears **5** for smooth operation in the profile of main shaft **2**.
 - » If the sliding gear does not move freely:
 - Change the sliding gear or the main shaft.
- Check sliding gears **5** for smooth operation in the profile of countershaft **3**.
 - » If the sliding gear does not move freely:
 - Change the sliding gear or the countershaft.
- Check stop disks **7** for damage and wear.
 - » If there is damage or wear:
 - Change the stop disks.

- Use new lock rings **8** with every repair.

18.5.26 Assembling the main shaft

i Info

Use new lock rings with every repair.

Preparatory work

- Check the transmission. (🔊 p. 244)
- Carefully lubricate all parts before assembling.

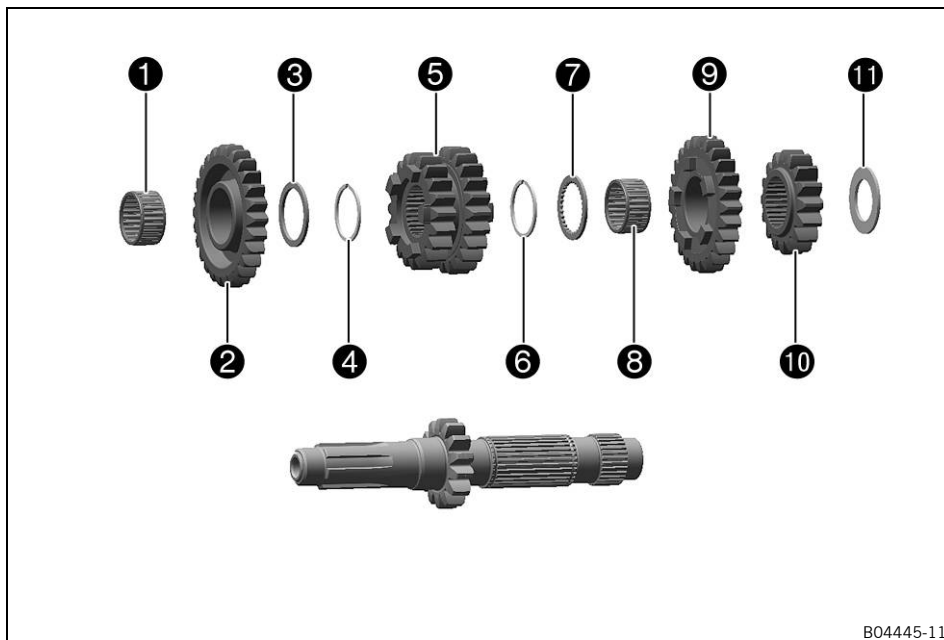

B04445-11

Main work

- Secure the main shaft in the vise with the gear teeth facing downward.

Guideline

Use soft jaws.

- Mount needle bearing **1**.
- Mount sixth-gear idler gear **2**.
- Mount stop disk **3** and lock ring **4**.
- Mount third/fourth-gear sliding gear **5**.
- Mount lock ring **6** and stop disk **7**.
- Mount needle bearing **8**.
- Mount fifth-gear idler gear **9**.
- Mount second-gear fixed gear **10** and stop disk **11**.
- Finally, check all the gear wheels for smooth operation.

18.5.27 Assembling the countershaft

i Info

Use new lock rings with every repair.

Preparatory work

- Check the transmission. (📖 p. 244)
- Carefully lubricate all parts before assembling.

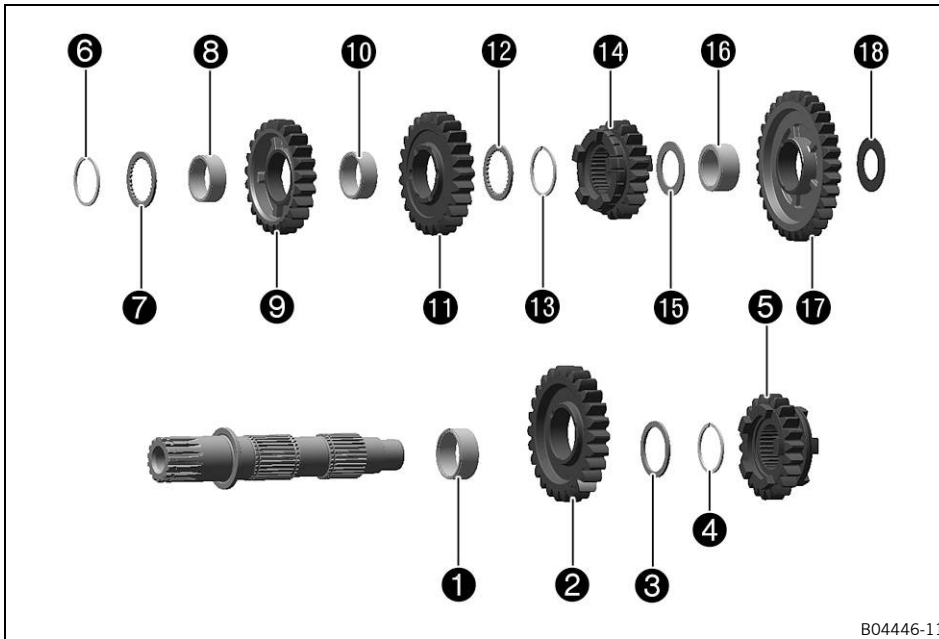

B04446-11

Main work

- Secure the countershaft in the bench vise with the toothed end facing downward.

Guideline

Use soft jaws.

- Mount needle bearing **1** and second-gear idler gear **2** onto the countershaft with the protruding collar facing downward.
- Mount stop disk **3** and lock ring **4**.
- Mount fifth-gear sliding gear **5** with the shift groove facing up.
- Mount lock ring **6** and stop disk **7**.
- Mount needle bearing **8** and fourth-gear idler gear **9**.
- Mount needle bearing **10**.
- Mount third-gear idler gear **11**.
- Mount stop disk **12** and lock ring **13**.
- Mount sixth-gear sliding gear **14** with the shift groove facing downward.
- Mount stop disk **15**.
- Mount needle bearing **16** and first-gear idler gear **17**.
- Mount stop disk **18**.
- Finally, check all the gear wheels for smooth operation.



18.5.28 Checking the kick starter

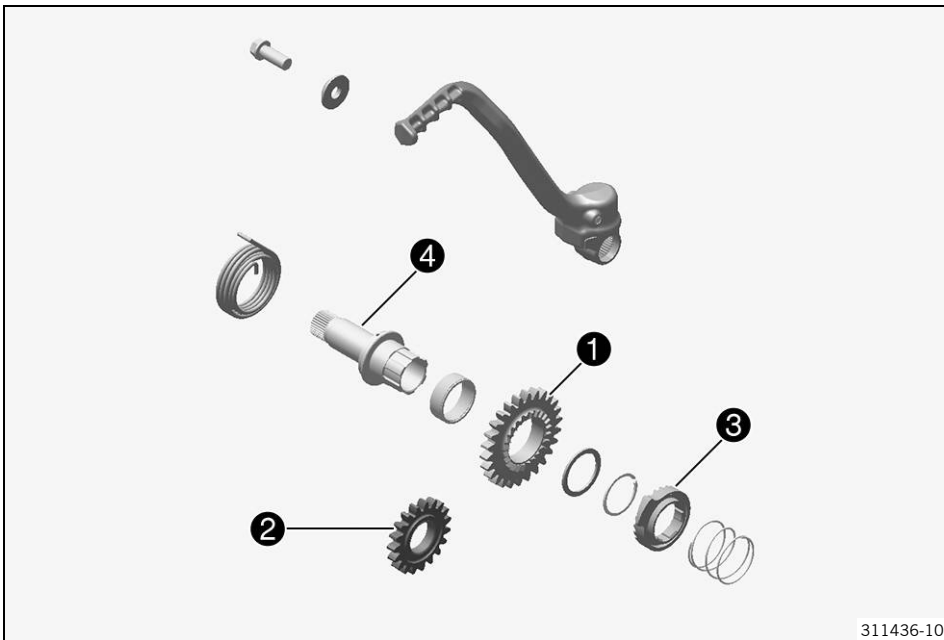

311436-10

- Check the gear teeth and bearing of kick starter gear **1** for damage and wear.
 - » If there is damage or wear:
 - Change the kick starter gear.
- Check the gear teeth and bearing of intermediate kick starter gear **2** for damage and wear.
 - » If there is damage or wear:
 - Change the intermediate kick starter gear.
- Check the gear teeth and contact surface of kick starter ratchet wheel **3** for damage and wear.
 - » If there is damage or wear:
 - Change the kick starter ratchet wheel.
- Check the gear teeth and bearing of kick starter shaft **4** for damage and wear.
 - » If there is damage or wear:
 - Change the kick starter shaft.

18.5.29 Preassembling the kick starter shaft

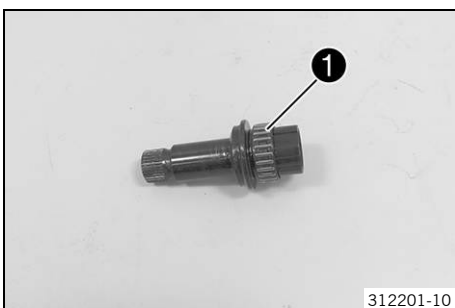

312201-10

- Mount bearing **1**.

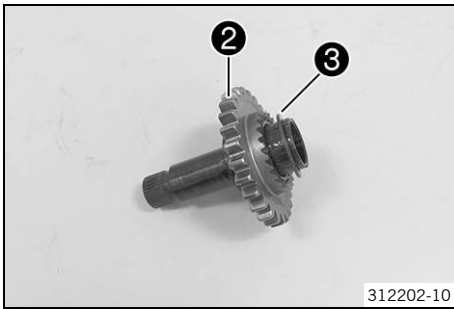

- Mount kick starter gear ② with washer ③.

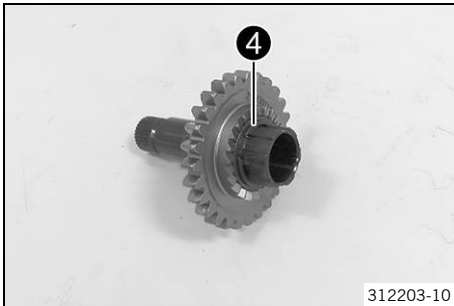

- Mount lock ring ④.

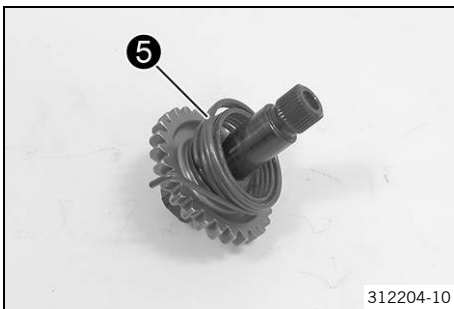

- Mount kick starter spring ⑤.
✓ The end of the kick starter spring engages in the hole.

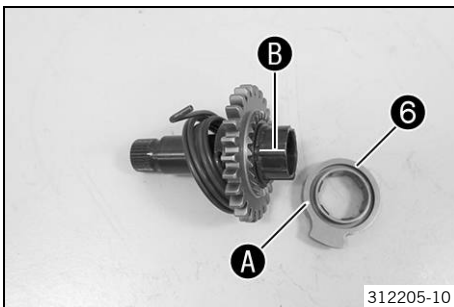

- Mount kick starter ratchet wheel ⑥.
✓ Align markings ① and ②.

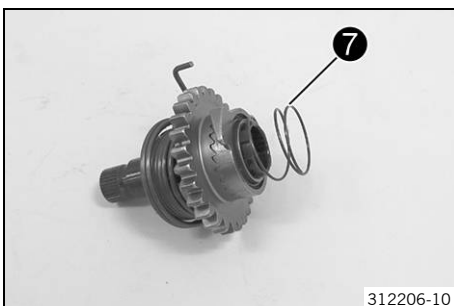

- Mount spring ⑦.

18.5.30 Checking the electric starter drive

Condition

Bendix has been removed.

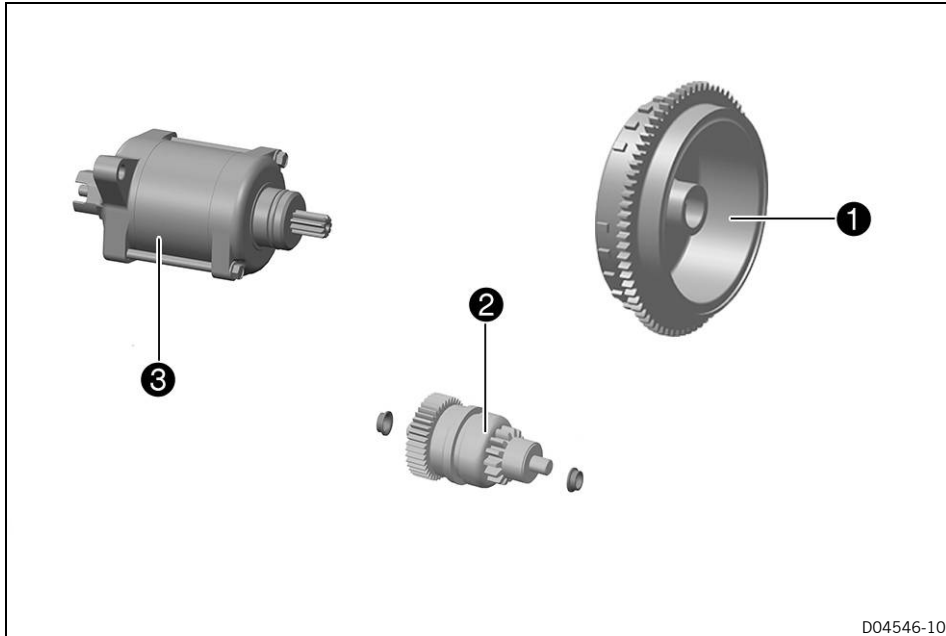

D04546-10

- Check the gear teeth of rotor **1** for damage and wear.
 - » If there is damage or wear:
 - Change the rotor.
- Check the gear teeth and bearing of the Bendix **2** for smooth operation, damage, and wear.
 - » If damaged or worn, or if the Bendix does not move easily:
 - Change the Bendix.
- Check the gear mesh of starter motor **3** for damage and wear.
 - » If there is damage or wear:
 - Change the starter motor.
- Connect the negative cable of a 12-volt power supply to the housing of the starter motor. Connect the positive cable of the power supply briefly with the connector of the starter motor.
 - » If the starter motor does not turn when the circuit is closed:
 - Change the starter motor.

18.6 Engine assembly

18.6.1 Installing the crankshaft

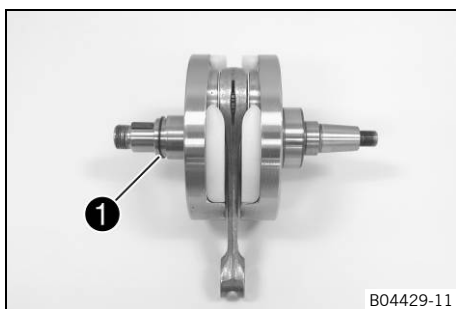

B04429-11

- Mount O-ring **1**.

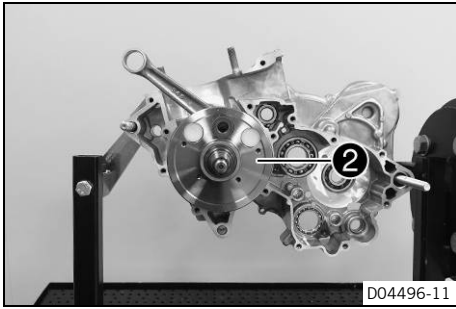

- Position the right section of the engine case in the engine work stand.

Engine work stand (61229001000) (📖 p. 370)

Holder and fitting for work stand (55429002000)
(📖 p. 365)

- Warm up the crankshaft bearing.

Guideline

100 °C (212 °F)

- Slide crankshaft **2** all the way into the bearing seat of the right section of the engine case.



18.6.2 Installing the transmission shafts

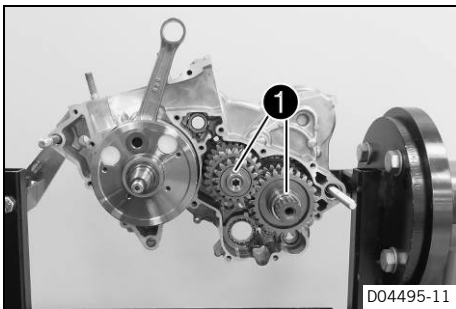

- Oil all bearings.

Engine oil (15W/50) (📖 p. 358)

- Assemble the two transmission shafts **1** and slide them into the bearing seats together.

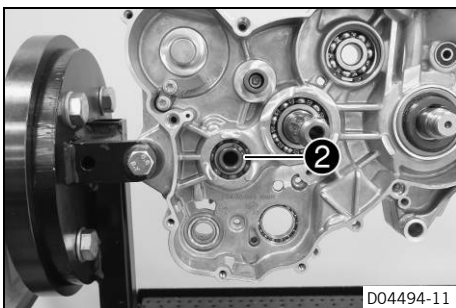

- Mount lock ring **2**.



18.6.3 Installing the shift forks

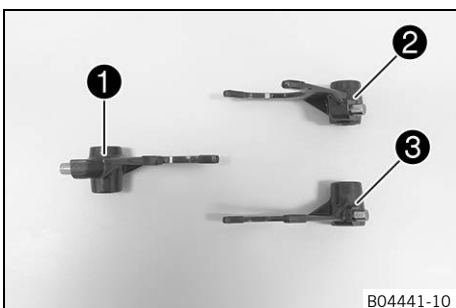

- Arrange shift forks **1**, **2**, and **3** as shown.

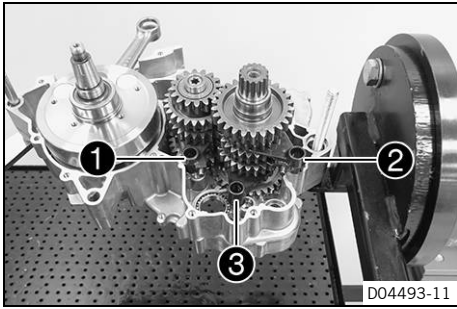

- Position shift forks **1**, **2**, and **3** in the sliding gears.

18.6.4 Installing the shift drum

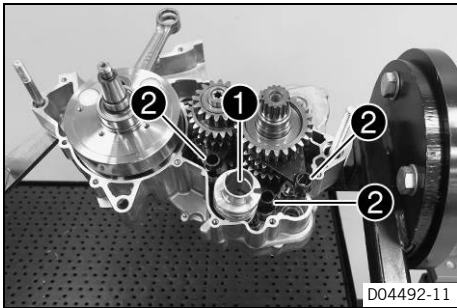

- Push shift drum **1** into the bearing seat.
- Position shift forks **2** in the shift grooves.



Info

Do not misplace the shift rollers.

18.6.5 Installing the shift rails

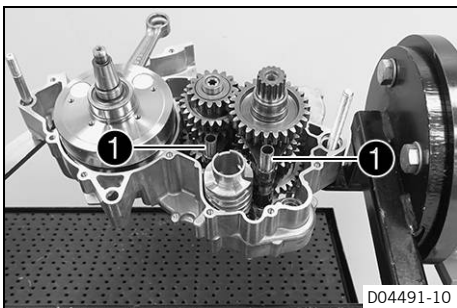

- Mount shift rails **1**.

18.6.6 Installing the left engine case section

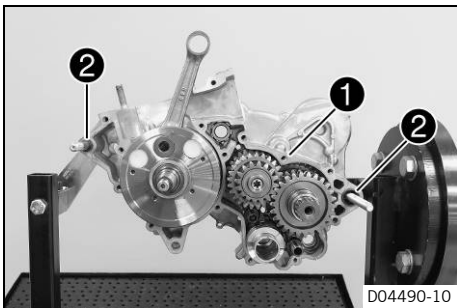

- Coat the sealing area thinly with grease.
- Mount engine case gasket **1**.
- Check that dowels **2** are seated correctly.

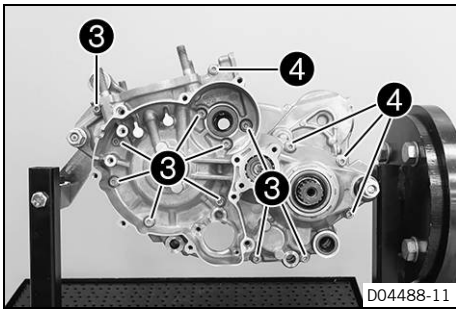

- Mount the left section of the engine case.



Info

Do not use the screws to pull the two sections of the engine case together.

- Mount screws 3 and, once all screws of the left section of the engine case have been mounted, tighten.

Guideline

Screw, engine case	M6x45	10 Nm (7.4 lbf ft)
--------------------	-------	--------------------

- Mount screws 4 and, once all screws of the left section of the engine case have been mounted, tighten.

Guideline

Screw, engine case	M6x60	10 Nm (7.4 lbf ft)
--------------------	-------	--------------------

- Fix the engine in the engine work stand.
- Remove the excess lengths of the engine case gasket in the area of the cylinder support and the reed valve housing.

- Grease the shaft seal ring and mount distance sleeve 5.

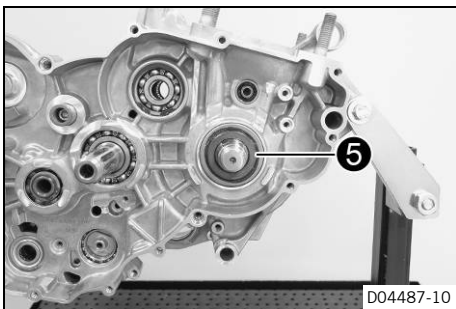

18.6.7 Installing the reed valve housing

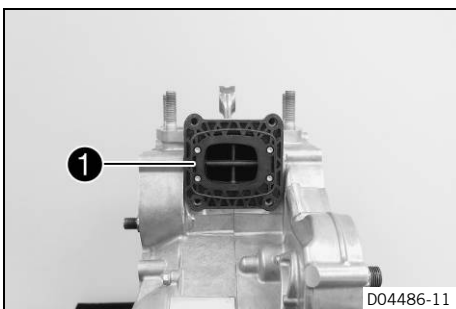

- Position the gasket.
- Position reed valve housing 1 in the engine case opening.

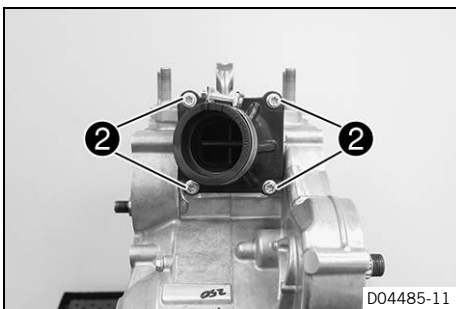

- Position the intake flange with the gasket.
- Mount and tighten screws 2.

Guideline

Screw, intake flange/reed valve housing	M6	6 Nm (4.4 lbf ft)
---	----	-------------------

18.6.8 Installing the starter motor

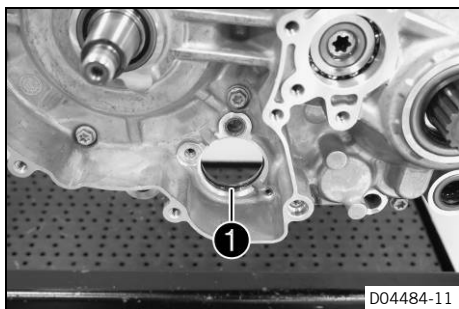

- Grease and mount O-ring ①.

Long-life grease (🗨️ p. 360)

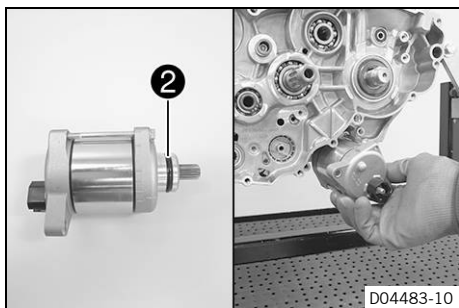

- Grease O-ring ②.

Long-life grease (🗨️ p. 360)

- Position the starter motor in the engine case.

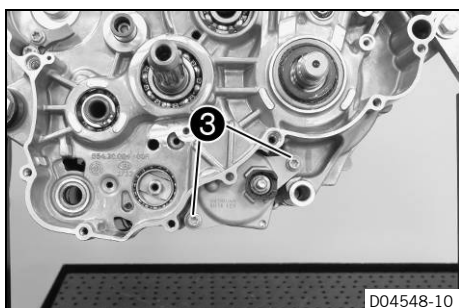

- Mount screws ③ but do not tighten yet.

Guideline

Screw, starter motor	M6	10 Nm (7.4 lbf ft)
----------------------	----	--------------------

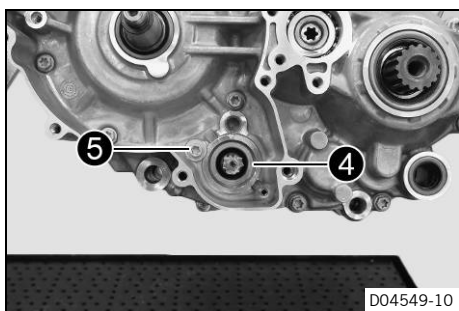

- Mount spacer ④ flush in the engine case.

- Mount and tighten screw ⑤.

Guideline

Screw, starter motor bearing bush	M6	10 Nm (7.4 lbf ft) Loctite®243™
-----------------------------------	----	---

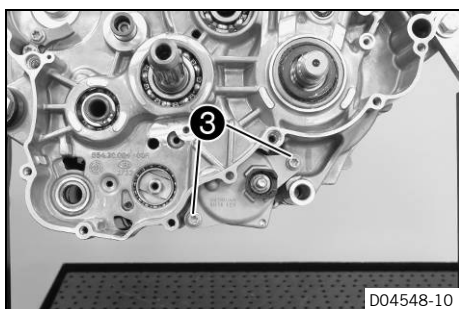

- Tighten screws ③.

Guideline

Screw, starter motor	M6	10 Nm (7.4 lbf ft)
----------------------	----	--------------------

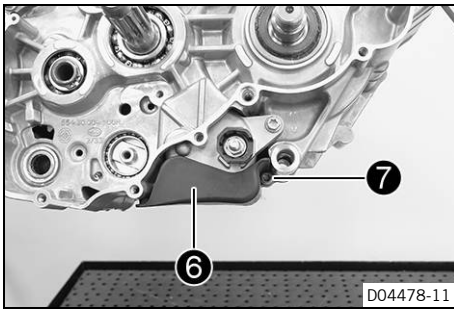

- Position cover **6**.
- Mount and tighten screw **7**.

Guideline

Screw, starter motor protection cap	M6	8 Nm (5.9 lbf ft)
-------------------------------------	----	-------------------

18.6.9 Installing the rotor

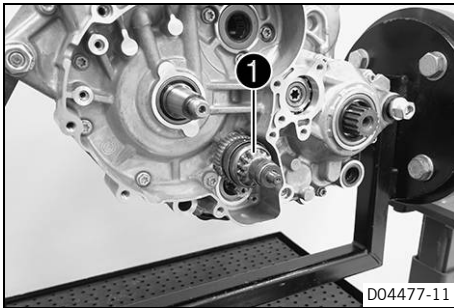

- Grease and mount Bendix **1**.

Lubricant (T625) (📖 p. 360)

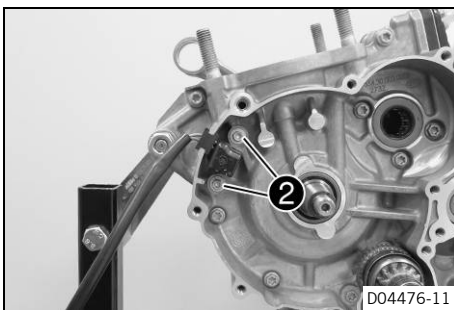

- Position the crankshaft position sensor.
- Mount and tighten screws **2**.

Guideline

Screw, crankshaft position sensor	M5	6 Nm (4.4 lbf ft) Loctite®243™
-----------------------------------	----	--

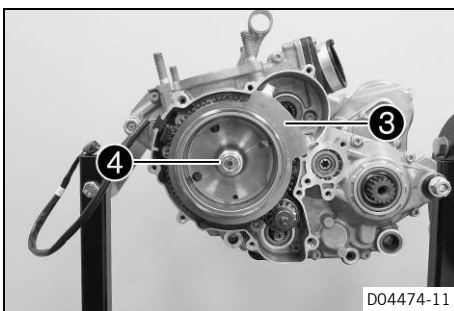

- Ensure that the woodruff key is seated properly.
- Grease the cone.
- Mount the rotor and hold it with special tool **3**.

Holding wrench (54629012200) (📖 p. 364)

- Mount washer and nut **4**. Tighten the nut.

Guideline

Nut, rotor	M12x1	60 Nm (44.3 lbf ft)
------------	-------	---------------------

18.6.10 Installing the locking lever

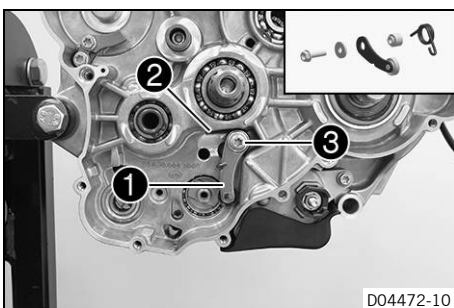

- Position locking lever **1** with the sleeve and spring **2**.
- Mount and tighten screw **3** with the washer.

Guideline

Screw, locking lever	M5	6 Nm (4.4 lbf ft) Loctite®243™
----------------------	----	--

18.6.11 Installing the shift drum locating unit

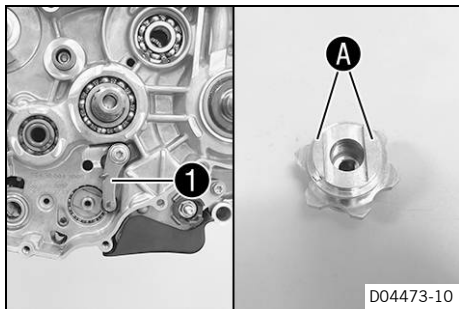

- Press locking lever **1** to the left and position the shift drum locating unit.



Info

The flat surfaces **A** of the shift drum locating unit are not symmetric.

- Relieve tension from the locking lever.

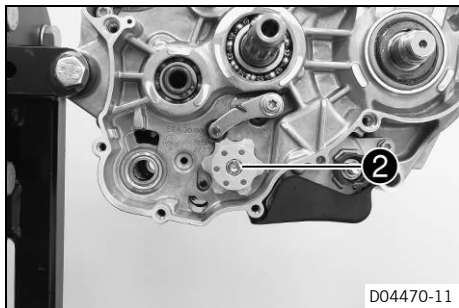

- Mount and tighten screw **2**.

Guideline

Screw, shift drum locating	M6	10 Nm (7.4 lbf ft) Loctite®243™
----------------------------	----	---

18.6.12 Installing the shift shaft

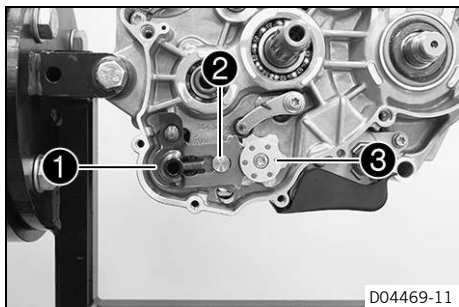

- Slide shift shaft **1** with the washer into the bearing seat.
- Push sliding plate **2** away from shift drum locating unit **3**. Insert the shift shaft all the way.
- Let the sliding plate engage in the shift drum locating unit.
- Shift through the transmission.

18.6.13 Installing the intermediate kick starter gear

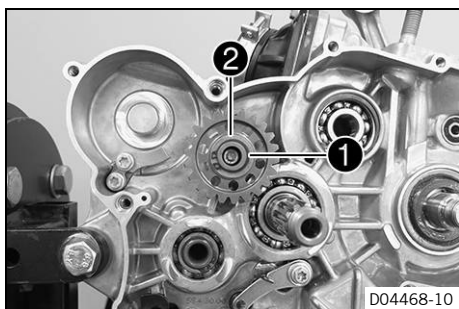

- Mount intermediate kick starter gear.
- Mount lock ring **1** with washer **2**.

18.6.14 Installing the kick starter shaft

Preparatory work

- Preassemble the kick starter shaft. (📖 p. 248)

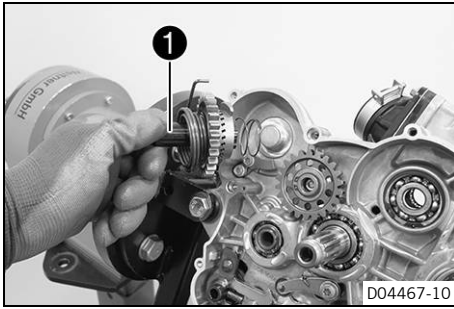

Main work

- Mount preassembled kick starter shaft ①.

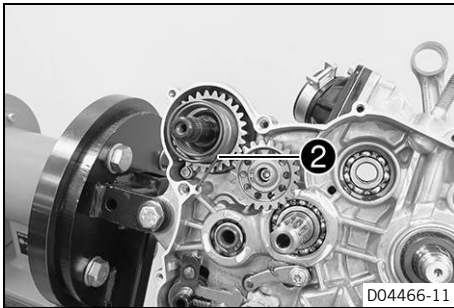

- Tension and attach kick starter spring ②.



Info

Ensure that the distance from the kick starter spring to the kick starter shaft is the same all around.

18.6.15 Installing the balancer shaft

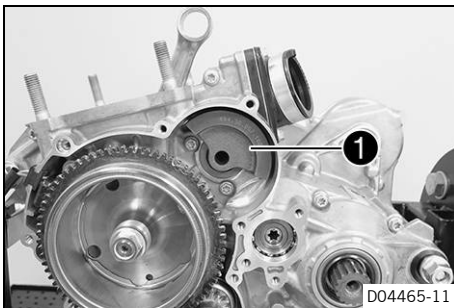

- Mount balancer shaft ①.

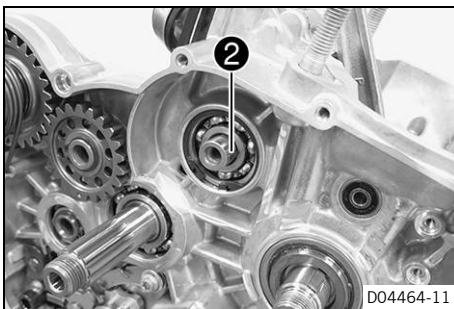

- Mount woodruff key ②.

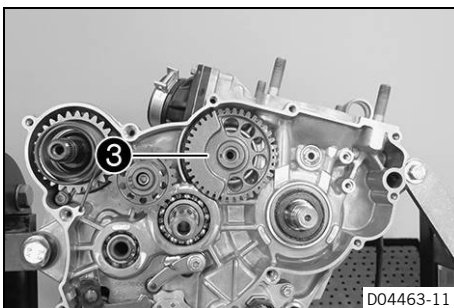

- Mount balancer shaft drive wheel ③.

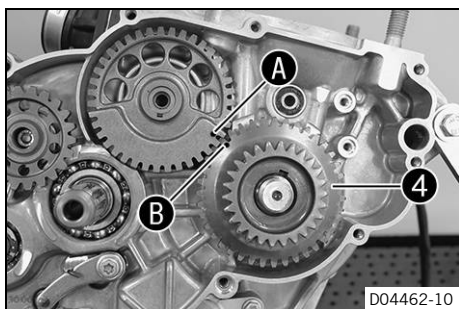

- Mount primary gear 4.
- ✓ Align markings A and B.

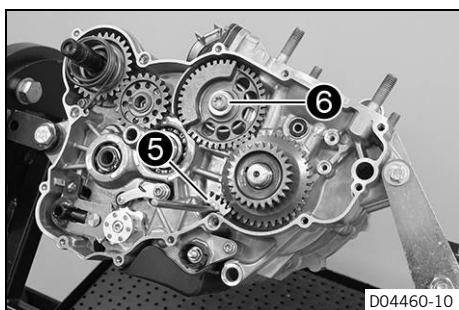

- Hold the primary gear using special tool 5.
- Mount and tighten screw 6 with the washer.

Gear segment (56012004000) (📖 p. 366)

Guideline		
Screw, balancer shaft	M8	30 Nm (22.1 lbf ft) Loctite®243™

i Info
Use a new screw for every repair.

18.6.16 Installing the clutch basket

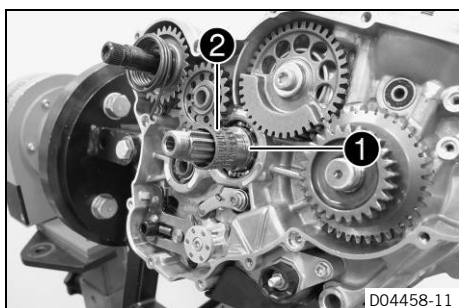

- Mount collar bushing 1.
- Oil and mount needle bearing 2.

Engine oil (15W/50) (📖 p. 358)

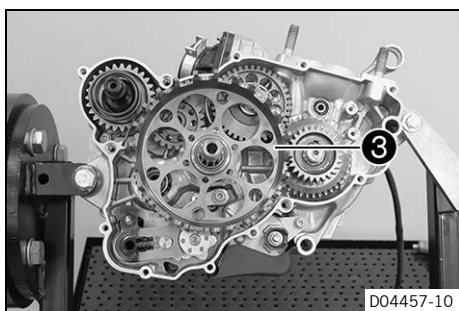

- Slide clutch basket 3 onto the gearbox main shaft.

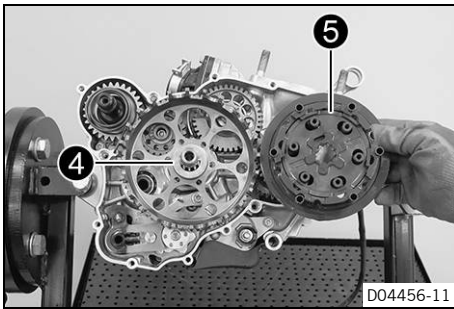

- Slide on washer 4 and inner clutch hub 5.

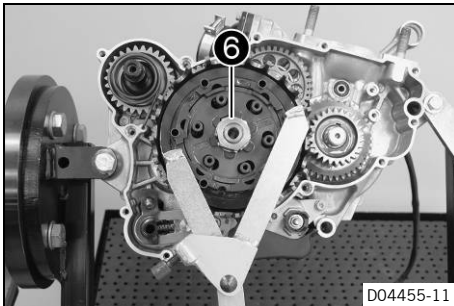

- Position the new lock washer and mount nut 6. Tighten the nut, holding the inner clutch hub with a special tool.

Guideline

Nut, inner clutch hub	M18x1.5	100 Nm (73.8 lbf ft) Loctite® 648™
-----------------------	---------	--

Holding wrench (51129003000) (📖 p. 364)

- Secure the nut with the lock washer.

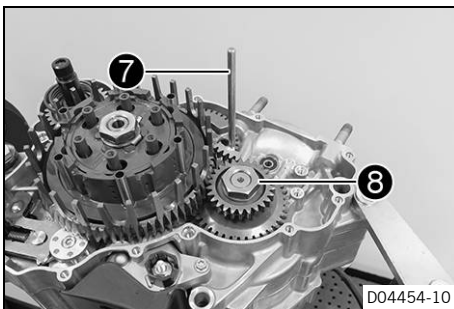

- Hold the primary gear using special tool 7.

Gear segment (56012004000) (📖 p. 366)

- Mount and tighten nut 8 with the washer.

Guideline

Nut, primary gear	M18LHx1.5	150 Nm (110.6 lbf ft) Loctite® 648™
-------------------	-----------	---

- Crank the engine to ensure that it can move easily.

18.6.17 Installing the clutch discs

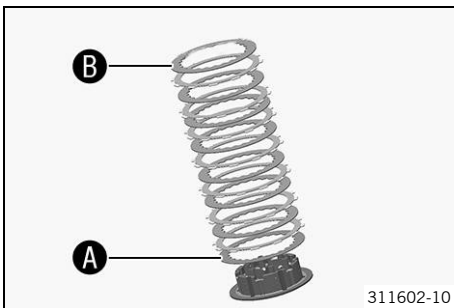

- Thoroughly oil the clutch facing discs.
- Mount intermediate clutch disc A with marking S.

Guideline

Thickness of intermediate clutch disc A	1.0 mm (0.039 in)
---	-------------------

- Alternately place the clutch facing and 7 intermediate discs into the clutch basket.

Guideline

Thickness of intermediate clutch discs	1.4 mm (0.055 in)
--	-------------------

- Place intermediate clutch disc B into the clutch basket.

Guideline

Thickness of intermediate clutch disc B	1.0 mm (0.039 in)
---	-------------------

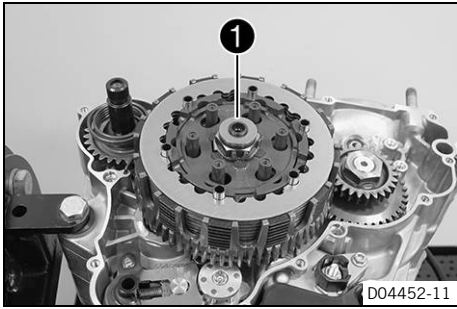

- Mount clutch throw-out **1**.

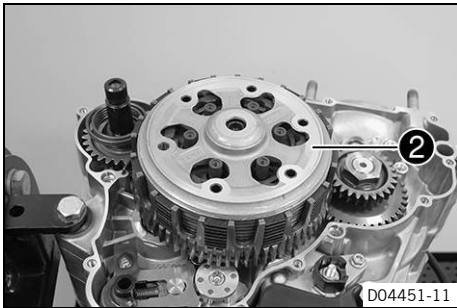

- Position pressure cap **2**.

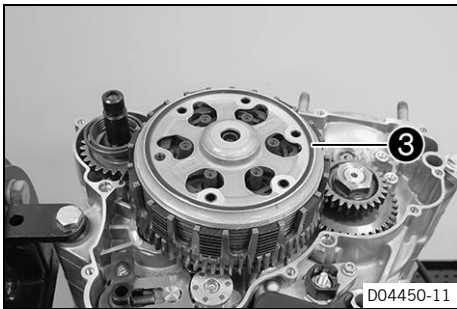

- Mount pretension ring **3** with marking **Top** facing up.

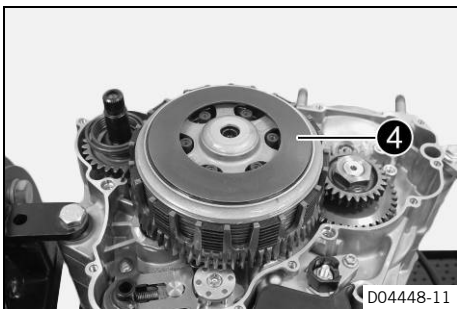

- Position spring washer **4**.

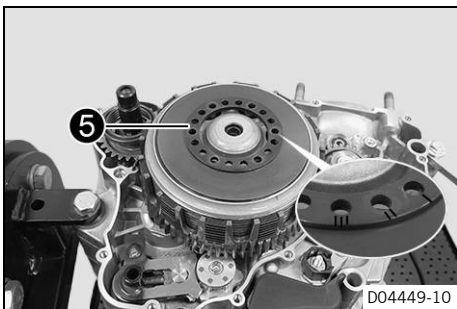

- Position spring retainer **5** with marking **I**.

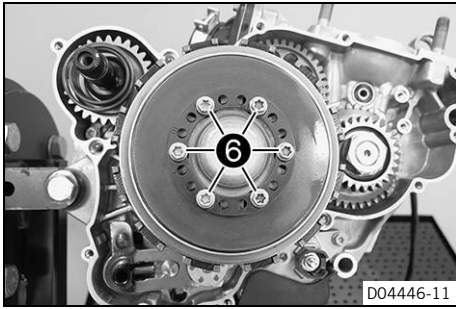

- Mount screws 6 and tighten in a crisscross pattern.

Guideline

Screw, clutch spring retainer	M5	6 Nm (4.4 lbf ft)
-------------------------------	----	-------------------

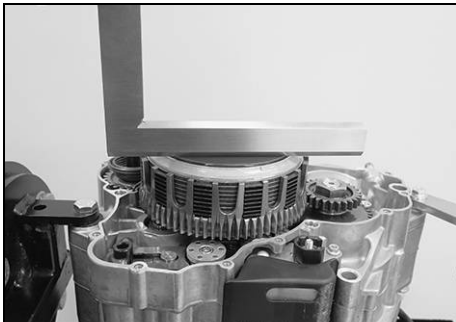

- Using a straightedge and the special tool, check the spring washer for distortion.

Feeler gauge (59029041100) (p. 369)		
-------------------------------------	--	--

Spring washer distortion	0 ... 0.10 mm (0 ... 0.0039 in)	
--------------------------	---------------------------------	--

- » If the specified value is not reached:
 - Remove screws 6 and mount the spring retainer with marking II.

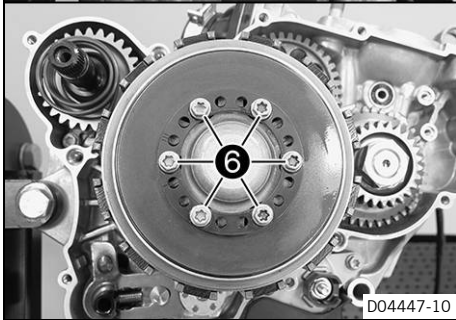

- Using a straightedge and the special tool, check the spring washer for distortion.

Feeler gauge (59029041100) (p. 369)		
-------------------------------------	--	--

Spring washer distortion	0 ... 0.10 mm (0 ... 0.0039 in)	
--------------------------	---------------------------------	--

- » If the specified value is not reached:
 - Remove screws 6 and mount the spring retainer with marking III.

- Using a straightedge and the special tool, check the spring washer for distortion.

Feeler gauge (59029041100) (p. 369)		
-------------------------------------	--	--

Spring washer distortion	0 ... 0.10 mm (0 ... 0.0039 in)	
--------------------------	---------------------------------	--

- » If the specified value is not reached:
 - Change the clutch facing discs.

18.6.18 Installing the clutch cover

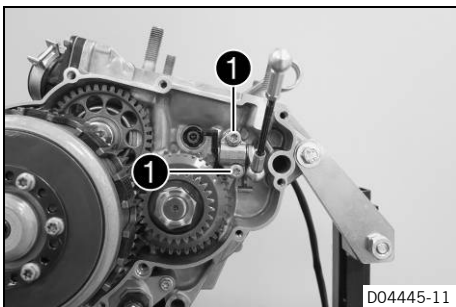

- Position the bearing support with the angle lever and linkage.
- Mount and tighten screws 1.

Guideline

Screw, exhaust control bearing support	M5	6 Nm (4.4 lbf ft) Loctite®243™
--	----	--

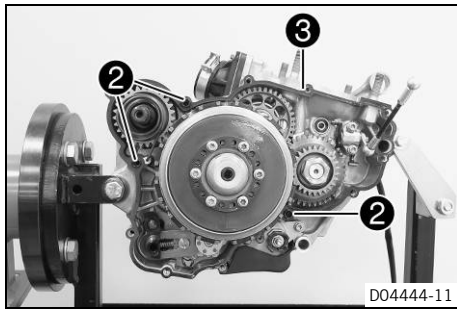

- Mount dowels **2**.
- Mount clutch cover gasket **3**.

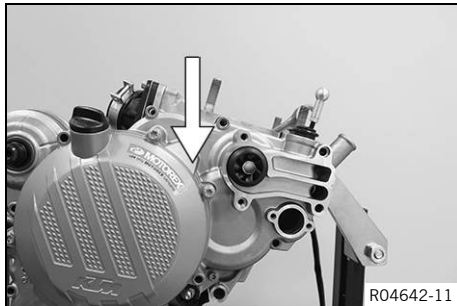

- Position the clutch cover and thread in the linkage.

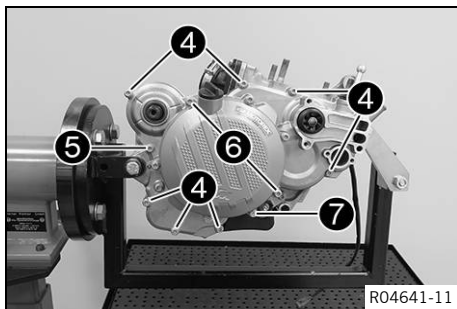

- Mount screws **4** but do not tighten yet.

Guideline

Screw, intermediate clutch cover	M6x25	10 Nm (7.4 lbf ft)
----------------------------------	-------	--------------------

- Mount screw **5** but do not tighten yet.

Guideline

Screw, intermediate clutch cover	M6x30	10 Nm (7.4 lbf ft)
----------------------------------	-------	--------------------

- Mount screws **6** but do not tighten yet.

Guideline

Screw, intermediate clutch cover	M6x60	10 Nm (7.4 lbf ft)
----------------------------------	-------	--------------------

- Mount screw **7** and tighten all screws in a crisscross pattern.

Guideline

Screw, intermediate clutch cover	M6x55	10 Nm (7.4 lbf ft)
----------------------------------	-------	--------------------

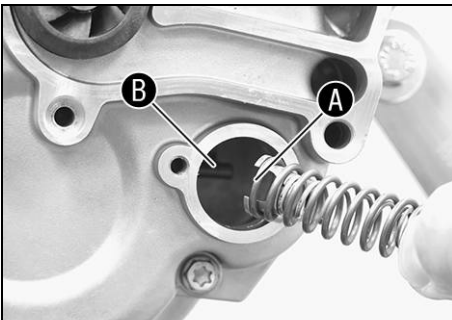

- Mount adjusting spring **8** with the auxiliary spring and spring insert.
- ✓ The recess **A** in the spring insert engages in angle lever **B**.

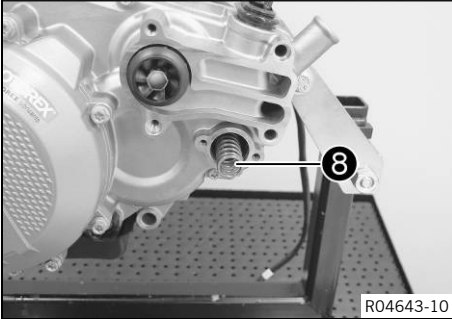

R04643-10

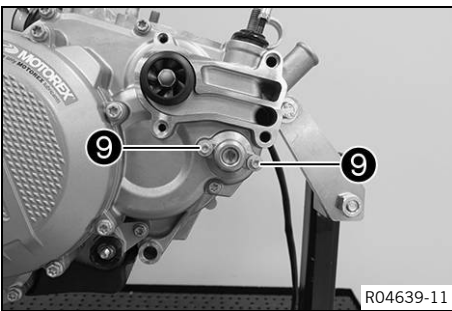

R04639-11

- Position the cap.
- Mount and tighten screws **9**.

Guideline

Screw, exhaust control cap	M5	5 Nm (3.7 lbf ft)
----------------------------	----	-------------------

18.6.19 Installing the water pump cover

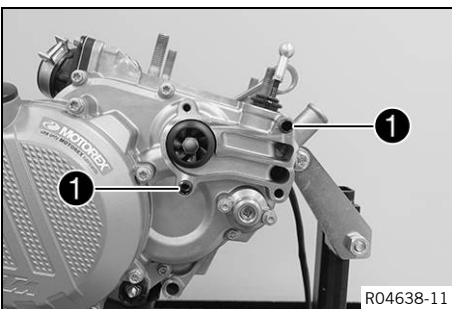

R04638-11

- Mount dowels **1**.

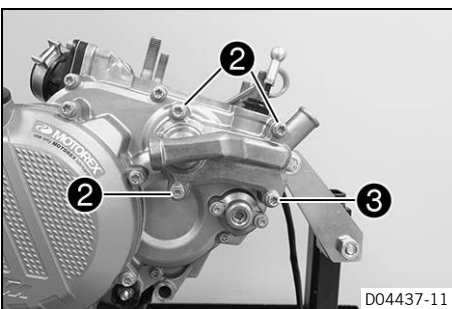

D04437-11

- Mount the molded ring.
- Position the water pump cover.
- Mount and tighten screws **2**.

Guideline

Screw, water pump cover	M6	10 Nm (7.4 lbf ft)
-------------------------	----	--------------------

- Mount and tighten screw **3** with the seal ring.

Guideline

Screw, water pump cover	M6	10 Nm (7.4 lbf ft)
-------------------------	----	--------------------

18.6.20 Installing the piston

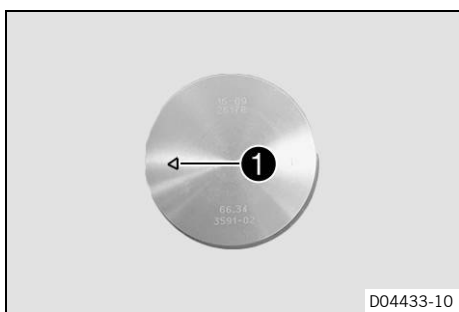

(All 250 models)

- Oil the upper conrod bearing and position it in the connecting rod.
- Position the piston.
 - ✓ Piston marking **1** must face the exhaust side.

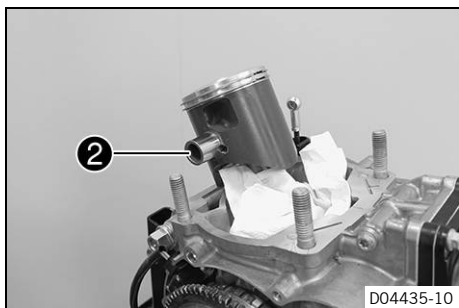

- Cover the engine case opening with a cloth.
- Slide piston pin **2** into the connecting rod by hand.

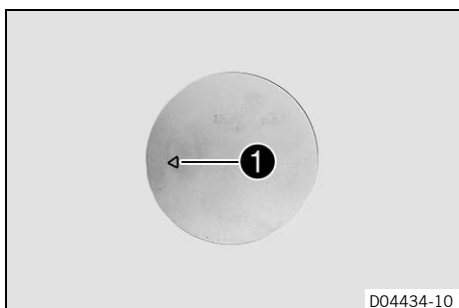

(All 300 models)

- Oil the upper conrod bearing and position it in the connecting rod.
- Position the piston.
 - ✓ Piston marking **1** must face the exhaust side.

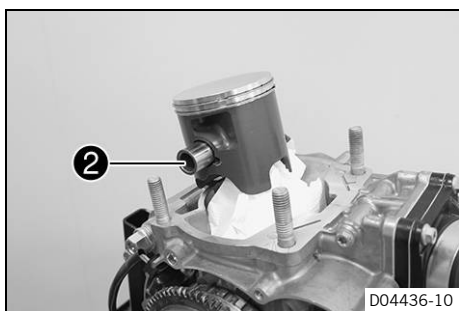

- Cover the engine case opening with a cloth.
- Slide piston pin **2** into the connecting rod by hand.

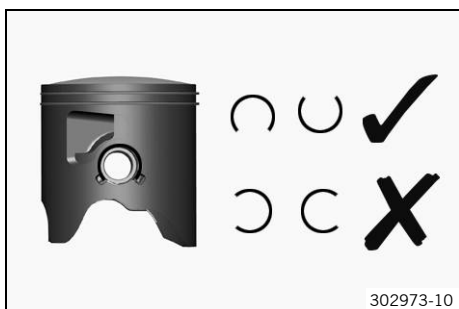

- Position the piston ring locks in the 6 o'clock or 12 o'clock position.
- Ensure that the piston ring lock is in the correct position on both sides.
- Remove the cloth.

18.6.21 Installing the cylinder

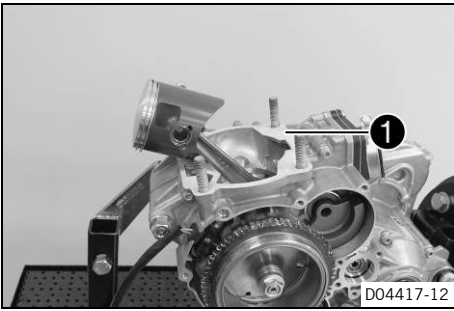

(All 250 models)

- Place the new cylinder base gasket **1** into position.



Info

If neither the piston, cylinder, crankshaft, or engine case need to be changed, the same gasket thickness can be used as before.

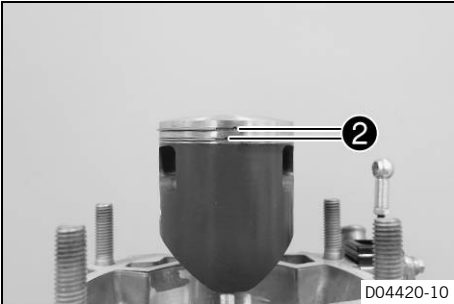

- Oil the cylinder and piston.
- Position the piston ring.
- ✓ The anti-rotation lock engages in piston ring end **2**.



- Slide the cylinder over the piston.
- Push the cylinder down carefully.

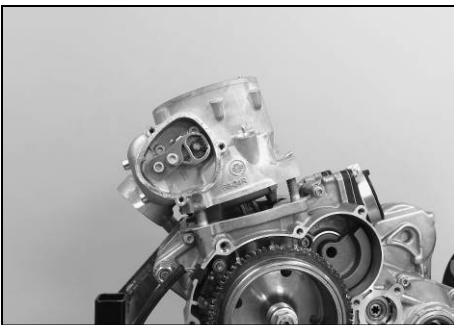

- Mount nuts **3** on both sides and tighten in a crisscross pattern.

Guideline

Nut, cylinder base	M10	35 Nm (25.8 lbf ft)
--------------------	-----	------------------------

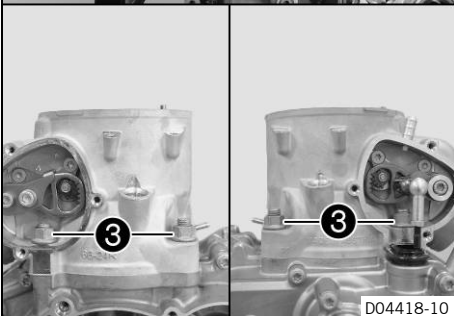

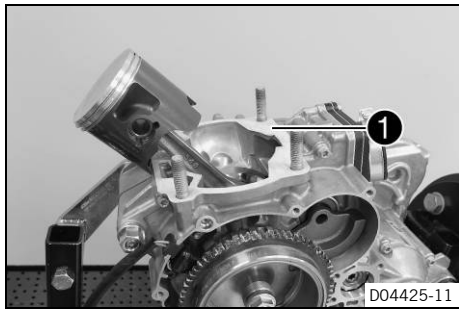

(All 300 models)

- Place new cylinder base gasket **1** in position.



Info

If neither the piston, cylinder, crankshaft, or engine case need to be changed, the same gasket thickness can be used as before.

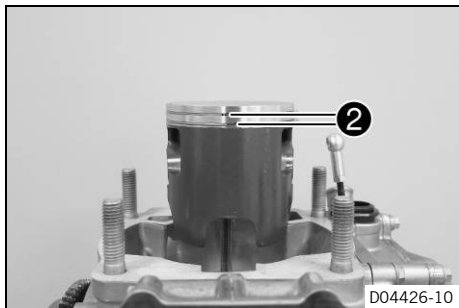

- Oil the cylinder and piston.
- Position the piston ring.
 - ✓ The anti-rotation lock engages in piston ring end **2**.

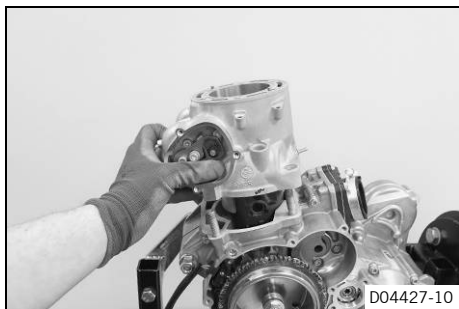

- Slide the cylinder over the piston.
- Push the cylinder down carefully.

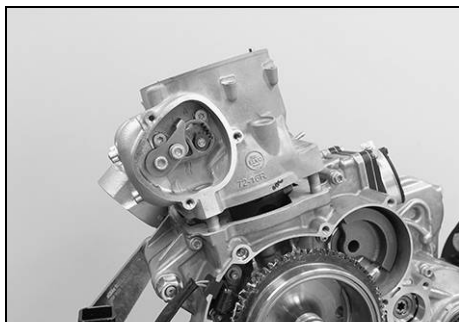

- Mount nuts **3** on both sides and tighten in a crisscross pattern.

Guideline

Nut, cylinder base	M10	35 Nm (25.8 lbf ft)
--------------------	-----	------------------------

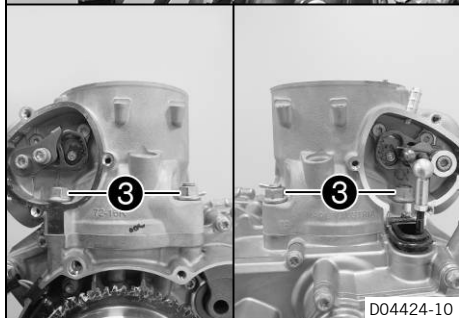

18.6.22 Checking the X-distance

i Info

The X-distance is the distance defined for the piston protrusion, when the cylinder is clamped down and the piston is at top dead center.

The X-distance must be checked very carefully. If the X-distance is too large, the compression decreases and the engine loses power. If the X-distance is too small, the engine knocks and overheats.

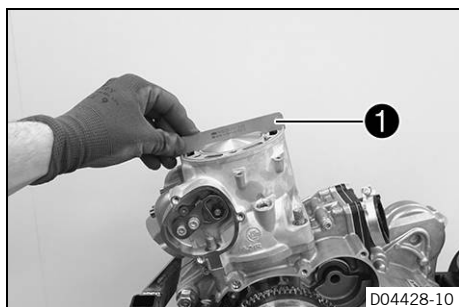

(All 250 models)

- Apply special tool ① to the cylinder.

Setting gauge (54829001100) (📖 p. 365)
--

- Position the piston at top dead center.
- Check the X-distance using the special tool.

Feeler gauge (59029041100) (📖 p. 369)

X distance (upper edge of piston to upper edge of cylinder)	0 ... 0.10 mm (0 ... 0.0039 in)
---	---------------------------------

- » If the specified value is not reached:
 - Adjust the X-distance. (📖 p. 267)

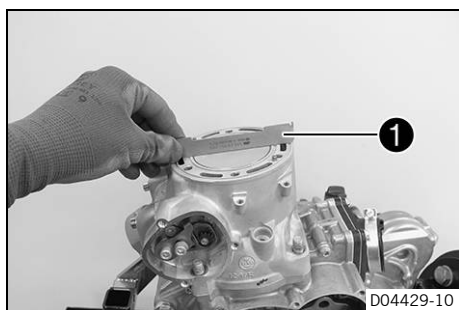

(All 300 models)

- Apply special tool ① to the cylinder.

Setting gauge (54829001100) (📖 p. 365)
--

- Position the piston at top dead center.
- Check the X-distance using the special tool.

Feeler gauge (59029041100) (📖 p. 369)

X distance (upper edge of piston to upper edge of cylinder)	0 ... 0.10 mm (0 ... 0.0039 in)
---	---------------------------------

- » If the specified value is not reached:
 - Adjust the X-distance. (📖 p. 267)



18.6.23 Adjusting the X-distance

i Info

The X-distance is adjusted by inserting cylinder base gaskets of various thicknesses.

Preparatory work

- Check the X-distance. (📖 p. 267)

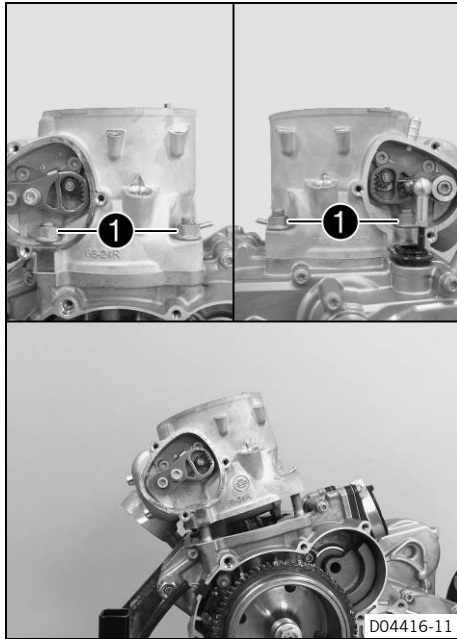

Main work
(All 250 models)

- Remove nuts ①.
- Carefully slide the cylinder up and take it off.

- Replace cylinder base gasket ② with a cylinder base gasket of the required X-distance.

i Info
Multiple cylinder base gaskets can be combined.

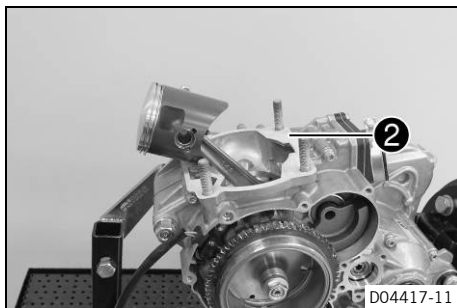

(All 300 models)

- Remove nuts ①.
- Carefully slide the cylinder up and take it off.

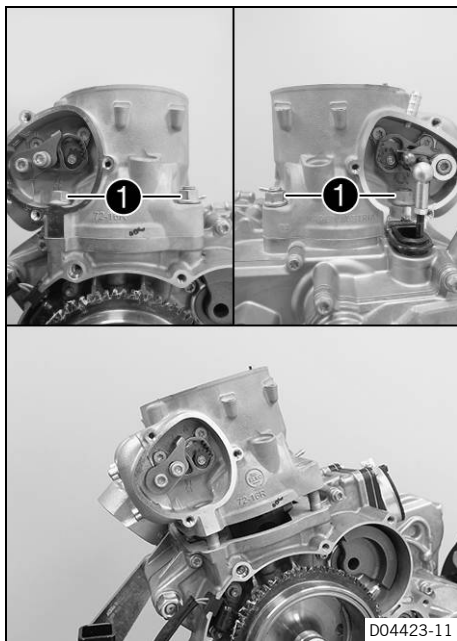

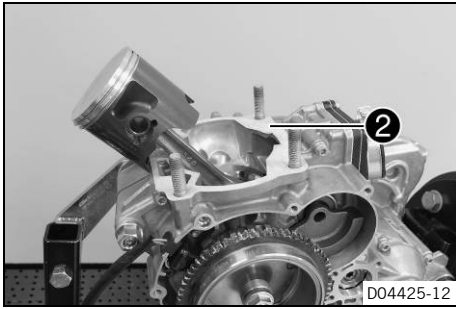

- Replace cylinder base gasket **2** with a cylinder base gasket of the required X-distance.

i Info
Multiple cylinder base gaskets can be combined.

Finishing work

- Install the cylinder. (📖 p. 265)



18.6.24 Adjusting the Z-distance

i Info
The Z-distance is the distance from the lower edge of the control flap to the upper edge of the cylinder, measured in the middle of the exhaust port.

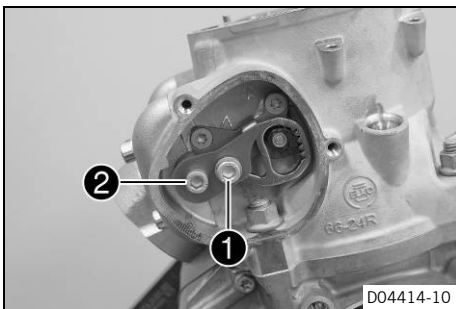

- Remove screws **1** and **2**.
- Remove screws **1** and **2** but do not tighten yet.

Guideline

Screw, control flap, exhaust control	M6	10 Nm (7.4 lbf ft) Loctite®243™
--------------------------------------	----	---

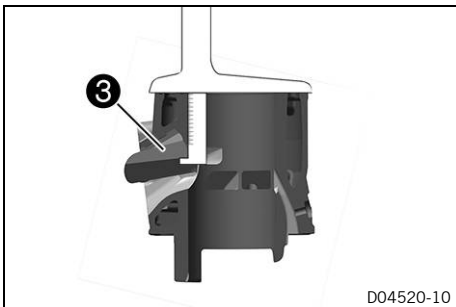

- Adjust the Z dimension using the depth gauge.

Guideline

Z distance (height of control flap) (All 250 models)	49.0 mm (1.929 in)
Z distance (height of control flap) (All 300 models)	49.5 mm (1.949 in)

- Move control flap **3** up and position the depth gauge.

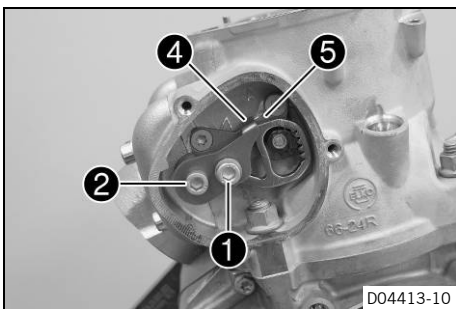

- Position stop plate **4** so it is in contact with retaining bracket **5**.

- Tighten screws **1** and **2**.

Guideline

Screw, control flap, exhaust control	M6	10 Nm (7.4 lbf ft) Loctite®243™
--------------------------------------	----	---

- Check the Z dimension.

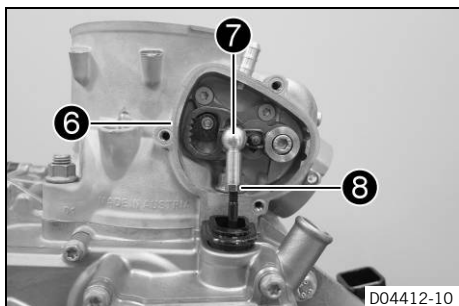

Guideline

Z distance (height of control flap) (All 250 models)	49.0 mm (1.929 in)
Z distance (height of control flap) (All 300 models)	49.5 mm (1.949 in)

- Mount gasket ⑥.
- Push the control flap down all the way to the stop.
- Mount ball socket ⑦.

i Info

The linkage may only be pulled upward slightly. The control flap must not be swung upward.

- Check the movement of the linkage.

Guideline

≤ 1 mm (≤ 0.04 in)

- » If the linkage is pulled up further:
 - Loosen lock nut ③.
 - Turn the ball socket until the linkage reaches the right length.
 - Tighten the lock nut.
- Mount retainer ⑨.

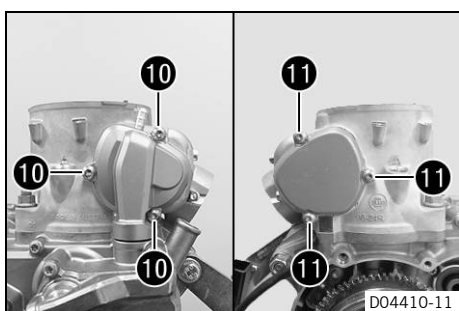
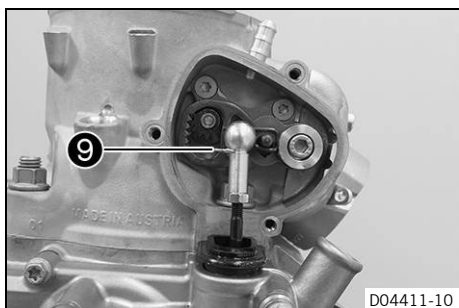

- Position the gasket.
- Position both covers.
- Mount and tighten screws ⑩ and ⑪.

Guideline

Screw, exhaust control cover	M5	4 Nm (3 lbf ft) Loctite® 222™
------------------------------	----	---

18.6.25 Installing the cylinder head

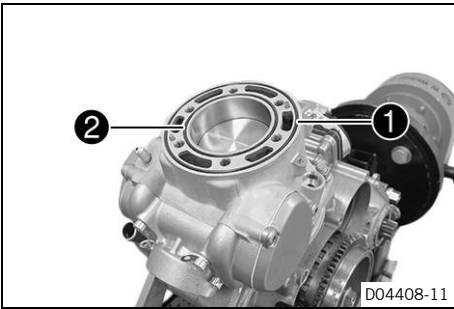

(All 250 models)

- Mount O-rings ① and ②.



Info

Ensure that the pins are seated correctly.

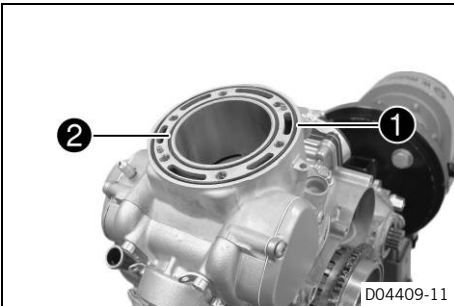

(All 300 models)

- Mount O-rings ① and ②.



Info

Ensure that the pins are seated correctly.

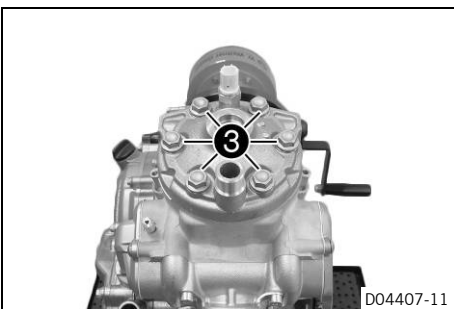

- Put the cylinder head in place.
- Mount screws ③ with the washers and tighten them in a crisscross pattern.

Guideline

Screw, cylinder head	M8	27 Nm (19.9 lbf ft)
----------------------	----	---------------------



Info

Use new washers.

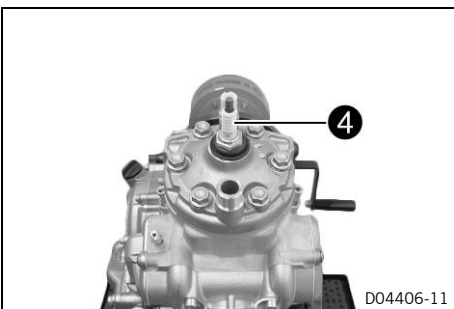

- Mount and tighten spark plug ④.

Guideline

Spark plug	M14x1.25	25 Nm (18.4 lbf ft)
------------	----------	---------------------

18.6.26 Installing injection valves

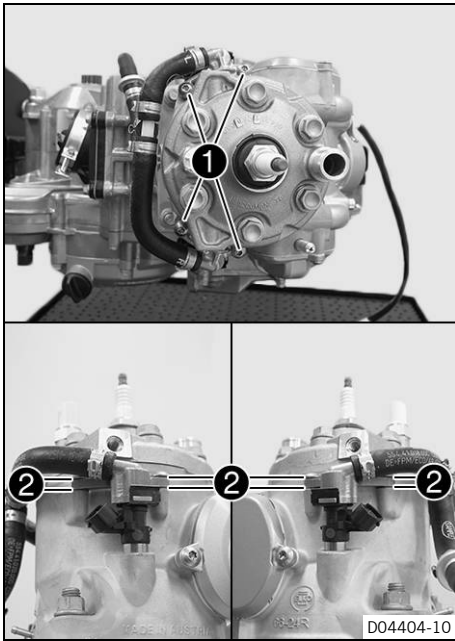

- Position injection valves on both sides.
- Mount and tighten screws **1** with insulating washers **2**.

Guideline

Screw, injection valve holder	M5	5 Nm (3.7 lbf ft) Loctite®243™
-------------------------------	----	--

18.6.27 Installing the kick starter

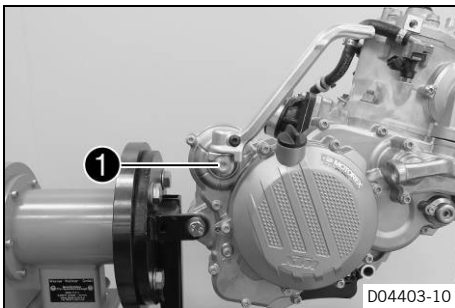

- Position the kick starter.
- Mount and tighten screw **1** with the washer.

Guideline

Screw, kick starter	M8	25 Nm (18.4 lbf ft) Loctite®2701™
---------------------	----	---

18.6.28 Installing the alternator cover

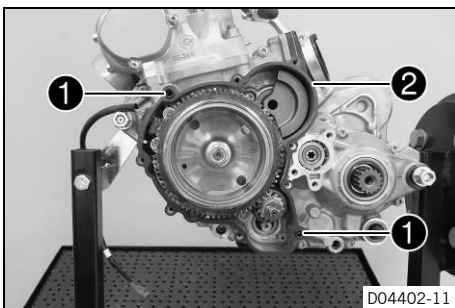

- Mount dowels **1** and put alternator cover gasket **2** in place.

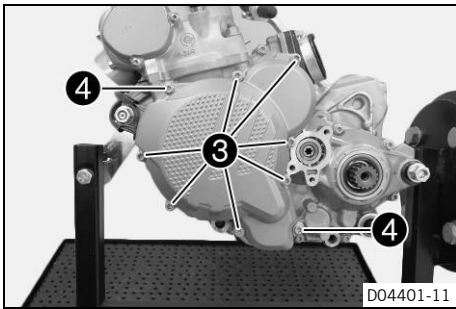

- Position the alternator cover.
- Mount and tighten screws ③.

Guideline

Screw, alternator cover	M6x20	8 Nm (5.9 lbf ft)
-------------------------	-------	-------------------

- Mount and tighten screws ④.

Guideline

Screw, alternator cover	M6x25	8 Nm (5.9 lbf ft)
-------------------------	-------	-------------------

18.6.29 Installing the spacer

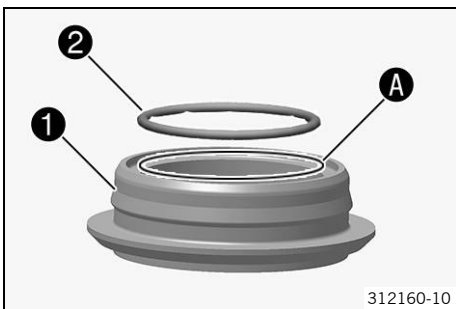

- Before mounting, grease spacer ① in area A and O-ring ②.

Long-life grease (🗨️ p. 360)

- Position the O-ring in the cut-out of the spacer.

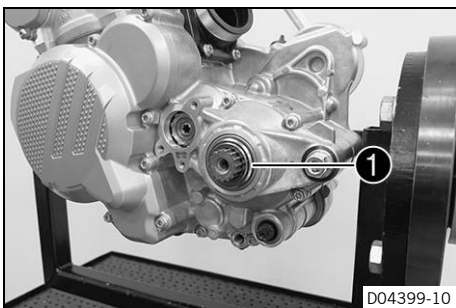

- Grease the shaft seal ring.

Long-life grease (🗨️ p. 360)

- Push spacer ① with the O-ring onto the countershaft with a twisting motion.
 - ✓ The cut-out with the O-ring must face inward.
 - ✓ The shaft seal ring rests against the spacer along its entire circumference.

18.6.30 Installing the gear oil drain plug

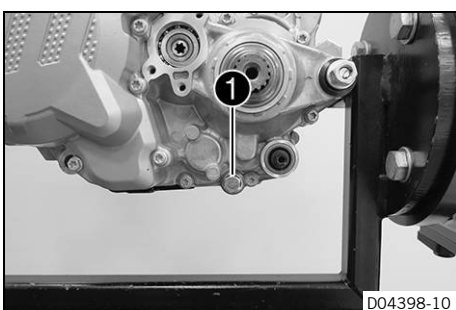

- Mount and tighten gear oil drain plug ① with the magnet and the new seal ring.

Guideline

Gear oil drain plug with magnet	M12x1.5	20 Nm (14.8 lbf ft)
---------------------------------	---------	---------------------

18.6.31 Installing the clutch push rod

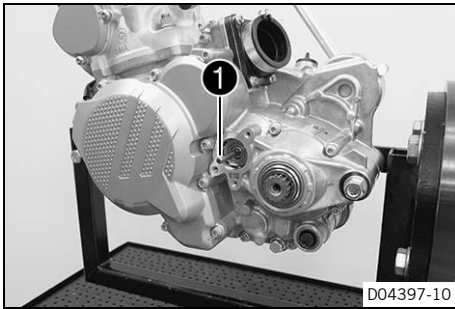

- Mount clutch push rod ①.

18.6.32 Installing the shift lever

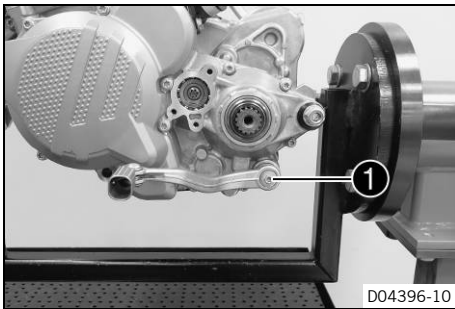

- Position the shift lever. Mount and tighten screw ① with the washers.

Guideline

Screw, shift lever	M6	14 Nm (10.3 lbf ft) Loctite®243™
--------------------	----	--

18.6.33 Removing the engine from the engine work stand

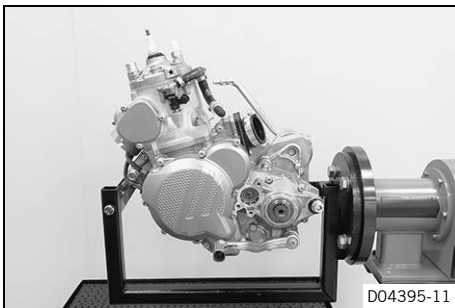

- Remove the fitting from the special tool.

Holder and fitting for work stand (55429002000) (📖 p. 365)

- Remove the engine from the engine work stand.

19.1 Checking/correcting the fluid level of the hydraulic clutch



Warning

Skin irritation Brake fluid causes skin irritation.

- Keep brake fluid out of the reach of children.
- Wear suitable protective clothing and safety glasses.
- Do not allow brake fluid to come into contact with the skin, the eyes or clothing.
- Consult a doctor immediately if brake fluid has been swallowed.
- Rinse the affected area with plenty of water in the event of contact with the skin.
- Rinse eyes thoroughly with water immediately and consult a doctor if brake fluid comes into contact with the eyes.
- If brake fluid spills on to your clothing, change the clothing.



Note

Environmental hazard Hazardous substances cause environmental damage.

- Dispose of oils, grease, filters, fuel, cleaning agents, brake fluid, etc., correctly and in compliance with the applicable regulations.



Info

The fluid level rises with increasing wear of the clutch facing discs.

Never use DOT 5 brake fluid. It is silicone-based and purple in color. Oil seals and clutch lines are not designed for DOT 5 brake fluid.

Avoid contact between brake fluid and painted parts. Brake fluid attacks paint.

Only use clean brake fluid from a sealed container.

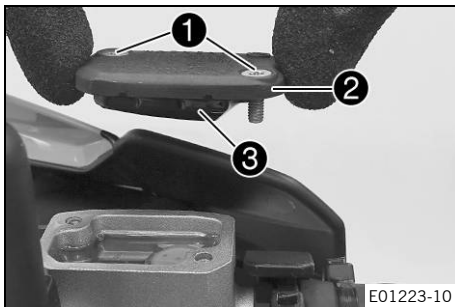

- Move the clutch fluid reservoir mounted on the handlebar to a horizontal position.
- Remove screws ①.
- Remove cover ② with membrane ③.
- Check the fluid level.

Fluid level below container rim	4 mm (0.16 in)
---------------------------------	----------------

» If the level of the fluid does not meet specifications:

- Correct the fluid level of the hydraulic clutch.

Brake fluid DOT 4 / DOT 5.1 (📖 p. 358)
--

- Position the cover with the membrane. Mount and tighten the screws.



Info

Clean up overflowed or spilled brake fluid immediately with water.

19.2 Changing the hydraulic clutch fluid



Warning

Skin irritation Brake fluid causes skin irritation.

- Keep brake fluid out of the reach of children.
- Wear suitable protective clothing and safety glasses.
- Do not allow brake fluid to come into contact with the skin, the eyes or clothing.
- Consult a doctor immediately if brake fluid has been swallowed.
- Rinse the affected area with plenty of water in the event of contact with the skin.
- Rinse eyes thoroughly with water immediately and consult a doctor if brake fluid comes into contact with the eyes.
- If brake fluid spills on to your clothing, change the clothing.



Note

Environmental hazard Hazardous substances cause environmental damage.

- Dispose of oils, grease, filters, fuel, cleaning agents, brake fluid, etc., correctly and in compliance with the applicable regulations.



Info

Never use DOT 5 brake fluid. It is silicone-based and purple in color. Oil seals and clutch lines are not designed for DOT 5 brake fluid.

Avoid contact between brake fluid and painted parts. Brake fluid attacks paint.

Only use clean brake fluid from a sealed container.

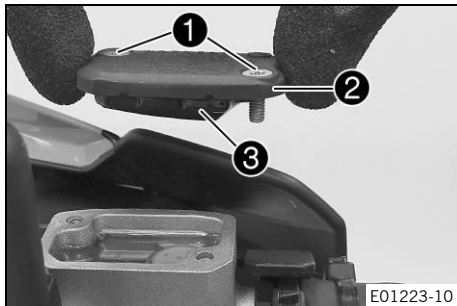

- Move the clutch fluid reservoir mounted on the handlebar to a horizontal position.
- Remove screws ①.
- Take off cover ② with membrane ③.

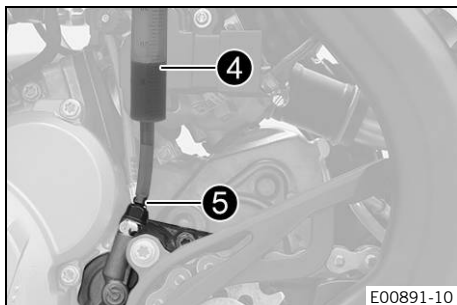

- Fill bleeding syringe ④ with the appropriate hydraulic fluid.
- | |
|--|
| Syringe (50329050000) (📖 p. 364) |
| Brake fluid DOT 4 / DOT 5.1 (📖 p. 358) |
- On the clutch slave cylinder, remove bleeder protection cap, release the bleeder screw ⑤ and mount bleeding syringe ④.

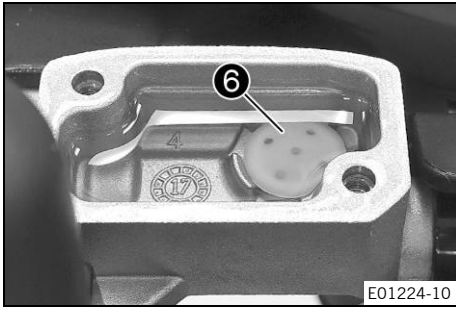

- Now press the fluid into the system until it emerges from the hole 6 of the master cylinder without bubbles.
- Now and then, extract fluid from the master cylinder reservoir to prevent overflow.
- Remove the bleeding syringe. Tighten the bleeder screw. Mount protection cap.
- Correct the fluid level of the hydraulic clutch.

Guideline

Fluid level below container rim	4 mm (0.16 in)
---------------------------------	----------------

- Position cover with membrane. Mount and tighten screws.

i Info
Clean up overflowed or spilled brake fluid immediately with water.

19.3 Checking the clutch



Danger

Fire hazard Fuel is highly flammable.

The fuel in the fuel tank expands when warm and can escape if overfilled.

- Do not refuel the vehicle in the vicinity of open flames or lit cigarettes.
- Switch off the engine for refueling.
- Make sure that no fuel is spilled; particularly not on hot parts of the vehicle.
- If any fuel is spilled, wipe it off immediately.
- Observe the specifications for refueling.



Warning

Danger of poisoning Fuel is poisonous and a health hazard.

- Avoid skin, eye and clothing contact with fuel.
- Immediately consult a doctor if you swallow fuel.
- Do not inhale fuel vapors.
- In case of skin contact, rinse the affected area with plenty of water.
- Rinse the eyes thoroughly with water, and consult a doctor in case of fuel contact with the eyes.
- Change your clothing in case of fuel spills on them.
- Keep fuels correctly in a suitable canister, and out of the reach of children.



Main work

- Drain the fuel from the fuel tank into a suitable container.
- Lay the vehicle on its side on the work stand.

i Info
Cover the components to protect them against damage. Remaining fuel may flow out of the fuel tank.

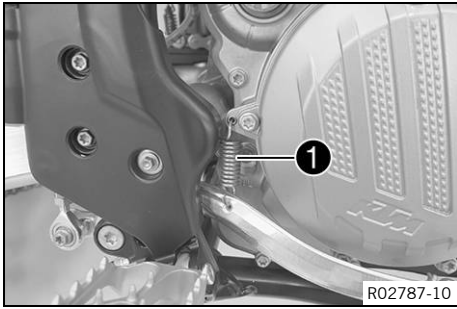

- Detach spring ①.

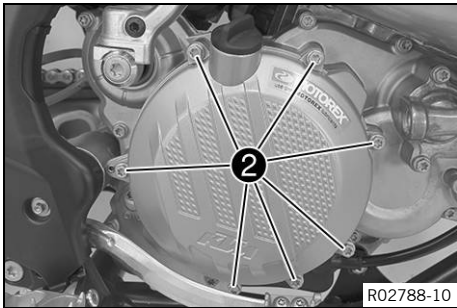

- Remove screws ②.
- Take off the clutch cover with the gasket.

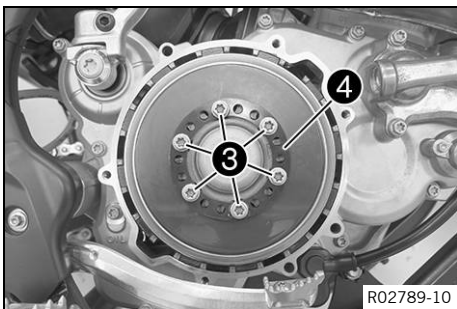

- Loosen screws ③ in a crisscross pattern and remove them.
- Take off spring retainer ④.

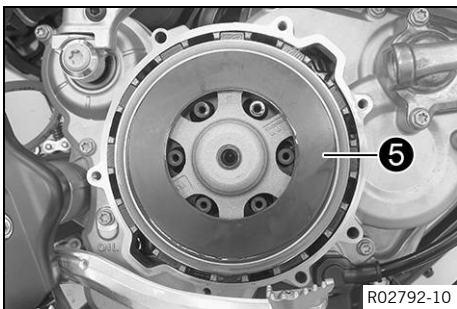

- Take off spring washer ⑤.

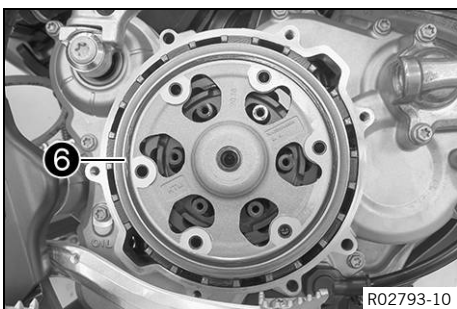

- Take off pretension ring ⑥.

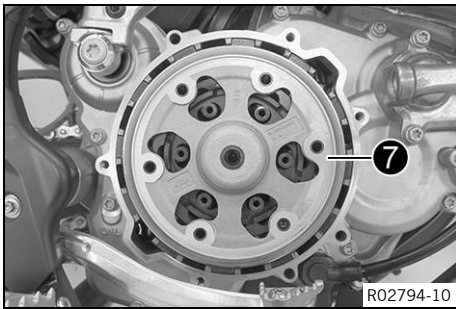

- Take off pressure cap **7**.

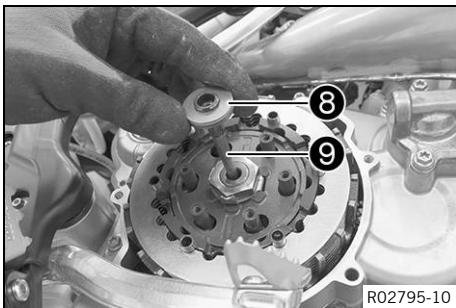

- Take off clutch throw-out **8** with clutch push rod **9**.

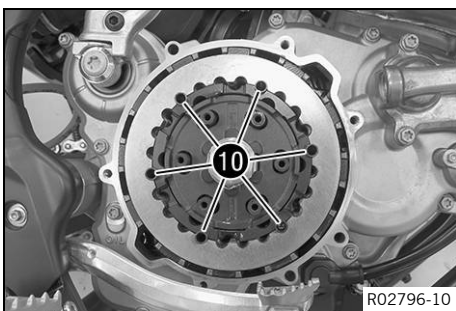

- Remove sleeves **10**.

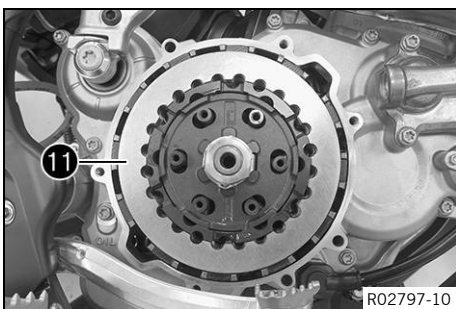

- Remove clutch discs **11** completely.

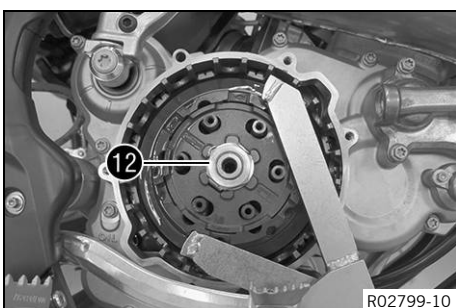

- Bend up the lock washer.
- Hold the inner clutch hub with the special tool. Loosen nut **12**.

Holding wrench (51129003000) (📖 p. 364)

- Remove the nut with the lock washer.

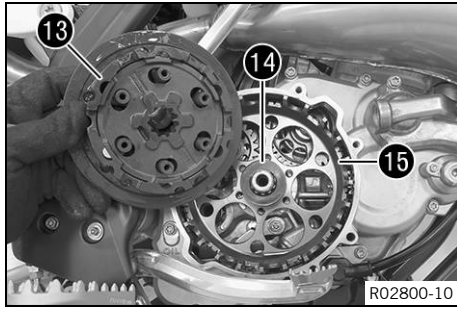

- Take off inner clutch hub **13** and washer **14**.



Info

The washer usually sticks to the inner clutch hub.

- Take off clutch basket **15**.

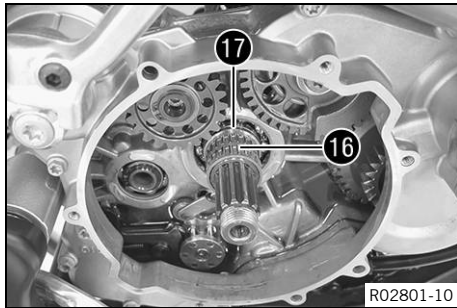

- Take off needle bearing **16** and collar bushing **17**.



Info

The needle bearing and collar sleeve may be in the clutch basket.

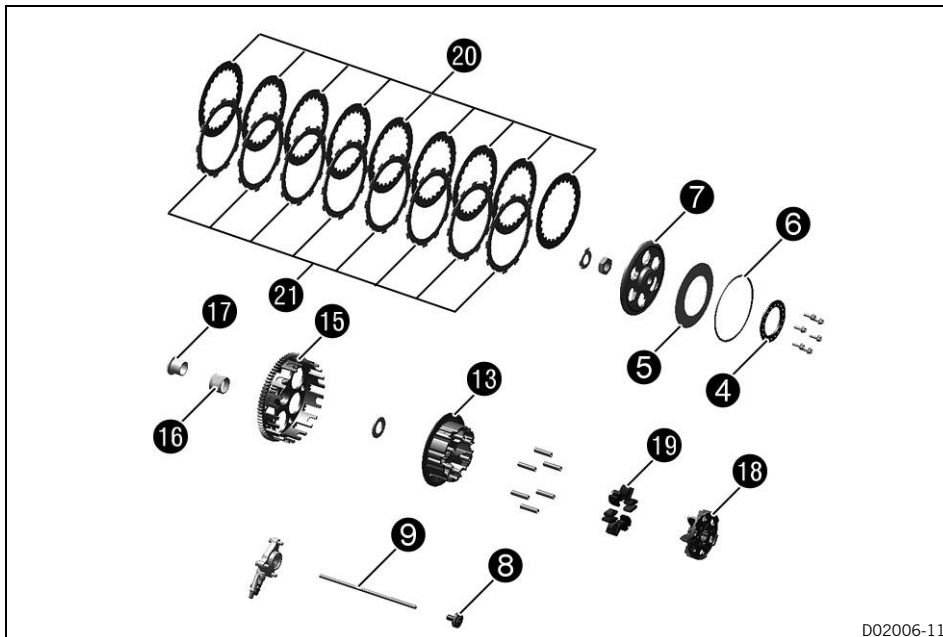

- Check clutch push rod **8** for damage and wear.
 - » If there is damage or wear:
 - Change the clutch push rod.
- Place the clutch push rod **9** on a flat surface and check for run-out.
 - » If there is run-out:
 - Change the clutch push rod.
- Check spring retainer **4** for damage and wear.
 - » If there is damage or wear:
 - Change the spring retainer.
- Check pretension ring **6** for damage and wear.
 - » If there is damage or wear:
 - Change the pretension ring.
- Check spring washer **5** for damage and wear.

- » If there is damage or wear:
 - Change the spring washer.
- Check the contact surface of pressure cap **7** for damage and wear.
 - » If there is damage or wear:
 - Change the pressure cap.
- Check clutch center **18** for damage and wear.
 - » If there is damage or wear:
 - Change the clutch center.
- Check damping rubber pieces **19** for damage and wear.
 - » If there is damage or wear:
 - Change the damping rubber pieces.
- Check inner clutch hub **13** for damage and wear.
 - » If there is damage or wear:
 - Change the inner clutch hub.
- Check the thrust surfaces of the clutch facing discs in clutch basket **15** for damage and wear.
 - » If there is damage or wear:
 - Change the clutch facing discs and the clutch basket.
- Check needle bearing **16** and collar bushing **17** for damage and wear.
 - » If there is damage or wear:
 - Change the needle bearings and collar bushing.
- Check intermediate clutch discs **20** for damage and wear.
 - » If the intermediate clutch discs are not level and are pitted:
 - Change all intermediate clutch discs.
- Check clutch facing discs **21** for discoloration and scoring.
 - » If there is discoloration or scoring:
 - Change all the clutch facing discs.
- Check the thickness of clutch facing discs **21**.

Clutch facing disc - thickness	$\geq 1.9 \text{ mm } (\geq 0.075 \text{ in})$
--------------------------------	--

- » If the clutch facing disc does not meet the specifications:
 - Change all the clutch facing discs.

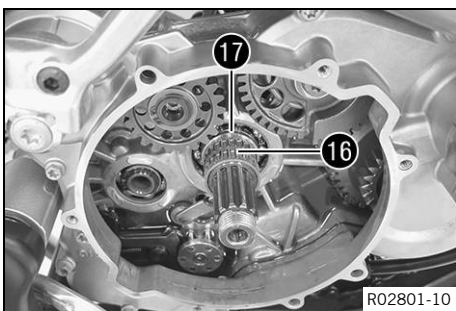

- Mount collar bushing **17** and needle bearing **16**.

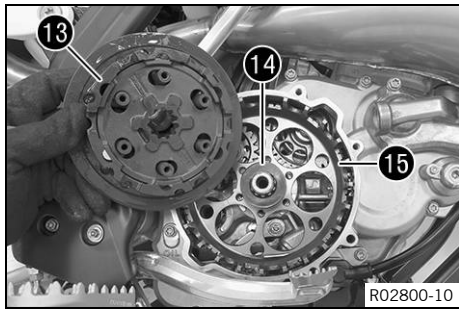

- Mount clutch basket **15**.
- ✓ Turn the clutch basket until the gear teeth of the intermediate kick starter gear mesh.
- Mount washer **14** and inner clutch hub **13**.

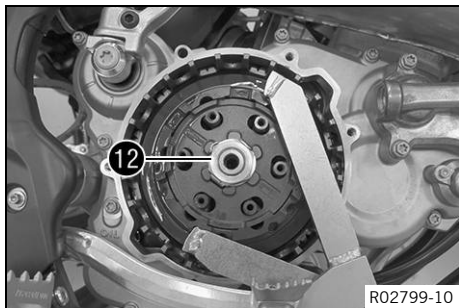

- Position the new lock washer and mount nut **12**. Tighten the nut, holding the inner clutch hub with a special tool.

Guideline

Nut, inner clutch hub	M18x1.5	100 Nm (73.8 lbf ft) Loctite® 648™
-----------------------	---------	--

Holding wrench (51129003000) (📖 p. 364)

- Secure the nut with the lock washer.

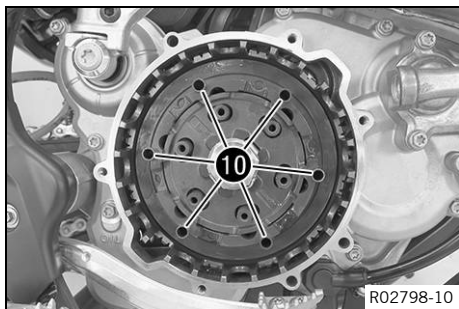

- Mount sleeves **10**.

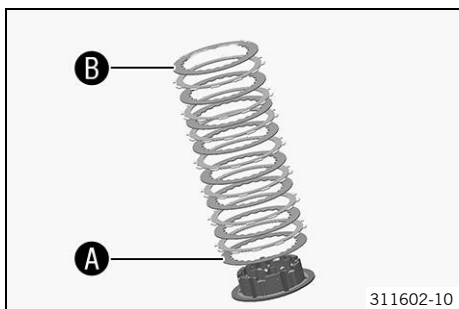

- Oil the clutch facing discs thoroughly.
- Mount intermediate clutch disc **A** with marking **S**.

Guideline

Thickness of intermediate clutch disc A	1.0 mm (0.039 in)
--	-------------------

- Alternately place the clutch facing and 7 intermediate discs into the clutch basket.

Guideline

Thickness of intermediate clutch discs	1.4 mm (0.055 in)
--	-------------------

- Place intermediate clutch disc **B** into the clutch basket.

Guideline

Thickness of intermediate clutch disc B	1.0 mm (0.039 in)
--	-------------------

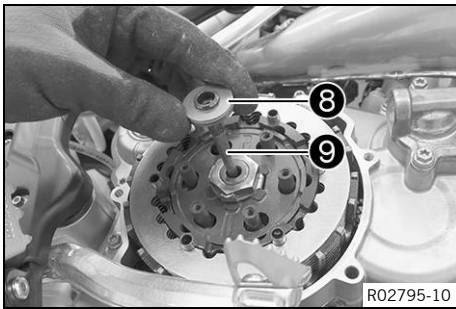

- Mount clutch throw-out **8** with clutch push rod **9**.

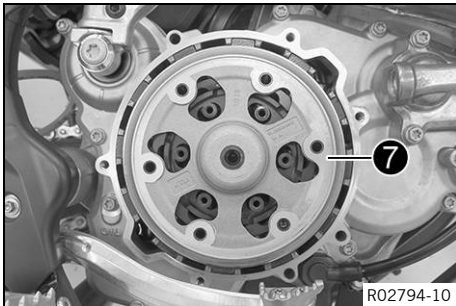

- Position pressure cap **7**.

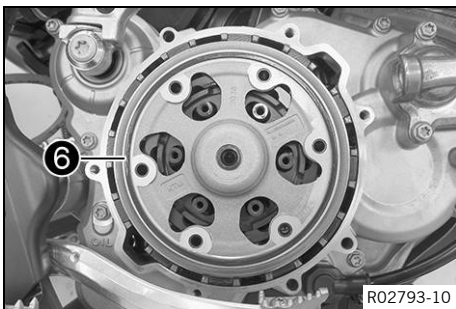

- Mount pretension ring **6** with marking **Top** facing up.

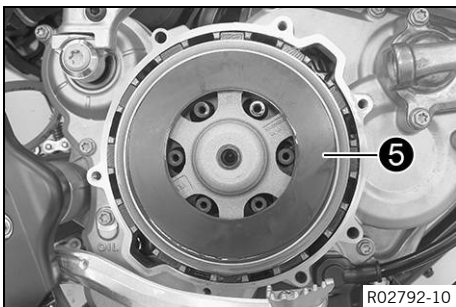

- Position spring washer **5**.

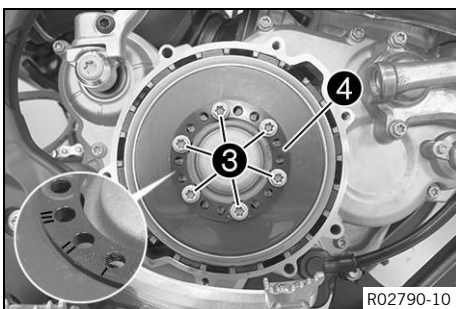

- Position spring retainer **4** with marking **I**.
- Mount screws **3** and tighten in a crisscross pattern.

Guideline

Screw, clutch spring retainer	M5	6 Nm (4.4 lbf ft)
-------------------------------	----	-------------------

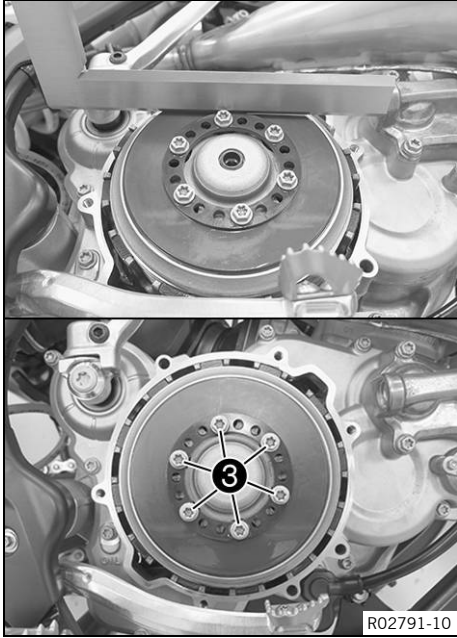

- Using a straightedge and the special tool, check the spring washer for distortion.

Feeler gauge (59029041100) (調 p. 369)	
---------------------------------------	--

Spring washer distortion	0 ... 0.10 mm (0 ... 0.0039 in)
--------------------------	---------------------------------

- » If the specified value is not reached:
 - Remove screws 3 and mount the spring retainer with marking II.

- Using a straightedge and the special tool, check the spring washer for distortion.

Feeler gauge (59029041100) (調 p. 369)	
---------------------------------------	--

Spring washer distortion	0 ... 0.10 mm (0 ... 0.0039 in)
--------------------------	---------------------------------

- » If the specified value is not reached:
 - Remove screws 3 and mount the spring retainer with marking III.

- Using a straightedge and the special tool, check the spring washer for distortion.

Feeler gauge (59029041100) (調 p. 369)	
---------------------------------------	--

Spring washer distortion	0 ... 0.10 mm (0 ... 0.0039 in)
--------------------------	---------------------------------

- » If the specified value is not reached:
 - Change the clutch facing discs.

- Position the clutch cover with the gasket.
- Mount and tighten screws 2.

Guideline

Screw, intermediate clutch cover	M6	10 Nm (7.4 lbf ft)
----------------------------------	----	--------------------

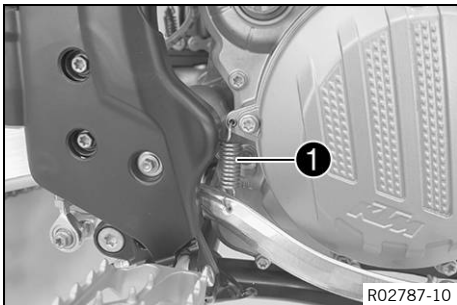
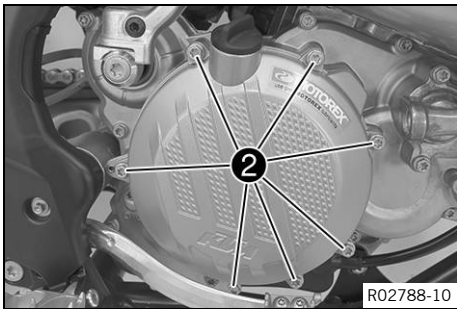

- Attach spring 1.



- Place vehicle in upright position and lean on the side stand.

Finishing work

- Check the gear oil level. (📖 p. 295)



20.1 Cooling system

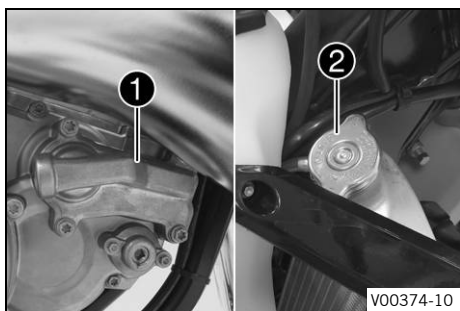

Water pump ① in the engine ensures forced circulation of the coolant.

The pressure resulting from the warming of the cooling system is regulated by a valve in radiator cap ②. This ensures that operating the vehicle at the specified coolant temperature will not result in a risk of malfunctions.

120 °C (248 °F)

Cooling is effected by the air stream.

The lower the speed, the less the cooling effect. Dirty cooling fins also reduce the cooling effect.

20.2 Checking the antifreeze and coolant level



Warning

Danger of scalding During motorcycle operation, the coolant gets very hot and is under pressure.

- Do not open the radiator, the radiator hoses or other cooling system components if the engine or the cooling system are at operating temperature.
- Allow the cooling system and the engine to cool down before you open the radiator, the radiator hoses or other components of the cooling system.
- In the event of scalding, rinse the area affected immediately with lukewarm water.



Warning

Danger of poisoning Coolant is toxic and a health hazard.

- Keep coolant out of the reach of children.
- Do not allow coolant to come into contact with the skin, the eyes and clothing.
- Consult a doctor immediately if coolant is swallowed.
- Rinse the affected area immediately with plenty of water in the event of contact with the skin.
- Rinse eyes thoroughly with water and consult a doctor immediately if coolant gets into the eyes.
- Change clothing if coolant spills onto your clothing.

Condition

The engine is cold.

- Stand the motorcycle upright on a horizontal surface.
- Remove the radiator cap.
- Check the coolant antifreeze.

-25 ... -45 °C (-13 ... -49 °F)

» If the antifreeze in the coolant does not match the specified value:

- Correct the coolant antifreeze.

- Check the coolant level in the radiator.

Coolant level ① above the radiator fins	10 mm (0.39 in)
---	-----------------

» If the coolant level does not match the specified value:

- Correct the coolant level.

Coolant (📖 p. 358)

- Mount the radiator cap.

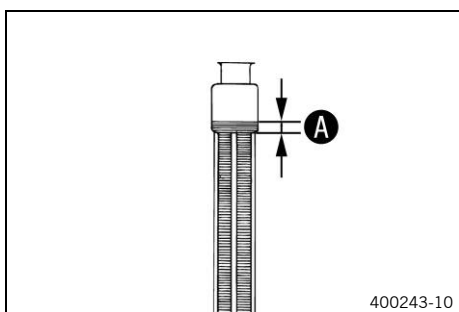

20.3 Checking the coolant level



Warning

Danger of scalding During motorcycle operation, the coolant gets very hot and is under pressure.

- Do not open the radiator, the radiator hoses or other cooling system components if the engine or the cooling system are at operating temperature.
- Allow the cooling system and the engine to cool down before you open the radiator, the radiator hoses or other components of the cooling system.
- In the event of scalding, rinse the area affected immediately with lukewarm water.



Warning

Danger of poisoning Coolant is toxic and a health hazard.

- Keep coolant out of the reach of children.
- Do not allow coolant to come into contact with the skin, the eyes and clothing.
- Consult a doctor immediately if coolant is swallowed.
- Rinse the affected area immediately with plenty of water in the event of contact with the skin.
- Rinse eyes thoroughly with water and consult a doctor immediately if coolant gets into the eyes.
- Change clothing if coolant spills onto your clothing.

Condition

The engine is cold.

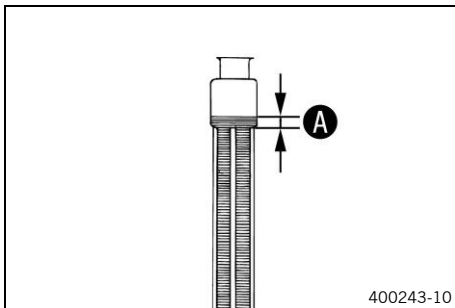

- Stand the motorcycle upright on a horizontal surface.
- Remove the radiator cap.
- Check the coolant level in the radiator.

Coolant level A above the radiator fins	10 mm (0.39 in)
--	-----------------

- » If the coolant level does not match the specified value:
 - Correct the coolant level.

Coolant (📖 p. 358)

- Mount the radiator cap.



20.4 Draining the coolant



Warning

Danger of scalding During motorcycle operation, the coolant gets very hot and is under pressure.

- Do not open the radiator, the radiator hoses or other cooling system components if the engine or the cooling system are at operating temperature.
- Allow the cooling system and the engine to cool down before you open the radiator, the radiator hoses or other components of the cooling system.
- In the event of scalding, rinse the area affected immediately with lukewarm water.



Warning

Danger of poisoning Coolant is toxic and a health hazard.

- Keep coolant out of the reach of children.
- Do not allow coolant to come into contact with the skin, the eyes and clothing.
- Consult a doctor immediately if coolant is swallowed.
- Rinse the affected area immediately with plenty of water in the event of contact with the skin.
- Rinse eyes thoroughly with water and consult a doctor immediately if coolant gets into the eyes.
- Change clothing if coolant spills onto your clothing.

Condition

The engine is cold.

- Position the motorcycle upright.
- Place a suitable container under the water pump cover.
- Remove screw ❶. Take off radiator cap ❷.
- Completely drain the coolant.
- Mount and tighten screw ❶ with a new seal ring.

Guideline

Screw, water pump cover	M6	10 Nm (7.4 lbf ft)
-------------------------	----	--------------------

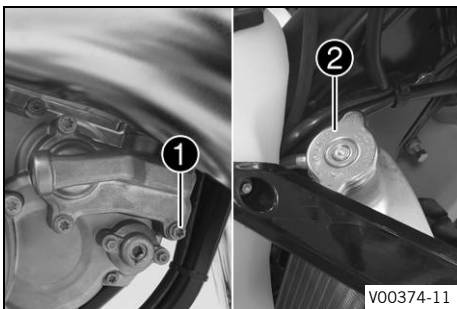

20.5 Refilling with coolant



Warning

Danger of poisoning Coolant is toxic and a health hazard.

- Keep coolant out of the reach of children.
- Do not allow coolant to come into contact with the skin, the eyes and clothing.
- Consult a doctor immediately if coolant is swallowed.
- Rinse the affected area immediately with plenty of water in the event of contact with the skin.
- Rinse eyes thoroughly with water and consult a doctor immediately if coolant gets into the eyes.
- Change clothing if coolant spills onto your clothing.

Main work

- Make sure that screw ❶ is tightened.
- Position the motorcycle upright.

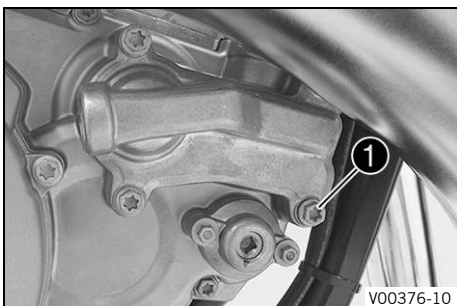

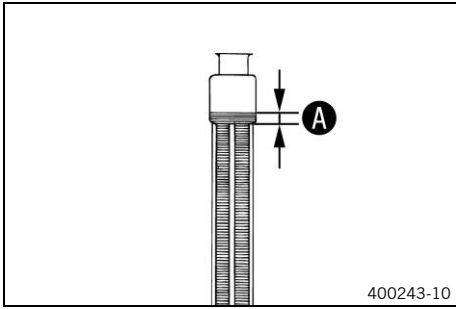

- Pour coolant in up to measurement **A** above the radiator fins.

Guideline

10 mm (0.39 in)		
Coolant	1.2 l (1.3 qt.)	Coolant (📖 p. 358)

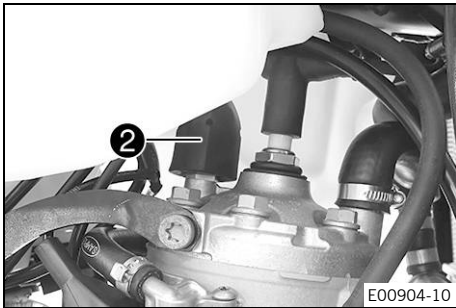

- Push protection cap **2** upward over the thermostat.

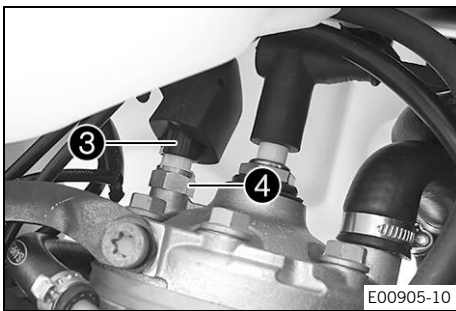

- Unplug connector **3**.
- Remove thermostat **4** with O-ring and wait until the coolant escapes without bubbles.
- Mount thermostat **4** with the O-ring and tighten.

Guideline

Screw, cylinder head temperature sensor	M10x1.25	12 Nm (8.9 lbf ft)
---	----------	--------------------

- Plug in connector **3**.
- Position the protection cap **2**.

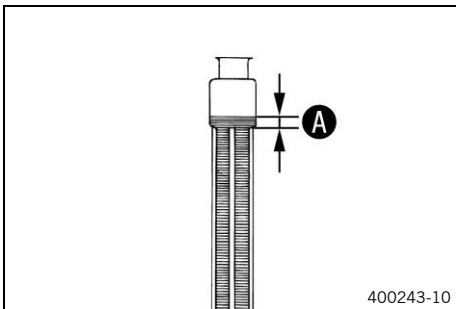

- Pour coolant in up to measurement **A** above the radiator fins.

Guideline

10 mm (0.39 in)		
Coolant (📖 p. 358)		

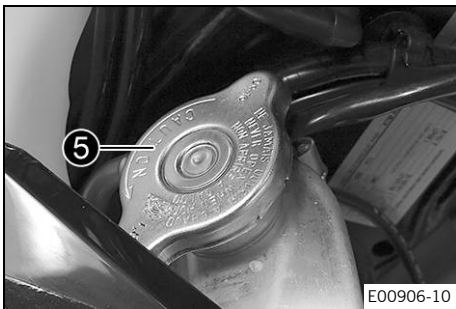

- Mount radiator cap **5**.



Danger

Danger of poisoning Exhaust gases are toxic and inhaling them may result in unconsciousness and death.

- Always make sure there is sufficient ventilation when running the engine.
- Use an effective exhaust extraction system when starting or running the engine in an enclosed space.

- Allow the engine to warm up and cool down again.

Finishing work

- Check the coolant level. (📖 p. 287)



21.1 Checking/adjusting the exhaust control



Danger

Danger of poisoning Exhaust gases are toxic and inhaling them may result in unconsciousness and death.

- Always make sure there is sufficient ventilation when running the engine.
- Use an effective exhaust extraction system when starting or running the engine in an enclosed space.



Warning

Danger of burns Some vehicle components become very hot when the vehicle is operated.

- Do not touch any parts such as the exhaust system, radiator, engine, shock absorber, or brake system before the vehicle parts have cooled down.
- Let the vehicle parts cool down before you perform any work on the vehicle.

Condition

The diagnostics tool is connected and running.

Preparatory work

- Raise the motorcycle with a lift stand. (📖 p. 12)

Main work

- Remove screws ❶.
- Take off the cover with gasket.

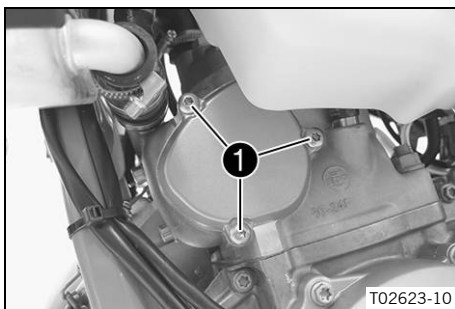

- Position special tool ❷ and mount and tighten screw ❸.

Guideline

Screw, exhaust control cover	M5	4 Nm (3 lbf ft)
------------------------------	----	-----------------

Adjusting gauge (55529022000) (📖 p. 366)

- ✓ Stop is flush with the gear segment.

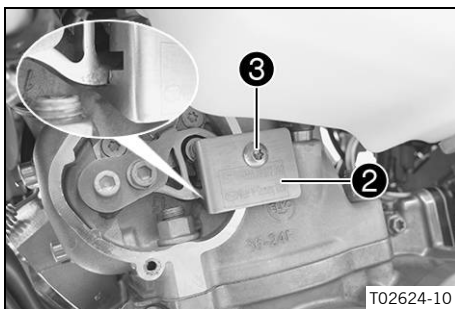

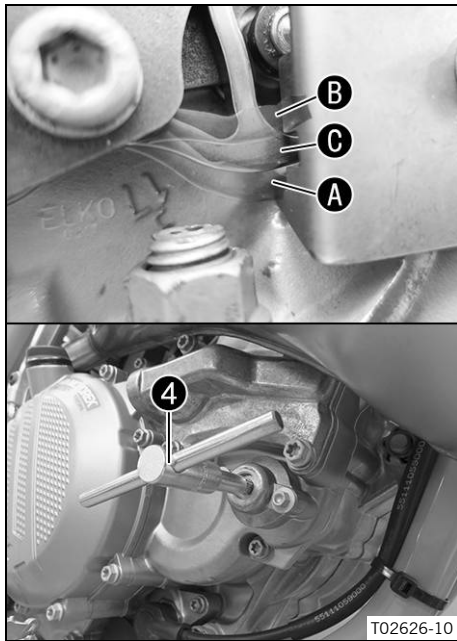

- Execute "**Engine electronics**" > "**Actuator test**" > "**Exhaust control**".
- Start the motorcycle to check the function. (📖 p. 13)



Info

Let the engine warm up.

- Bring the throttle grip into the full load position.
- Check the position of the gear segment with the special tool.

Adjusting gauge (55529022000) (📖 p. 366)

- » If the gear segment is below the recess (position **A**):
 - Loosen the adjusting screw with special tool **4** until it is flush with the locking cap. Screw in the adjusting screw until the gear segment is flush with the recess (position **C**).

Socket wrench (55529021000) (📖 p. 366)



Info

The final adjustment of the adjusting screw must always be clockwise.

- » If the gear segment is above the recess (position **B**):
 - Screw in the adjusting screw until the gear segment is flush with the recess (position **C**).

Socket wrench (55529021000) (📖 p. 366)



Info

The final adjustment of the adjusting screw must always be clockwise.

- » If the gear segment is flush with the recess (position **C**):
 - The exhaust control is set correctly. No adjustment is necessary.

(All EXC models)

- Press and hold the kill switch ☒ while the engine is idling until the engine stops.

(All XC-W models)

- Press and hold the kill switch ☒ while the engine is idling until the engine stops.

- Stop the "**Exhaust control**" actuator test by pressing the "**Quit**" button.

- Remove screw **3** and take off special tool **2**.

Adjusting gauge (55529022000) (📖 p. 366)

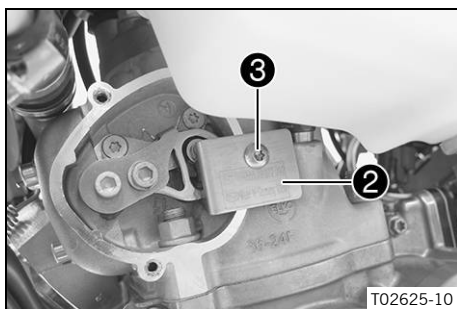

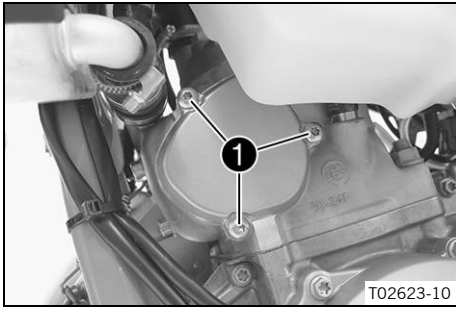

- Position the cover with the gasket.
- Mount and tighten screws ①.

Guideline

Screw, exhaust control cover	M5	4 Nm (3 lbf ft) Loctite® 222™
------------------------------	----	---

Finishing work

- Remove the motorcycle from the lift stand. (📖 p. 12)



22.1 Changing the gear oil



Warning

Danger of scalding Engine and gear oil get very hot when the motorcycle is ridden.

- Wear suitable protective clothing and safety gloves.
- In the event of scalding, rinse the area affected immediately with lukewarm water.



Note

Environmental hazard Hazardous substances cause environmental damage.

- Dispose of oils, grease, filters, fuel, cleaning agents, brake fluid, etc., correctly and in compliance with the applicable regulations.



Info

Drain the gear oil while the engine is at operating temperature.

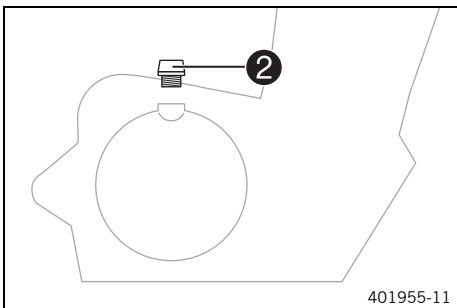
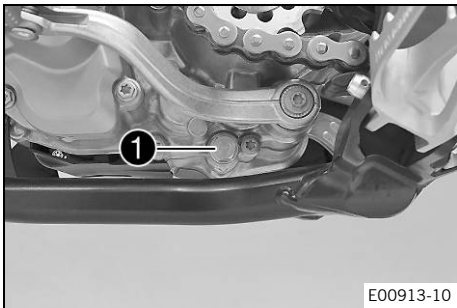

Preparatory work

(All Six Days models)

- Remove the engine guard. (📖 p. 74)
- Park the motorcycle on a level surface.
- Place a suitable container under the engine.

Main work

- Remove gear oil drain plug ① with magnet.
- Let the gear oil drain fully.
- Thoroughly clean the gear oil drain plug with magnet.
- Clean the sealing surface on the engine.
- Mount and tighten gear oil drain plug ① with the magnet and a new seal ring.

Guideline

Gear oil drain plug with magnet	M12x1.5	20 Nm (14.8 lbf ft)
---------------------------------	---------	---------------------

- Remove filler plug ② with the O-ring, and fill up with gear oil.

Gear oil	0.80 l (0.85 qt.)	Engine oil (15W/50) (📖 p. 358)
----------	----------------------	--------------------------------------

- Mount and tighten the filler plug together with the O-ring.



Danger

Danger of poisoning Exhaust gases are toxic and inhaling them may result in unconsciousness and death.

- Always make sure there is sufficient ventilation when running the engine.
- Use an effective exhaust extraction system when starting or running the engine in an enclosed space.

- Start the engine and check for tightness.

Finishing work

- Check the gear oil level. (📖 p. 295)

(All Six Days models)

- Install the engine guard. (📖 p. 74)



22.2 Checking the gear oil level

i Info

The gear oil level must be checked when the engine is cold.

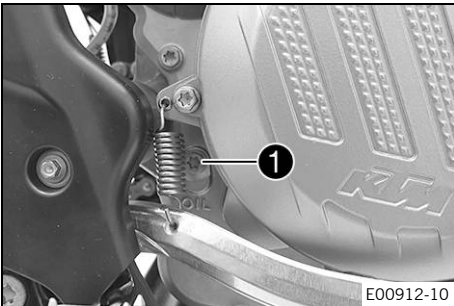

Preparatory work

- Stand the motorcycle upright on a horizontal surface.

Main work

- Detach the foot brake lever spring.
- Remove screw for checking gear oil level **1**.
- Check the gear oil level.

A small quantity of gear oil must run out of the drilled hole.

- » If no gear oil runs out:
 - Add gear oil. (📖 p. 295)
- Mount and tighten the gear oil monitoring screw.

Guideline

Screw, gear oil level check	M6	10 Nm (7.4 lbf ft)
-----------------------------	----	--------------------

- Attach the foot brake lever spring.



22.3 Adding gear oil

i Info

Too little gear oil or poor-quality gear oil results in premature wear to the transmission. Gear oil must only be topped up when the engine is cold.

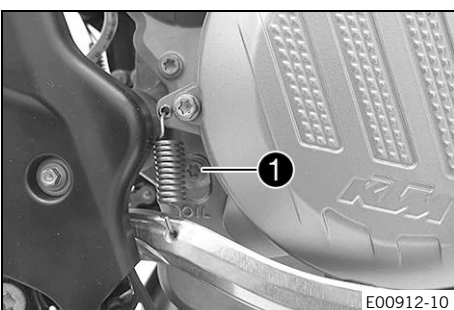

Preparatory work

- Park the motorcycle on a level surface.

Main work

- Detach the foot brake lever spring.
- Remove screw for checking gear oil level **1**.

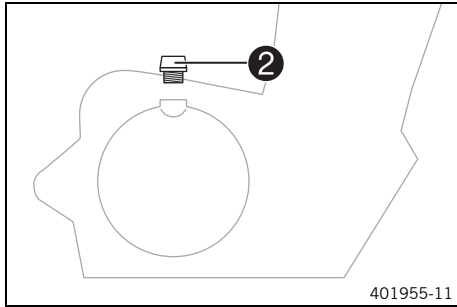

- Remove filler plug ② with the O-ring.
- Add gear oil until it emerges from the drill hole of the gear oil monitoring screw.

Engine oil (15W/50) (📖 p. 358)

- Mount and tighten the gear oil monitoring screw.

Guideline

Screw, gear oil level check	M6	10 Nm (7.4 lbf ft)
-----------------------------	----	--------------------

- Mount and tighten filler plug ② with the O-ring.
- Attach the foot brake lever spring.



Danger

Danger of poisoning Exhaust gases are toxic and inhaling them may result in unconsciousness and death.

- Always make sure there is sufficient ventilation when running the engine.
- Use an effective exhaust extraction system when starting or running the engine in an enclosed space.

- Start the engine and check for tightness.

Finishing work

- Check the gear oil level. (📖 p. 295)

22.4 Checking 2-stroke oil level



Warning

Engine failure The engine will not be lubricated unless there is 2-stroke oil in the oil tank.

If the oil level warning light lights up, the 2-stroke oil is sufficient for the remaining tank of fuel.

- As soon as the oil level warning light lights up, ride for no longer than until the remaining fuel in the tank is depleted.
- At the next opportunity add 2-stroke oil before you refuel.
- Time the oil pump if the 2-stroke oil hose has been removed or the 2-stroke oil tank has been fully depleted in error.

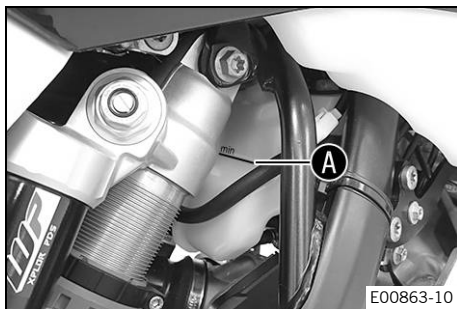

Preparatory work

- Stand the motorcycle upright on a horizontal surface.

Main work

- Check the 2-stroke oil level in the oil tank.



Info

For one tank of fuel, the 2-stroke oil tank must be filled up to at least the **MIN** marking **A**.

The 2-stroke oil tank must be completely if possible.

- » If the 2-stroke oil level is too low:
 - Add 2-stroke oil. (📖 p. 297)

22.5 Opening 2-stroke oil tank cap

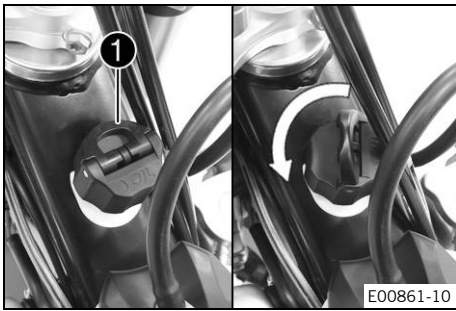

- Fold loop **1** upward.
- Turn the 2-stroke oil tank cap counterclockwise and pull it up.

22.6 Adding 2-stroke oil



Warning

Engine failure The engine will not be lubricated unless there is 2-stroke oil in the oil tank.

If the oil level warning light lights up, the 2-stroke oil is sufficient for the remaining tank of fuel.

- As soon as the oil level warning light lights up, ride for no longer than until the remaining fuel in the tank is depleted.
- At the next opportunity add 2-stroke oil before you refuel.
- Time the oil pump if the 2-stroke oil hose has been removed or the 2-stroke oil tank has been fully depleted in error.

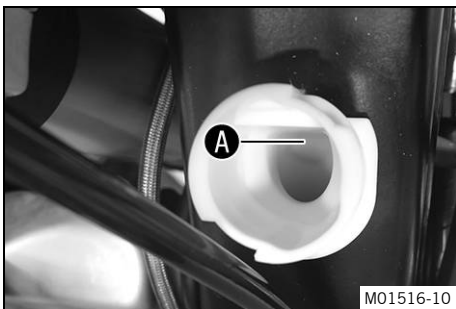

- Open 2-stroke oil tank cap. (📖 p. 297)
- Fill the 2-stroke oil tank up to the lower edge **A** of the filler neck.

2-stroke oil tank content approx.	0.7 l (0.7 qt.)	Engine oil, 2-stroke (📖 p. 358)
-----------------------------------	-----------------	---------------------------------

- Close 2-stroke oil tank cap. (📖 p. 297)

22.7 Closing 2-stroke oil tank cap

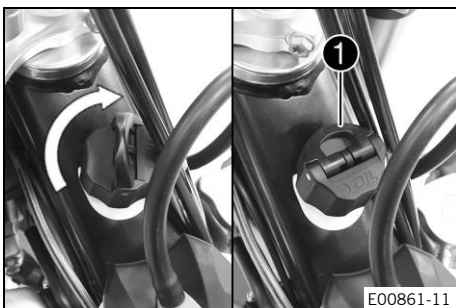

- Put the 2-stroke oil tank cap on and turn it clockwise.
- Fold loop **1** down.
- ✓ The 2-stroke oil tank cap engages.

22.8 Priming the oil pump



Warning

Engine failure The engine will not be lubricated unless there is 2-stroke oil in the oil tank.

If the oil level warning light lights up, the 2-stroke oil is sufficient for the remaining tank of fuel.

- As soon as the oil level warning light lights up, ride for no longer than until the remaining fuel in the tank is depleted.
- At the next opportunity add 2-stroke oil before you refuel.
- Time the oil pump if the 2-stroke oil hose has been removed or the 2-stroke oil tank has been fully depleted in error.

Condition

The engine is off.

Preparatory work

- Remove the seat. (📖 p. 121)
- Stand the motorcycle upright on a horizontal surface.
- Check 2-stroke oil level. (📖 p. 296)

Main work

- Remove protection cap **1** of the diagnostics connector.

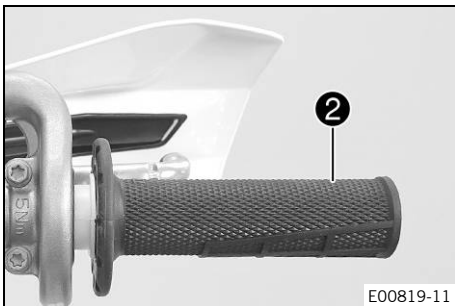
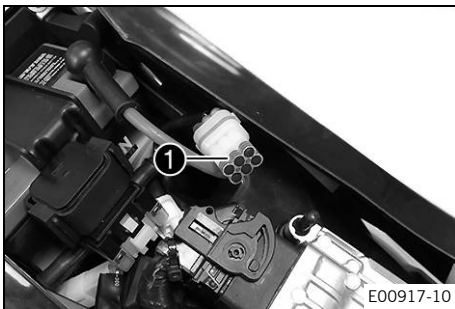

- Put throttle grip **2** into full throttle position and secure.

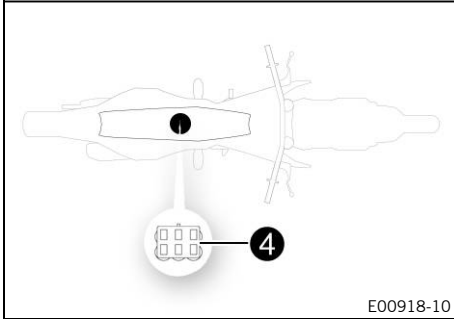
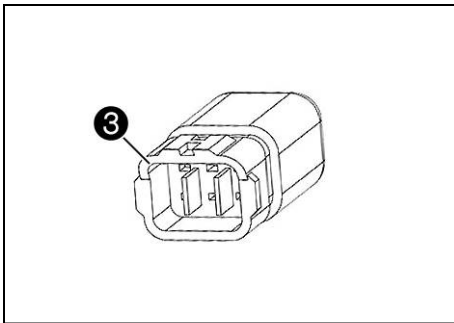

- Plug in wake-up connector ③ for priming the oil pump to the diagnostics connector ④.
- ✓ The combination instrument lighting is activated.

i Info
The connector is included as part of the motorcycle's separate enclosure.

- Wait for at least five seconds.
- Release the fixing means from the throttle grip.
- ✓ The oil pump is timed.

i Info
The oil pump is actuated at various speeds. The procedure is clearly audible.

- Wait until you can no longer hear the oil pump working.
- Disconnect the wake-up connector from the diagnostics connector.

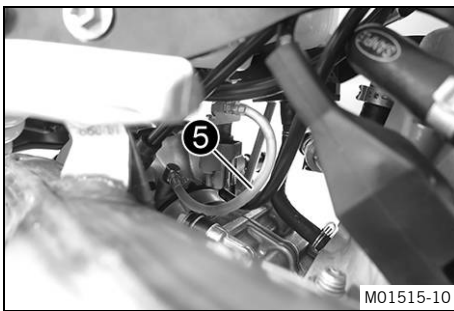

- Check whether air bubbles are visible in the hose ⑤.
 - » If air bubbles are visible:
 - Repeat the entire procedure until air bubbles are no longer visible.
- Mount protection cap on the diagnostics connector.

Finishing work

- Mount the seat. (📖 p. 121)

22.9 Replacing the oil pump

Condition

Oil tank is empty.

Main work

- Unplug connector ①.

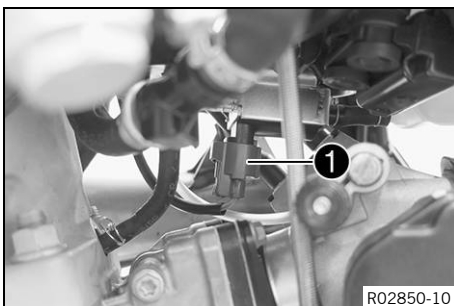

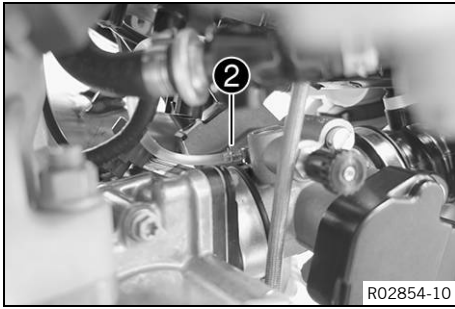

- Push back hose clamp ②.
- Pull off the tube from the throttle valve body.



Info

Residual oil may escape from the tube.

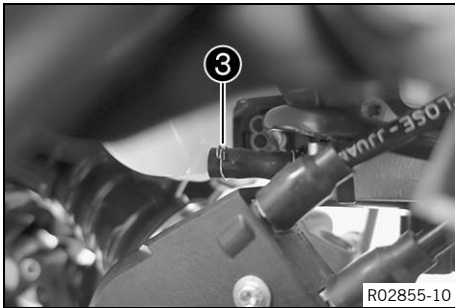

- Push back hose clamp ③.

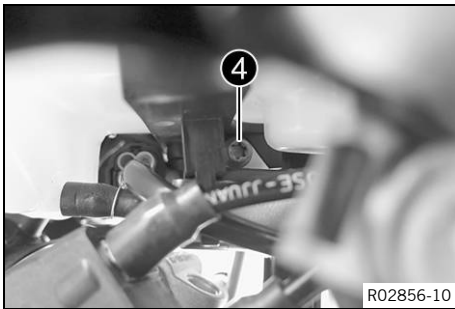

- Remove screw ④.
- Pull off the hose from the oil tank.



Info

Residual oil may escape from the oil tank.

- Remove the oil pump with hoses.
- Position new oil pump with hoses.
- Mount hose on the oil tank.
- Mount and tighten screw ④.

Guideline

Screw, oil pump	M6	7 Nm (5.2 lbf ft)
-----------------	----	-------------------

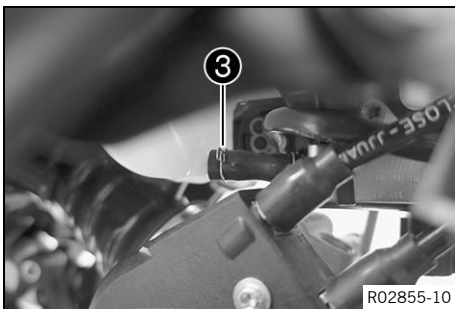

- Position hose clamp ③.

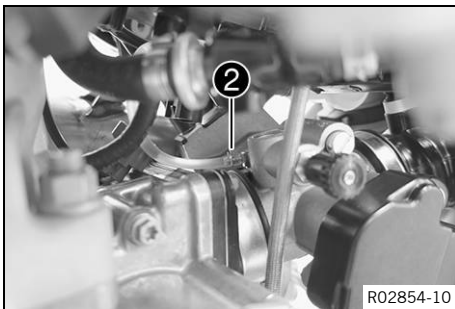

- Mount hose on the throttle valve body.
- Position hose clamp ②.

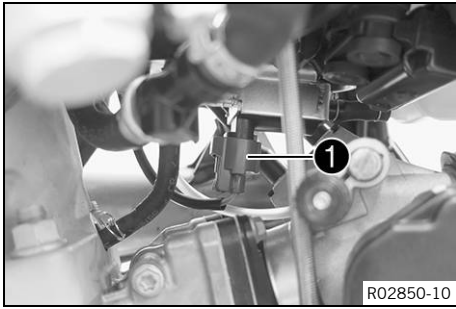

- Plug in connector ①.

Finishing work

- Check 2-stroke oil level. (📖 p. 296)
- Prime the oil pump. (📖 p. 298)
- Mount the seat. (📖 p. 121)



23.1 Checking the ignition system



Warning

Risk of injury The ignition system is under high voltage.

- To avoid the danger of an electric shock, do not touch metal parts and the ends of the connection cable during and immediately after measuring.

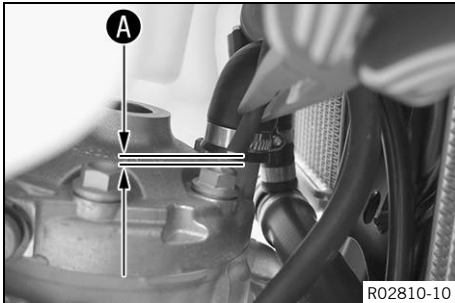

- Shift gear to neutral.
- Unplug the spark plug connector and remove it from the ignition wire.
- Remove the spark plug.
- Hold the free end of the ignition wire at a distance **A** from ground.

Guideline

Distance A	5 mm (0.2 in)
-------------------	---------------

- Press the kick starter robustly through its full range.



Info

Do not open the throttle.

- Check the ignition spark.
 - » If no ignition spark is visible:
 - Check the emergency OFF switch.
 - Check the wiring harness to the emergency OFF switch.
 - Check the kill switch.
 - Check the ground connection of the EFI control unit and ignition coil.
 - Check the cable from the EFI control unit to the ignition coil.



Info

The EFI control unit cannot be tested using simple methods but only using an ignition test bench.

- Ignition coil - check the primary winding. (📖 p. 303)
- Check the crankshaft position sensor. (📖 p. 305)
- Check the stator winding of the alternator. (📖 p. 304)

- Fit spark the plug connector on the ignition wire again. Mount the spark plug in the spark plug connector. Hold the spark plug to ground.
- Press the kick starter robustly through its full range.



Info

Do not open the throttle.

- Check the ignition spark.
 - » If no ignition spark is visible:
 - Check the spark plug connector. (📖 p. 304)
 - Change the spark plug. (📖 p. 306)



23.2 Ignition coil - checking the primary winding



Warning

Risk of injury The ignition system is under high voltage.

- To avoid the danger of an electric shock, do not touch metal parts and the ends of the connection cable during and immediately after measuring.

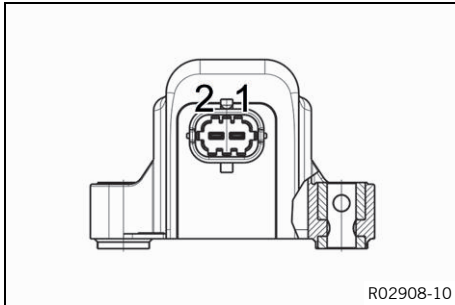

Condition

Ignition coil cylinder 1 is disconnected.

Ignition coil cylinder 1 - check the primary winding resistance.

- Measure the resistance between the specified points.
Ignition coil pin 1 (-) – Ignition coil pin 2 (+)

Ignition coil	
Primary winding resistance at: 20 °C (68 °F)	0.337 ... 0.412 Ω

- » If the displayed value does not correspond to the nominal value:
 - Change the ignition coil.

Condition

Ignition coil cylinder 1 is connected.

- Connect the special tool to the multimeter.

Peak voltage adapter (58429042000) (📖 p. 367)



Info

When using the peak voltage adapter, adjust the measuring range of the multimeter to DCV.

- Start the motorcycle to check the function. (📖 p. 13)

Ignition coil cylinder 1 - check the primary winding voltage.

- Measure the voltage between the specified points.
Ignition coil pin 1 (-) – Ignition coil pin 2 (+)



Info

Connect the black measuring lead to pin 2 and the red measuring lead to pin 1 of the ignition coil.

Ignition coil	
Voltage, primary winding	200 ... 250 V

- » If the displayed value does not correspond to the nominal value:
 - Change the ignition coil.



23.3 Checking the spark plug connector

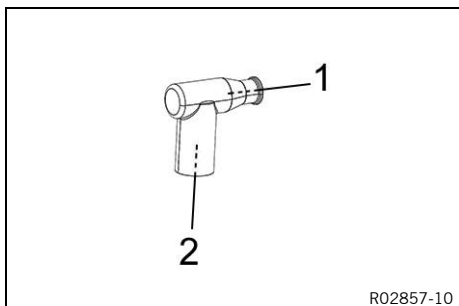

Condition

Spark plug connector cylinder 1 has been removed.

- Ω Measure the resistance between the specified points.
Measuring point 1 – Measuring point 2

Spark plug connector	
Resistance at: 20 °C (68 °F)	4.3 ... 5.7 k Ω

- » If the specification is not reached:
 - Change the spark plug connector.

23.4 Alternator – checking the stator winding

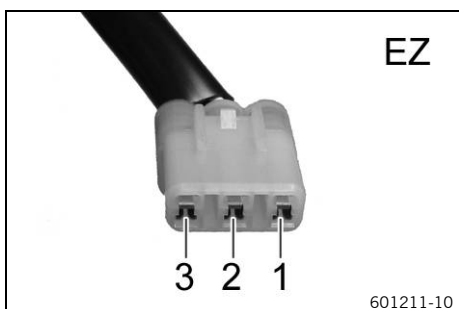

Condition

The stator is disconnected.

Preparatory work

- Remove the seat. (🗨️ p. 121)

Main work

Stator winding measurement I - check the resistance.

- Ω Measure the resistance between the specified points.
Stator, connector **EZ** pin 1 – Stator, connector **EZ** pin 2

Alternator	
Stator winding resistance at: 20 °C (68 °F)	0.368 ... 0.552 Ω

- » If the indicated value does not correspond to the setpoint value:
 - Change the stator.

Stator winding measurement II - check the resistance.

- Ω Measure the resistance between the specified points.
Stator, connector **EZ** pin 1 – Stator, connector **EZ** pin 3

Alternator	
Stator winding resistance at: 20 °C (68 °F)	0.368 ... 0.552 Ω

- » If the indicated value does not correspond to the setpoint value:
 - Change the stator.

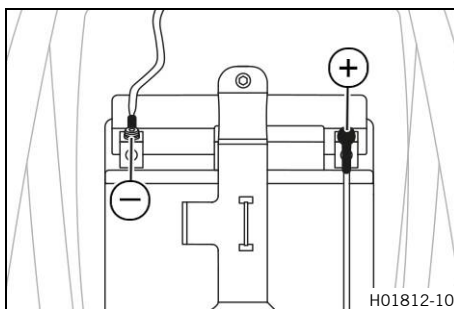
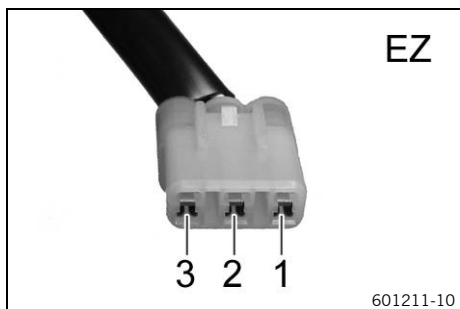

Stator winding - checking the short circuit to ground (terminal 31).

- Measure the resistance between the specified points.
Stator, connector **EZ** pin 1 – Measuring point **Ground (-)**

Resistance	$\infty \Omega$
------------	-----------------

- » If the indicated value does not correspond to the setpoint value:
 - Change the stator.

Finishing work

- Mount the seat. (🔧 p. 121)



23.5 Checking the crankshaft position sensor

Condition

Crankshaft speed sensor is disconnected.

- Measure the resistance between the specified points.
Crankshaft position sensor, connector **AT** pin 1 –
Crankshaft position sensor, connector **AT** pin 2

Crankshaft speed sensor	
Resistance at: 20 °C (68 °F)	80 ... 120 Ω

- » If the specification is not reached:
 - Change the crankshaft position sensor.

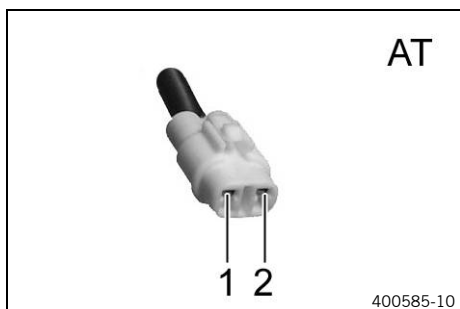
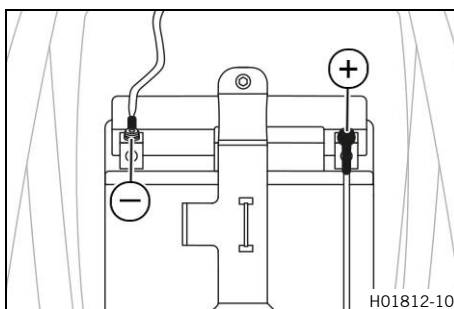
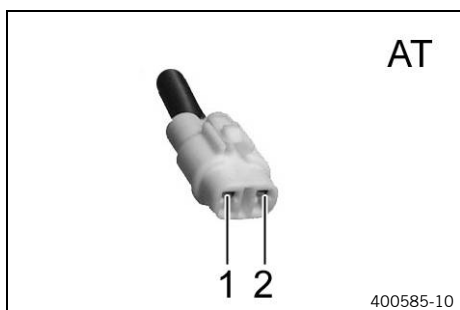

- Measure the resistance between the specified points.
Crankshaft position sensor, connector **AT** pin 1 – Measuring point **Ground (-)**

Resistance	$\infty \Omega$
------------	-----------------

- » If the specification is not reached:
 - Change the crankshaft position sensor.

- Connect the special tool to the multimeter.

Peak voltage adapter (58429042000) (🔧 p. 367)



Info

When using the peak voltage adapter, adjust the measuring range of the multimeter to DCV.

- Start the motorcycle to check the function. (🗨 p. 13)

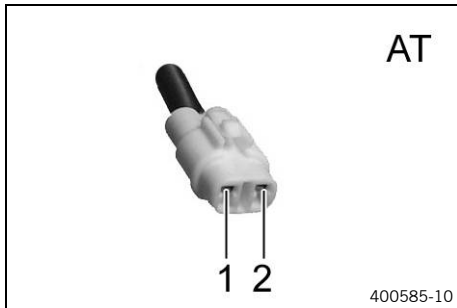

Check the crankshaft position sensor voltage.

- **V** Measure the voltage between the specified points.
 - Crankshaft position sensor, connector **AT** pin 1 –
 - Crankshaft position sensor, connector **AT** pin 2

Crankshaft speed sensor	
Voltage at starting engine speed	2 ... 4 V

- » If the specification is not reached:
 - Change the crankshaft position sensor.

23.6 Changing the spark plug

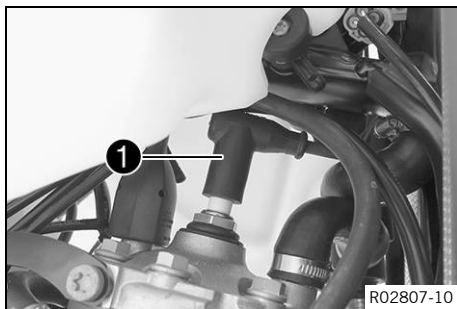

- Disconnect spark plug connector **1**.

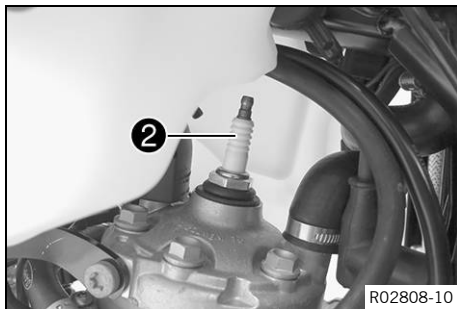

- Remove spark plug **2** using a suitable tool.
 - Mount and tighten the new spark plug using a suitable tool.
- Guideline

Spark plug	M14x1.25	25 Nm (18.4 lbf ft)
------------	----------	---------------------

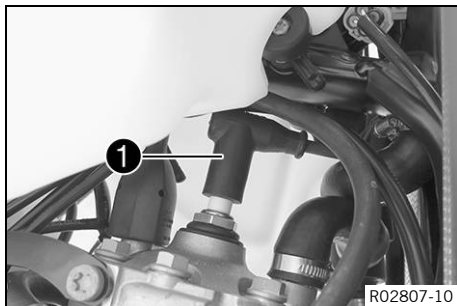

- Plug in spark plug connector **1**.

23.7 Changing the spark plug and spark plug connector

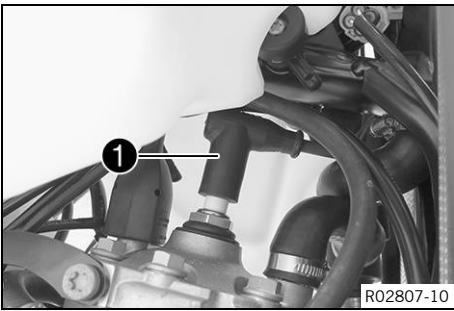

- Disconnect spark plug connector 1.

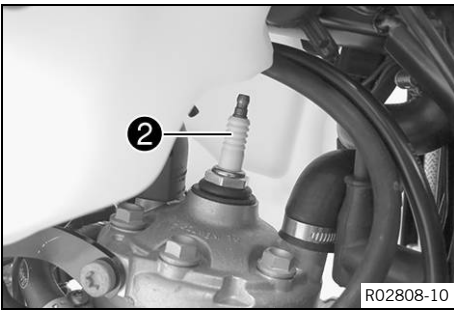

- Remove spark plug 2 using a suitable tool.
- Mount and tighten the new spark plug using a suitable tool.

Guideline

Spark plug	M14x1.25	25 Nm (18.4 lbf ft)
------------	----------	---------------------

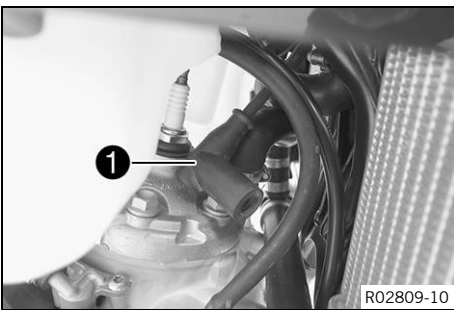

- Remove spark plug connector 1.
- Mount new spark plug connector 1.

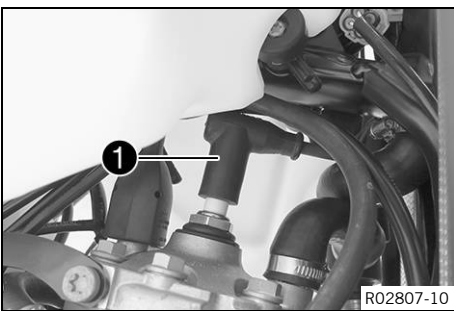

- Plug in spark plug connector 1.

23.8 Removing the stator

Condition

The alternator cover has been removed.

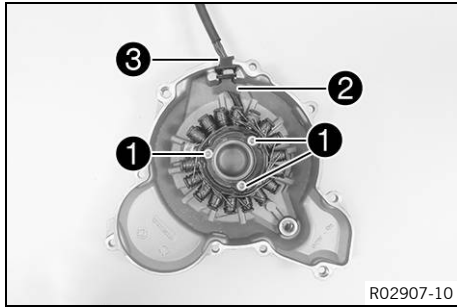

- Remove screws ①.
- Remove retaining bracket ②.
- Remove cable sleeve ③ from the alternator cover.
- Remove the stator from the alternator cover.

23.9 Installing the stator

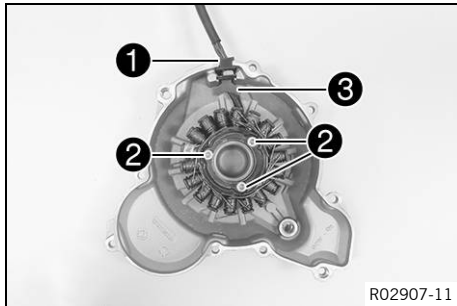

- Position the stator in the alternator cover.
- Position cable sleeve ① in the alternator cover.
- Mount and tighten screws ②.

Guideline

Screw, stator	M5	6 Nm (4.4 lbf ft) Loctite®243™
---------------	----	--

- Mount retaining bracket ③.

24.1 Checking the starter motor

Condition

The starter motor has been removed.

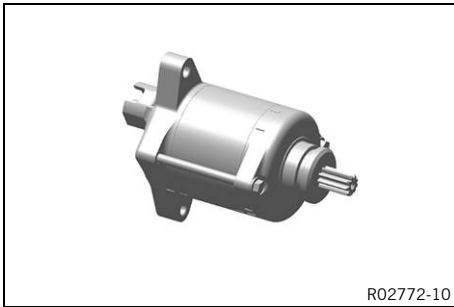

- Clamp the negative cable of a 12 Volt power supply to the housing of the starter motor. Connect the positive cable of the power supply briefly to the connection of the starter motor.
 - » If the starter motor does not turn over when the circuit is closed:
 - Change the starter motor.



25.1 Adjusting the idle speed



Warning

Danger of accidents The engine may go out spontaneously if the idle speed is set too low.

- Set the idle speed to the specified value.

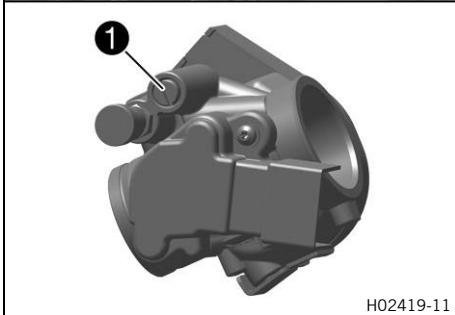
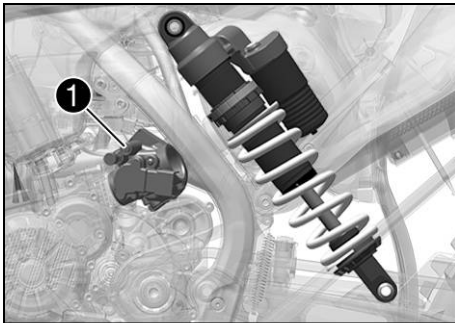

- Run the engine until warm.
- ✓ The cold start button is deactivated – A further ¼ turn returns the cold start button back to the basic position. (📖 p. 311)



Danger

Danger of poisoning Exhaust gases are toxic and inhaling them may result in unconsciousness and death.

- Always make sure there is sufficient ventilation when running the engine.
- Use an effective exhaust extraction system when starting or running the engine in an enclosed space.

- Adjust the idle speed by turning idle speed adjusting screw ①.

Guideline

Idle speed	1,400 ... 1,500 rpm
------------	---------------------

Tachometer (45129075000) (📖 p. 363)



Info

Turn clockwise to decrease the idle speed.
Turn counterclockwise to increase the idle speed.
Make the setting in small steps.
An incorrect idle speed can have a negative impact on overall engine running.

25.2 Programming ambient pressure



Danger

Danger of poisoning Exhaust gases are toxic and inhaling them may result in unconsciousness and death.

- Always make sure there is sufficient ventilation when running the engine.
- Use an effective exhaust extraction system when starting or running the engine in an enclosed space.



Info

If the vehicle is ridden with the engine running at various heights above sea level, the ambient pressure is programmed on an ongoing basis.
If the vehicle is transported over great differences in height, the ambient pressure must be reprogrammed.

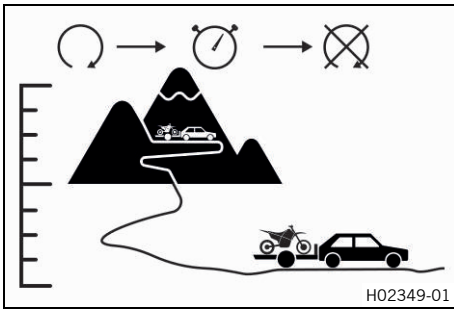

- Start the vehicle at the new height above sea level and switch off the engine again.
- Wait for at least five seconds.
- Start the vehicle again and check the response of the vehicle.
 - » If the response has not improved:
 - Repeat procedure.

25.3 Cold start button

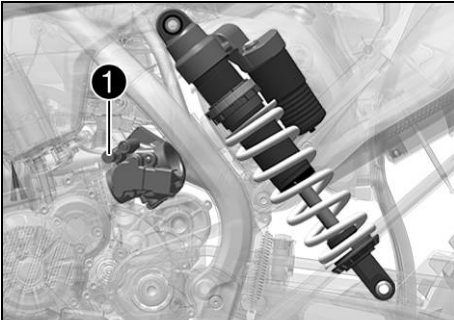

The cold start button **1** is fitted on the side of the throttle valve body.

The injection system extends the injection time if the engine is cold and the outside temperature is low. To help the engine burn the increased amount of fuel, it must be supplied with additional oxygen by pulling the cold start button.

i Info

If the engine is warm, the cold start button must be deactivated.

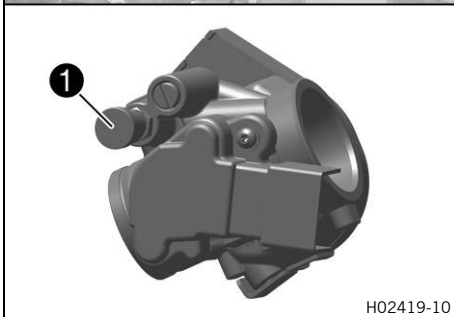

Possible states

- The cold start button is activated – The cold start button is pulled out all the way and turned by a $\frac{1}{4}$ turn.
- The cold start button is deactivated – A further $\frac{1}{4}$ turn returns the cold start button back to the basic position.

26.1 Engine

26.1.1 All 250 models

Design	1-cylinder 2-stroke engine, water-cooled, with reed intake, exhaust control and transfer duct injection
Displacement	249 cm ³ (15.19 cu in)
Stroke	72 mm (2.83 in)
Hole	66.4 mm (2.614 in)
Idle speed	1,400 ... 1,500 rpm
Exhaust valve, beginning of adjustment	5,500 rpm
Crankshaft bearing	1 grooved ball bearing/1 roller bearing
Conrod bearing	Needle bearing
Piston pin bearing	Needle bearing
Piston	Cast aluminum
Piston rings	2 half keystone rings
Engine lubrication	Separate lubrication
X distance (upper edge of piston to upper edge of cylinder)	0 ... 0.10 mm (0 ... 0.0039 in)
Z distance (height of control flap)	49.0 mm (1.929 in)
Primary transmission	26:73
Clutch	Multidisc clutch in oil bath/hydraulically activated
Transmission	6-gear, claw shifted
Transmission ratio	
First gear	14:32
Second gear	16:26
Third gear	20:25
Fourth gear	22:23
Fifth gear	25:22
Sixth gear	26:20
Alternator	12 V, 196 W
Ignition system	Contactless controlled, fully electronic ignition with digital ignition adjustment, type Continental
Spark plug	NGK ZGR 7 G1
Spark plug electrode gap	1.3 mm (0.051 in)
Cooling	Water cooling, permanent circulation of coolant by water pump
Starting aid	Kick starter and electric starter

26.1.2 All 300 models

Design	1-cylinder 2-stroke engine, water-cooled, with reed intake, exhaust control and transfer duct injection
Displacement	293.2 cm ³ (17.892 cu in)
Stroke	72 mm (2.83 in)
Hole	72 mm (2.83 in)
Idle speed	1,400 ... 1,500 rpm
Exhaust valve, beginning of adjustment	5,500 rpm

Crankshaft bearing	1 grooved ball bearing/1 roller bearing
Conrod bearing	Needle bearing
Piston pin bearing	Needle bearing
Piston	Cast aluminum
Piston rings	2 rectangular rings
Engine lubrication	Separate lubrication
X distance (upper edge of piston to upper edge of cylinder)	0 ... 0.10 mm (0 ... 0.0039 in)
Z distance (height of control flap)	49.5 mm (1.949 in)
Primary transmission	26:73
Clutch	Multidisc clutch in oil bath/hydraulically activated
Transmission	6-gear, claw shifted
Transmission ratio	
First gear	14:32
Second gear	16:26
Third gear	20:25
Fourth gear	22:23
Fifth gear	25:22
Sixth gear	26:20
Alternator	12 V, 196 W
Ignition system	Contactless controlled, fully electronic ignition with digital ignition adjustment, type Continental
Spark plug	NGK ZGR 7 G1
Spark plug electrode gap	1.3 mm (0.051 in)
Cooling	Water cooling, permanent circulation of coolant by water pump
Starting aid	Kick starter and electric starter

26.2 Tolerance, engine wear limits

Piston - diameter (All 250 models)	
Size I	66.340 ... 66.350 mm (2.61181 ... 2.6122 in)
Size II	66.351 ... 66.360 mm (2.61224 ... 2.61259 in)
Piston - diameter (All 300 models)	
Size I	71.940 ... 71.950 mm (2.83228 ... 2.83267 in)
Size II	71.951 ... 71.960 mm (2.83271 ... 2.83307 in)
Cylinder - drill hole diameter (All 250 models)	
Size I	66.400 ... 66.412 mm (2.61417 ... 2.61464 in)
Size II	66.412 ... 66.425 mm (2.61464 ... 2.61515 in)
Cylinder - drill hole diameter (All 300 models)	
Size I	72.000 ... 72.012 mm (2.83464 ... 2.83511 in)
Size II	72.012 ... 72.025 mm (2.83511 ... 2.83562 in)
Piston/cylinder - mounting clearance (All 250 models)	
New condition	0.050 ... 0.074 mm (0.00197 ... 0.00291 in)
Wear limit	0.10 mm (0.0039 in)
Piston/cylinder - mounting clearance (All 300 models)	

New condition	0.050 ... 0.085 mm (0.00197 ... 0.00335 in)
Wear limit	0.10 mm (0.0039 in)
Piston ring - end gap	
Ring 1	≤ 0.40 mm (≤ 0.0157 in)
Ring 2	≤ 0.40 mm (≤ 0.0157 in)
Cylinder/cylinder head - distortion of sealing surface	≤ 0.10 mm (≤ 0.0039 in)
Connecting rod - axial play of lower conrod bearing	0.60 ... 0.70 mm (0.0236 ... 0.0276 in)
Crankshaft - run-out at bearing pin	≤ 0.03 mm (≤ 0.0012 in)
Clutch facing disc - thickness	≥ 1.9 mm (≥ 0.075 in)
Thrust surface, clutch facing discs in clutch basket	≤ 0.5 mm (≤ 0.02 in)
Shift shaft - sliding plate/shift quadrant play	0.40 ... 0.80 mm (0.0157 ... 0.0315 in)

26.3 Engine tightening torques

Screw, inner membrane sheets	EJOTDELTA PT® 35x25	1 Nm (0.7 lbf ft)	
Screw, membrane support plate	EJOTDELTA PT® 30x12	1 Nm (0.7 lbf ft)	
Screw, outer membrane sheets	EJOTDELTA PT® 30x6	1 Nm (0.7 lbf ft)	
Screw, angle lever, exhaust control	M5	6 Nm (4.4 lbf ft)	Loctite®243™
Screw, bearing retainer	M5	7 Nm (5.2 lbf ft)	Loctite®243™
Screw, clutch spring retainer	M5	6 Nm (4.4 lbf ft)	
Screw, crankshaft position sensor	M5	6 Nm (4.4 lbf ft)	Loctite®243™
Screw, exhaust control bearing support	M5	6 Nm (4.4 lbf ft)	Loctite®243™
Screw, exhaust control cap	M5	5 Nm (3.7 lbf ft)	
Screw, exhaust control cover	M5	4 Nm (3 lbf ft)	Loctite® 222™
Screw, injection valve holder	M5	5 Nm (3.7 lbf ft)	Loctite®243™
Screw, locking lever	M5	6 Nm (4.4 lbf ft)	Loctite®243™
Screw, retaining bracket of exhaust control	M5	7 Nm (5.2 lbf ft)	Loctite®2701™
Screw, stator	M5	6 Nm (4.4 lbf ft)	Loctite®243™
Cap nut, water pump impeller	M6	6 Nm (4.4 lbf ft)	Loctite®243™
Screw, alternator cover	M6	8 Nm (5.9 lbf ft)	
Screw, clutch slave cylinder	M6	10 Nm (7.4 lbf ft)	
Screw, control flap, exhaust control	M6	10 Nm (7.4 lbf ft)	Loctite®243™
Screw, engine case	M6	10 Nm (7.4 lbf ft)	
Screw, exhaust flange	M6	8 Nm (5.9 lbf ft)	
Screw, gear oil level check	M6	10 Nm (7.4 lbf ft)	
Screw, intake flange/reed valve housing	M6	6 Nm (4.4 lbf ft)	

Screw, intermediate clutch cover	M6	10 Nm (7.4 lbf ft)
Screw, kick starter stop plate	M6	10 Nm (7.4 lbf ft) Loctite®243™
Screw, outer clutch cover	M6	8 Nm (5.9 lbf ft)
Screw, shift drum locating	M6	10 Nm (7.4 lbf ft) Loctite®243™
Screw, shift lever	M6	14 Nm (10.3 lbf ft) Loctite®243™
Screw, starter motor	M6	10 Nm (7.4 lbf ft)
Screw, starter motor bearing bush	M6	10 Nm (7.4 lbf ft) Loctite®243™
Screw, starter motor protection cap	M6	8 Nm (5.9 lbf ft)
Screw, vacuum connections	M6	8 Nm (5.9 lbf ft) Loctite®2701™
Screw, water pump cover	M6	10 Nm (7.4 lbf ft)
Screw, balancer shaft	M8	30 Nm (22.1 lbf ft) Loctite®243™
Screw, cylinder head	M8	27 Nm (19.9 lbf ft)
Screw, kick starter	M8	25 Nm (18.4 lbf ft) Loctite®2701™
Nut, cylinder base	M10	35 Nm (25.8 lbf ft)
Screw, drive chain engine sprocket	M10	60 Nm (44.3 lbf ft) Loctite®2701™
Stud, cylinder base	M10	25 Nm (18.4 lbf ft) Loctite®243™
Screw, cylinder head temperature sensor	M10x1.25	12 Nm (8.9 lbf ft)
Nut, rotor	M12x1	60 Nm (44.3 lbf ft)
Gear oil drain plug with magnet	M12x1.5	20 Nm (14.8 lbf ft)
Spark plug	M14x1.25	25 Nm (18.4 lbf ft)
Nut, inner clutch hub	M18x1.5	100 Nm (73.8 lbf ft) Loctite® 648™
Nut, primary gear	M18LHx1.5	150 Nm (110.6 lbf ft) Loctite® 648™

26.4 Capacities

26.4.1 Gear oil

Gear oil	0.80 l (0.85 qt.)	Engine oil (15W/50) (📖 p. 358)
----------	-------------------	--------------------------------

26.4.2 Engine oil

2-stroke oil tank content approx.	0.7 l (0.7 qt.)	Engine oil, 2-stroke (📖 p. 358)
-----------------------------------	-----------------	---------------------------------

26.4.3 Coolant

Coolant	1.2 l (1.3 qt.)	Coolant (📖 p. 358)
---------	-----------------	--------------------

26.4.4 Fuel

Total fuel tank capacity, approx.	9 l (2.4 US gal)	Super unleaded (ROZ 95/RON 95/PON 91) (📖 p. 359)
Fuel reserve, approx.	1.5 l (1.6 qt.)	

26.5 Chassis

Frame	Central tube frame made of chrome molybdenum steel tubing	
Fork (All standard EXC/XC-W models)	WP SuspensionXplor 48	
Fork (All Six Days models)	WP SuspensionXplor 48 PA	
Suspension travel		
front	300 mm (11.81 in)	
Suspension travel		
rear	310 mm (12.2 in)	
Fork offset	22 mm (0.87 in)	
Shock absorber	WP Suspension 5018 PDS DCC	
Brake system	Disc brakes, brake calipers on floating bearings	
Brake discs - diameter		
front	260 mm (10.24 in)	
rear	220 mm (8.66 in)	
Brake discs - wear limit (All standard EXC/XC-W models)		
front	2.5 mm (0.098 in)	
rear	3.5 mm (0.138 in)	
Brake discs - wear limit (All Six Days models)		
front	2.5 mm (0.098 in)	
rear	3.7 mm (0.146 in)	
Tire air pressure, road (All EXC models)		
front	1.5 bar (22 psi)	
rear	1.5 bar (22 psi)	
Tire air pressure off road		
front	1.0 bar (15 psi)	
rear	1.0 bar (15 psi)	
Secondary ratio	14:50 (13:50)	
Chain	5/8 x 1/4"	
Rear sprockets available	38, 40, 42, 45, 48, 49, 50, 51, 52	
Steering head angle	63.5°	
Wheelbase	1,482 ± 10 mm (58.35 ± 0.39 in)	
Seat height unloaded	960 mm (37.8 in)	
Ground clearance unloaded	370 mm (14.57 in)	
Weight without fuel, approx. (All standard EXC/XC-W models)	103 kg (227 lb.)	
Weight without fuel, approx. (All Six Days models)	103.5 kg (228.2 lb.)	
Maximum permissible front axle load (All 250 models)	148 kg (326 lb.)	
Maximum permissible front axle load (All 300 models)	147 kg (324 lb.)	
Maximum permissible rear axle load	190 kg (419 lb.)	

Maximum permissible overall weight	335 kg (739 lb.)
------------------------------------	------------------

26.6 Electrical system

Battery	HJTZ5S-FP	Lithium-ion battery Battery voltage: 12 V Nominal capacity: 2.0 Ah maintenance-free
Combination instrument battery	CR 2430	Battery voltage: 3 V
Fuse	75011088005	5 A
Fuse	75011088010	10 A
Fuse	58011109120	20 A
Headlight	HS1/socket BX43t	12 V 35/35 W
Position light	W5W / socket W2.1x9.5d	12 V 5 W
Indicator lamps	W2.3W / socket W2x4.6d	12 V 2.3 W
Turn signal (All EXC models)	R10W / socket BA15s	12 V 10 W
Brake/tail light	LED	
License plate lamp (All EXC models)	LED	

26.7 Tires

Validity	Front tire	Rear tire
(All standard EXC models)	80/100 - 21 M/C 51M TT MAXXIS Maxx EnduPro	140/80 - 18 M/C 70R M+S TT MAXXIS Maxx EnduPro
(All EXC Six Days models)	90/90 - 21 M/C 54M M+S TT Metzeler MCE 6 DAYS EXTREME	140/80 - 18 M/C 70M M+S TT Metzeler MCE 6 DAYS EXTREME
(All XC-W models)	90/90 - 21 54M TT Dunlop GEOMAX AT 81 F	110/100 - 18 64M TT Dunlop GEOMAX AT 81
The tires specified represent one of the possible series production tires. Additional information is available in the Service section under: http://www.ktm.com		

26.8 Fork

26.8.1 All standard EXC/XC-W models

Fork article number	14.18.8S.63
Fork	WP SuspensionXplor 48
Compression damping	
Comfort	18 clicks
Standard	15 clicks
Sport	12 clicks
Rebound damping	
Comfort	18 clicks
Standard	15 clicks

Sport	12 clicks	
Spring length with preload spacer(s)	474 mm (18.66 in)	
Spring rate		
Weight of rider: 65 ... 75 kg (143 ... 165 lb.)	4.0 N/mm (22.8 lb/in)	
Weight of rider: 75 ... 85 kg (165 ... 187 lb.)	4.2 N/mm (24 lb/in)	
Weight of rider: 85 ... 95 kg (187 ... 209 lb.)	4.4 N/mm (25.1 lb/in)	
Fork length	928 mm (36.54 in)	
Fork oil per fork leg	642 ± 10 ml (21.71 ± 0.34 fl. oz.)	Fork oil (SAE 4) (48601166S1) (📖 p. 359)

26.8.2 All Six Days models

Fork article number	14.15.8S.63	
Fork	WP SuspensionXplor 48 PA	
Compression damping		
Comfort	18 clicks	
Standard	15 clicks	
Sport	12 clicks	
Rebound damping		
Comfort	18 clicks	
Standard	15 clicks	
Sport	12 clicks	
Spring preload - Preload Adjuster		
Comfort	+0	
Standard	+0	
Sport	+3	
Spring length with preload spacer(s)	474 mm (18.66 in)	
Spring rate		
Weight of rider: 65 ... 75 kg (143 ... 165 lb.)	4.0 N/mm (22.8 lb/in)	
Weight of rider: 75 ... 85 kg (165 ... 187 lb.)	4.2 N/mm (24 lb/in)	
Weight of rider: 85 ... 95 kg (187 ... 209 lb.)	4.4 N/mm (25.1 lb/in)	
Fork length	928 mm (36.54 in)	
Fork oil per fork leg	635 ± 10 ml (21.47 ± 0.34 fl. oz.)	Fork oil (SAE 4) (48601166S1) (📖 p. 359)

26.9 Shock absorber

Shock absorber article number	12.18.7S.63	
Shock absorber	WP Suspension 5018 PDS DCC	
Compression damping, low-speed		
Comfort	18 clicks	
Standard	15 clicks	
Sport	12 clicks	
Compression damping, high-speed		
Comfort	2.5 turns	
Standard	2 turns	

Sport	1 turn
Rebound damping	
Comfort	18 clicks
Standard	15 clicks
Sport	12 clicks
Spring preload	8 mm (0.31 in)
Spring rate	
Weight of rider: 65 ... 75 kg (143 ... 165 lb.)	57 ... 63 N/mm (325 ... 360 lb/in)
Weight of rider: 75 ... 85 kg (165 ... 187 lb.)	60 ... 66 N/mm (343 ... 377 lb/in)
Weight of rider: 85 ... 95 kg (187 ... 209 lb.)	63 ... 69 N/mm (360 ... 394 lb/in)
Spring length	225 mm (8.86 in)
Gas pressure	10 bar (145 psi)
Static sag	35 mm (1.38 in)
Riding sag	110 mm (4.33 in)
Fitted length	415 mm (16.34 in)
Shock absorber fluid (📖 p. 359)	SAE 2.5

26.10 Chassis tightening torques

Remaining screws, chassis	EJOT PT® K60x25-Z	2 Nm (1.5 lbf ft)
Screw, fuel pump	EJOT PT®	2.3 Nm (1.7 lbf ft)
Screw, intake air temperature sensor	EJOTDELTA PT® 45x12-Z	0.7 Nm (0.52 lbf ft)
Screw, oil fill level sensor	G 3/4 "	7 Nm (5.2 lbf ft)
Screw, pressure regulator	EJOT PT® K60x25-Z	2.3 Nm (1.7 lbf ft)
Screw, seat fixing	EJOTEJOFORM PT® K60x23/18	2.5 Nm (1.84 lbf ft)
Screw, emergency OFF switch (All EXC models)	M4	0.7 Nm (0.52 lbf ft)
Screw, fixed grip	M4	5 Nm (3.7 lbf ft)
		Loctite®243™
Spoke nipple, front wheel	M4.5	6 Nm (4.4 lbf ft)
Spoke nipple, rear wheel	M4.5	6 Nm (4.4 lbf ft)
Remaining nuts, chassis	M5	5 Nm (3.7 lbf ft)
Remaining screws, chassis	M5	5 Nm (3.7 lbf ft)
Screw, battery terminal	M5	2.5 Nm (1.84 lbf ft)
Screw, light switch (All EXC models)	M5	1 Nm (0.7 lbf ft)
Screw, shock absorber adjusting ring	M5	5 Nm (3.7 lbf ft)
Screw, turn signal switch (All EXC models)	M5	1 Nm (0.7 lbf ft)
Nut, cable on starter motor	M6	4 Nm (3 lbf ft)
Remaining nuts, chassis	M6	10 Nm (7.4 lbf ft)
Remaining screws, chassis	M6	10 Nm (7.4 lbf ft)
Screw, ball joint of push rod on foot brake cylinder	M6	10 Nm (7.4 lbf ft)
		Loctite®243™

Screw, chain sliding guard	M6	6 Nm (4.4 lbf ft) Loctite®243™
Screw, front brake disc	M6	14 Nm (10.3 lbf ft) Loctite®243™
Screw, manifold on silent block	M6	6 Nm (4.4 lbf ft)
Screw, oil pump	M6	7 Nm (5.2 lbf ft)
Screw, oil pump holder on oil tank	M6	6 Nm (4.4 lbf ft)
Screw, rear brake disc	M6	14 Nm (10.3 lbf ft) Loctite®243™
Screw, silent block on frame	M6	6 Nm (4.4 lbf ft)
Screw, throttle grip	M6	5 Nm (3.7 lbf ft)
Nut, foot brake lever	M8	15 Nm (11.1 lbf ft)
Nut, foot brake lever stop	M8	20 Nm (14.8 lbf ft)
Nut, pull switch (All XC-W models)	M8	0.4 Nm (0.3 lbf ft)
Nut, rear sprocket screw	M8	35 Nm (25.8 lbf ft) Loctite®2701™
Nut, rim lock	M8	12 Nm (8.9 lbf ft)
Remaining nuts, chassis	M8	25 Nm (18.4 lbf ft)
Remaining screws, chassis	M8	25 Nm (18.4 lbf ft)
Screw, bottom triple clamp (All standard EXC/XC-W models)	M8	15 Nm (11.1 lbf ft)
Screw, bottom triple clamp (All Six Days models)	M8	15 Nm (11.1 lbf ft)
Screw, chain sliding piece	M8	15 Nm (11.1 lbf ft)
Screw, engine brace	M8	25 Nm (18.4 lbf ft) Loctite®2701™
Screw, engine sprocket cover	M8	20 Nm (14.8 lbf ft)
Screw, fork stub	M8	15 Nm (11.1 lbf ft)
Screw, front brake caliper	M8	25 Nm (18.4 lbf ft) Loctite®243™
Screw, handlebar clamp	M8	20 Nm (14.8 lbf ft)
Screw, side stand attachment	M8	35 Nm (25.8 lbf ft) Loctite®2701™
Screw, subframe	M8	35 Nm (25.8 lbf ft) Loctite®2701™
Screw, top steering stem (All standard EXC/XC-W models)	M8	20 Nm (14.8 lbf ft)
Screw, top steering stem (All Six Days models)	M8	17 Nm (12.5 lbf ft) Loctite®243™
Screw, top triple clamp (All standard EXC/XC-W models)	M8	20 Nm (14.8 lbf ft)
Screw, top triple clamp (All Six Days models)	M8	17 Nm (12.5 lbf ft)
Engine bracket screw	M10	60 Nm (44.3 lbf ft)
Remaining nuts, chassis	M10	45 Nm (33.2 lbf ft)
Remaining screws, chassis	M10	45 Nm (33.2 lbf ft)
Screw, handlebar support	M10	40 Nm (29.5 lbf ft) Loctite®243™
Nut, fuel pump	M12	15 Nm (11.1 lbf ft)

Screw, bottom shock absorber	M12	80 Nm (59 lbf ft) Loctite®2701™
Screw, top shock absorber	M12	80 Nm (59 lbf ft) Loctite®2701™
Nut, swingarm pivot	M16x1.5	100 Nm (73.8 lbf ft)
Nut, rear wheel spindle	M20x1.5	80 Nm (59 lbf ft)
Screw, front wheel spindle	M20x1.5	35 Nm (25.8 lbf ft)
Screw, top steering head	M20x1.5	12 Nm (8.9 lbf ft)
Screw-in nozzles, cooling system	M20x1.5	12 Nm (8.9 lbf ft) Loctite®243™

27.1 Cleaning the motorcycle

Note

Material damage Components become damaged or destroyed if a pressure cleaner is used incorrectly. The high pressure forces water into the electrical components, connectors, throttle cables, and bearings, etc. Pressure which is too high causes malfunctions and destroys components.

- Do not direct the water jet directly on to electrical components, connectors, throttle cables or bearings.
- Maintain a minimum distance between the nozzle of the pressure cleaner and the component.
Minimum clearance 60 cm (23.6 in)



Note

Environmental hazard Hazardous substances cause environmental damage.

- Dispose of oils, grease, filters, fuel, cleaning agents, brake fluid, etc., correctly and in compliance with the applicable regulations.



Info

To maintain the value and appearance of the motorcycle over a long period, clean it regularly. Avoid direct sunshine when cleaning the motorcycle.

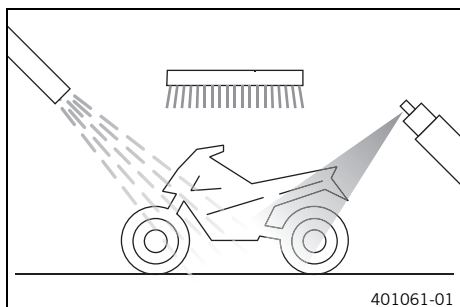

- Close off the exhaust system to keep water from entering.
- Remove coarse dirt particles with a gentle water jet.
- Spray heavily soiled parts with a normal commercial motorcycle cleaner and then brush off with a soft brush.

Motorcycle cleaner (📖 p. 361)



Info

Use warm water containing normal motorcycle cleaner and a soft sponge. Never apply motorcycle cleaner to a dry vehicle; always rinse the vehicle with water first.

- After rinsing the motorcycle with a gentle spray of water, allow it to dry thoroughly.
- Remove the closure of the exhaust system.



Warning

Danger of accidents Moisture and dirt impair the brake system.

- Brake carefully several times to dry out and remove dirt from the brake linings and the brake discs.

- After cleaning, ride the vehicle a short distance until the engine warms up.



Info

The heat produced causes water at inaccessible locations in the engine and on the brake system to evaporate.

- After the motorcycle has cooled off, lubricate all moving parts and bearings.
- Clean the chain. (📖 p. 149)

- Treat bare metal (except for brake discs and the exhaust system) with a corrosion inhibitor.

Preserving materials for paints, metal and rubber
(📖 p. 361)

- Treat all plastic parts and powder-coated parts with a mild cleaning and care product.

Special cleaner for glossy and matte paint finishes, metal and plastic surfaces (📖 p. 361)

(All EXC models)

- Oil the steering lock.

Universal oil spray (📖 p. 361)



27.2 Checks and maintenance steps for winter operation

i Info

If you use the motorcycle in winter, salt can be expected on the roads. You should therefore take precautions against aggressive road salt.

If the vehicle has been used on salted roads, use cold water for cleaning after riding. Warm water enhances the corrosive effects of salt.

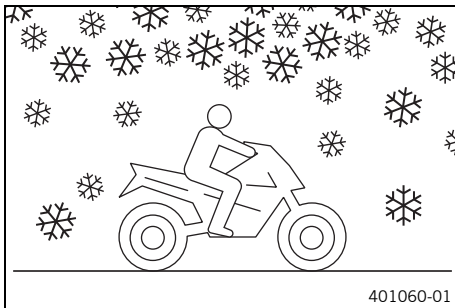

- Clean the motorcycle. (📖 p. 322)
- Clean the brakes.

i Info

After **EVERY** trip on salted roads, thoroughly wash the cool and installed brake calipers and brake linings with cold water and dry carefully.

After riding on salted roads, thoroughly wash the vehicle with cold water and dry it well.

- Treat the engine, the swingarm, and all other bare or galvanized parts (except brake discs) with a wax-based corrosion inhibitor.

i Info

Corrosion inhibitor is not permitted to come in contact with the brake discs as this would greatly reduce the braking force.

- Clean the chain. (📖 p. 149)



28.1 Storage



Warning

Danger of poisoning Fuel is poisonous and a health hazard.

- Avoid skin, eye and clothing contact with fuel.
- Immediately consult a doctor if you swallow fuel.
- Do not inhale fuel vapors.
- In case of skin contact, rinse the affected area with plenty of water.
- Rinse the eyes thoroughly with water, and consult a doctor in case of fuel contact with the eyes.
- Change your clothing in case of fuel spills on them.
- Keep fuels correctly in a suitable canister, and out of the reach of children.



Info

If you plan to garage the motorcycle for a longer period, perform the following steps or have them performed.

Before storing the motorcycle, check all parts for function and wear. If service, repairs, or replacements are necessary, you should do this during the storage period (less workshop overload). In this way, you can avoid long workshop waiting times at the start of the new season.

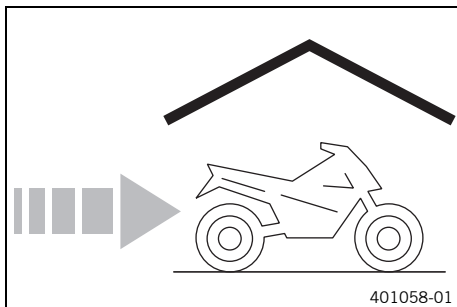

- Clean the motorcycle. (📖 p. 322)
- Change the gear oil. (📖 p. 294)
- Check the antifreeze and coolant level. (📖 p. 286)
- When refueling for the last time before taking the motorcycle out of service, add fuel additive.

Fuel additive (📖 p. 360)

- Refuel.
- Add 2-stroke oil. (📖 p. 297)
- Check the tire air pressure. (📖 p. 137)
- Remove the battery. (📖 p. 161)
- Recharge the battery.

Guideline

Ideal charging and storage temperature of the lithium-ion battery	10 ... 20 °C (50 ... 68 °F)
---	-----------------------------

- Store the vehicle in a dry location that is not subject to large fluctuations in temperature.



Info

KTM recommends jacking up the motorcycle.

- Raise the motorcycle with a lift stand. (📖 p. 12)
- Cover the vehicle with a tarp or similar cover that is permeable to air.

**Info**

Do not use non-porous materials since they prevent humidity from escaping, thus causing corrosion. Avoid running the engine for a short time only. Because the engine will not warm up sufficiently, the water vapor produced during combustion will condense, causing engine parts and the exhaust system to rust.

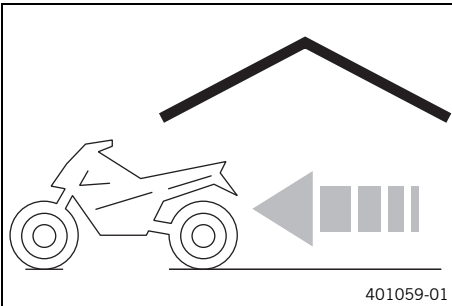
**28.2 Preparing for use after storage**

- Remove the motorcycle from the lift stand. (📖 p. 12)
- Install the battery. (📖 p. 162)
- Perform checks and maintenance measures when preparing for use.
- Make a test ride.



29.1 Additional information

Any further work that results from the compulsory work or from the recommended work must be ordered separately and invoiced separately.

Different service intervals may apply in your country, depending on the local operating conditions.

Individual service intervals and scopes may change in the course of technical developments. The most up-to-date service schedule can always be found on KTM Dealer.net. Your authorized KTM dealer will be happy to advise you.

29.2 Required work

	Every 10 operating hours when used for motorsports	Every 40 operating hours	Every 20 operating hours	Once after 5 operating hours	Once after 1 operating hour
Read out the fault memory using the KTM diagnostics tool.	○	○	●	●	●
Check that the electrical system is functioning properly.	○		●	●	●
Check and charge the battery.			●	●	●
Check the front brake linings. (🔧 p. 167)			●	●	●
Check the brake linings of the rear brake. (🔧 p. 174)			●	●	●
Check the brake discs. (🔧 p. 139)			●	●	●
Check the brake lines for damage and leakage.			●	●	●
Check the rear brake fluid level. (🔧 p. 178)			●	●	●
Check the free travel of the foot brake lever. (🔧 p. 176)			●	●	●
Check the frame. (🔧 p. 74)			●	●	●
Check the swingarm. (🔧 p. 101)			●	●	●
Check the swingarm bearing for backlash. (🔧 p. 105)			●	●	
Check the heim joint for play. (🔧 p. 101)			●	●	
Check the tire condition. (🔧 p. 137)	○		●	●	●
Check the tire air pressure. (🔧 p. 137)	○		●	●	●
Check the wheel bearing for play. (🔧 p. 138)			●	●	●
Check the wheel hubs.			●	●	●
Check the rim run-out. (🔧 p. 139)	○		●	●	
Check the spoke tension. (🔧 p. 140)	○		●	●	●
Check the chain, rear sprocket, engine sprocket, and chain guide. (🔧 p. 151)			●	●	●
Check the chain tension. (🔧 p. 150)	○		●	●	●
Grease all moving parts (e.g. side stand, hand lever, chain, etc.) and check for smooth operation.			●	●	●
Check/correct the fluid level of the hydraulic clutch. (🔧 p. 275)			●	●	●
Check the front brake fluid level. (🔧 p. 170)			●	●	●
Check the free travel of the hand brake lever. (🔧 p. 169)			●	●	●
Check the play of the steering head bearing. (🔧 p. 65)	○		●	●	
Change the spark plug and spark plug connector. (🔧 p. 307)					●
Check the reed valve housing, reed valve, and intake flange. (🔧 p. 235)			●	●	
Change the gear oil. (🔧 p. 294)		○			●
Check all hoses (e.g. fuel, cooling, bleeder, drainage, etc.) and sleeves for cracking, leaks, and incorrect routing.	○		●	●	●

	Every 10 operating hours when used for motorsports	Every 40 operating hours	Every 20 operating hours	Once after 5 operating hours	Once after 1 operating hour
Check the antifreeze and coolant level. (🔧 p. 286)	○	●	●	●	●
Check the cables for damage and for routing without kinks.		●	●	●	
Check that the throttle cables are undamaged, routed without sharp bends, and set correctly.	○	●	●	●	
Clean the air filter and air filter box. (🔧 p. 118)		●	●	●	
Change glass fiber yarn filling in the main silencer. (🔧 p. 114)		●	●		
Service the fork. (🔧 p. 20)					●
Service the shock absorber. (🔧 p. 83)					●
Check the screws and nuts for tightness.	○	●	●	●	
Change the fuel screen. (🔧 p. 125)	○	●	●	●	
Check the fuel pressure. (🔧 p. 132)		●	●	●	
Check the headlight setting. (🔧 p. 183)	○	●	●	●	
Check idle.		●	●	●	
Final check: Check the vehicle for operating safety and take a test ride.	○	○	●	●	●
Read out the error memory after the test ride using the KTM diagnostics tool.	○	○	●	●	●
Make the service entry in the KTM Dealer.net and in the Service and Warranty Booklet.	○	○	●	●	●

- One-time interval
- Periodic interval

29.3 Recommended work

	Every 40 operating hours when used for motorsports	Every 10 operating hours when used for motorsports	Annually	Every 80 operating hours	Every 40 operating hours	Once after 20 operating hours	Once after 10 operating hours
Change the front brake fluid. (🔧 p. 172)			●				
Change the rear brake fluid. (🔧 p. 179)			●				
Change the hydraulic clutch fluid. (🔧 p. 276)			●				
Lubricate the steering head bearing. (🔧 p. 61)			●				
Clean the pressure sensor hose. (🔧 p. 190)			●	●	●		
Service the fork. (🔧 p. 20)	○						
Service the shock absorber. (🔧 p. 83)		○					
Check the electric starter drive. (🔧 p. 249)			●				●
Change the fuel filter. (🔧 p. 126)			●				●
Change the piston and check the cylinder.			●				●
Replace the oil pump. (🔧 p. 299)			●				
Perform minor engine service. (Check the exhaust control for functioning and smooth operation. Check the clutch.)			●	●		●	●

29 SERVICE SCHEDULE

	Every 40 operating hours when used for motorsports	Every 10 operating hours when used for motorsports	Annually	Every 80 operating hours	Every 40 operating hours	Once after 20 operating hours	Once after 10 operating hours
Perform major engine service including removing and installing engine. (Change the connecting rod, conrod bearing, and crank pin. Clean the pressure sensor cylinder connection. Check the transmission and shift mechanism. Change all engine bearings.)						•	•

- One-time interval
- Periodic interval

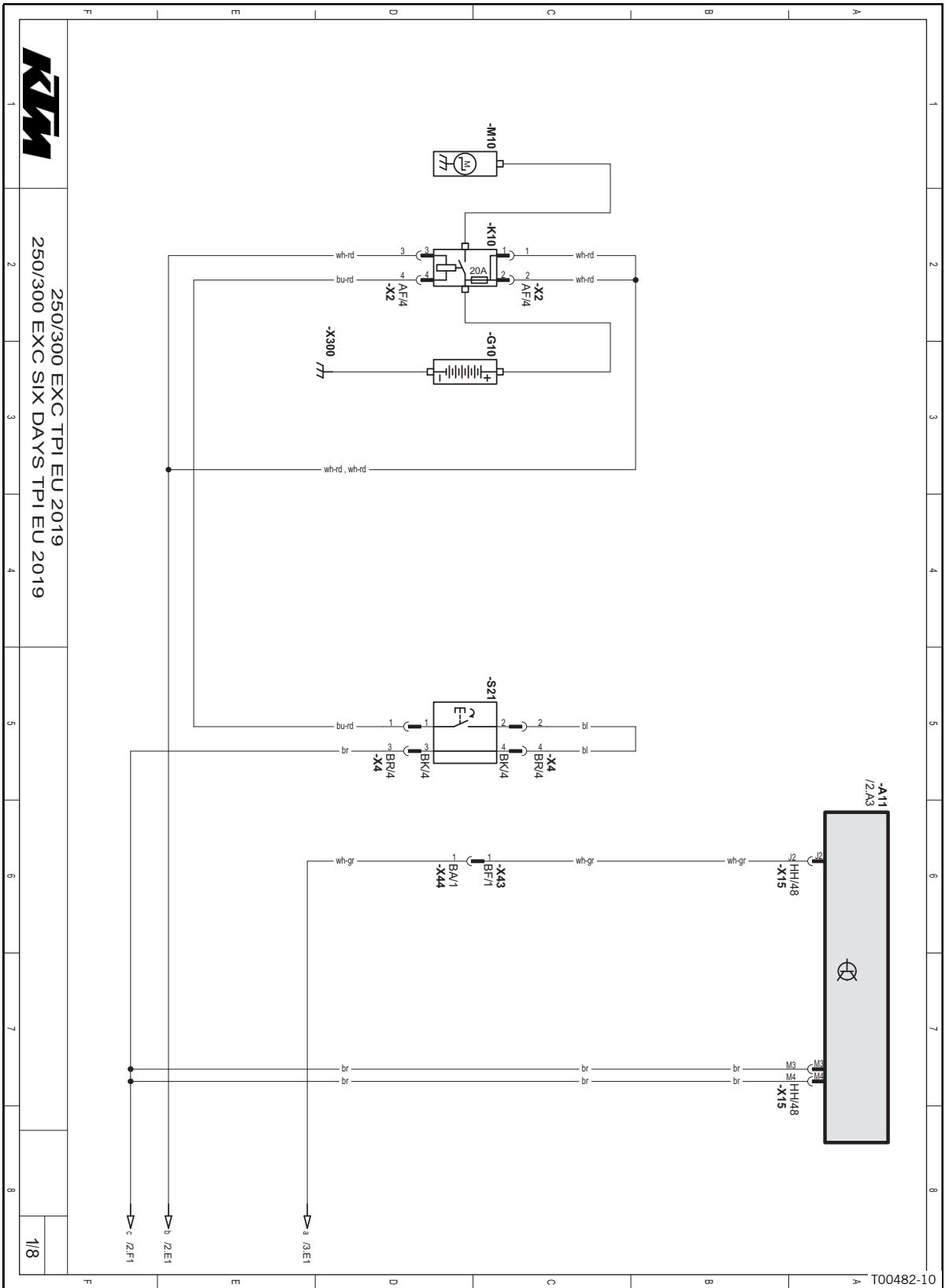

Components:

A11	EFI control unit
G10	Battery
K10	Starter relay with main fuse
M10	Electric starter system
S21	E-tip switch

30.2 Page 2 of 8 (All EXC models)

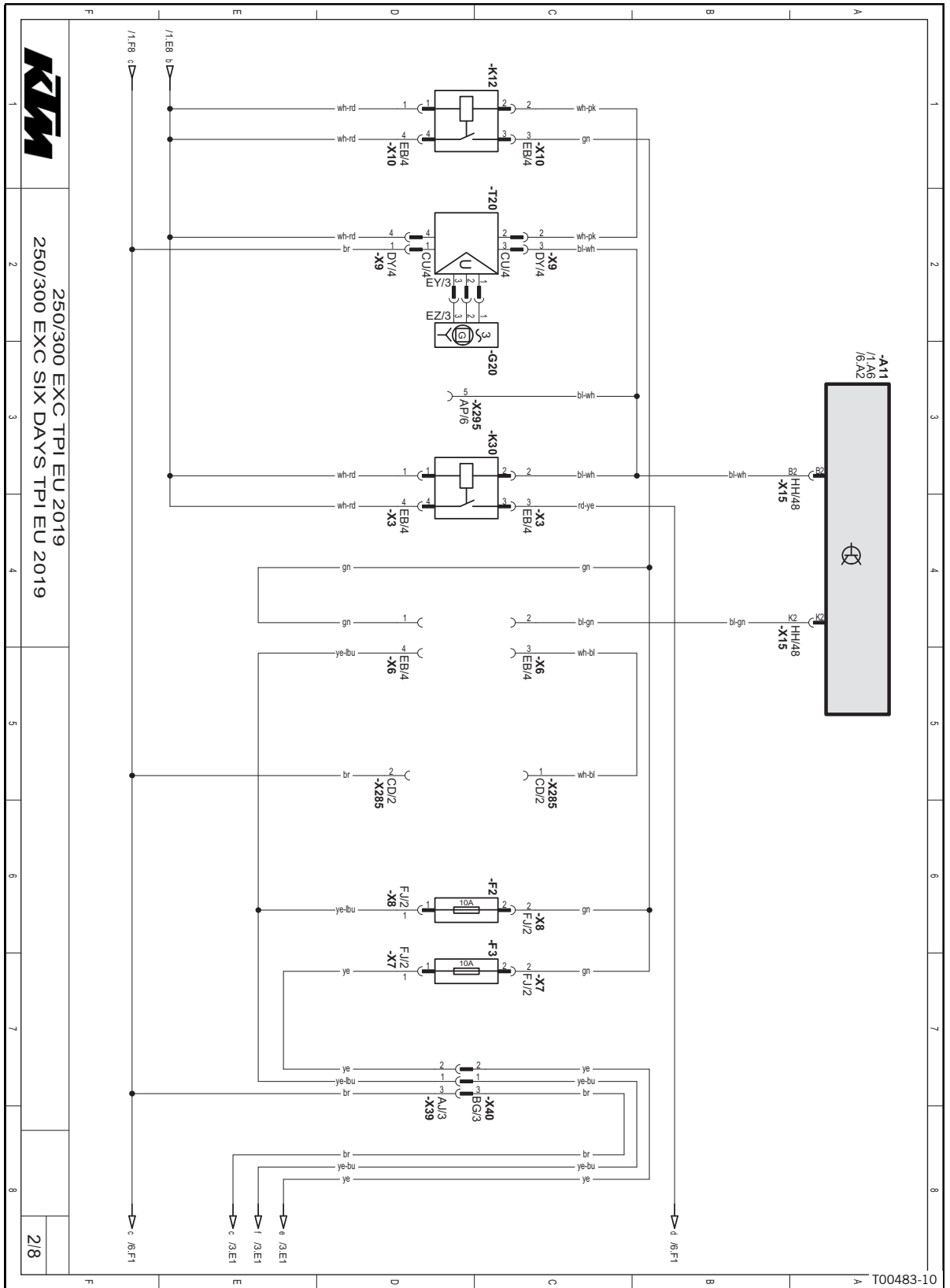

Components:

A11	EFI control unit
F2	Fuse
F3	Fuse
G20	Alternator
K12	Light relay
K30	Power relay
T20	Voltage regulator
X285	Radiator fan connector
X295	Diagnostics connector

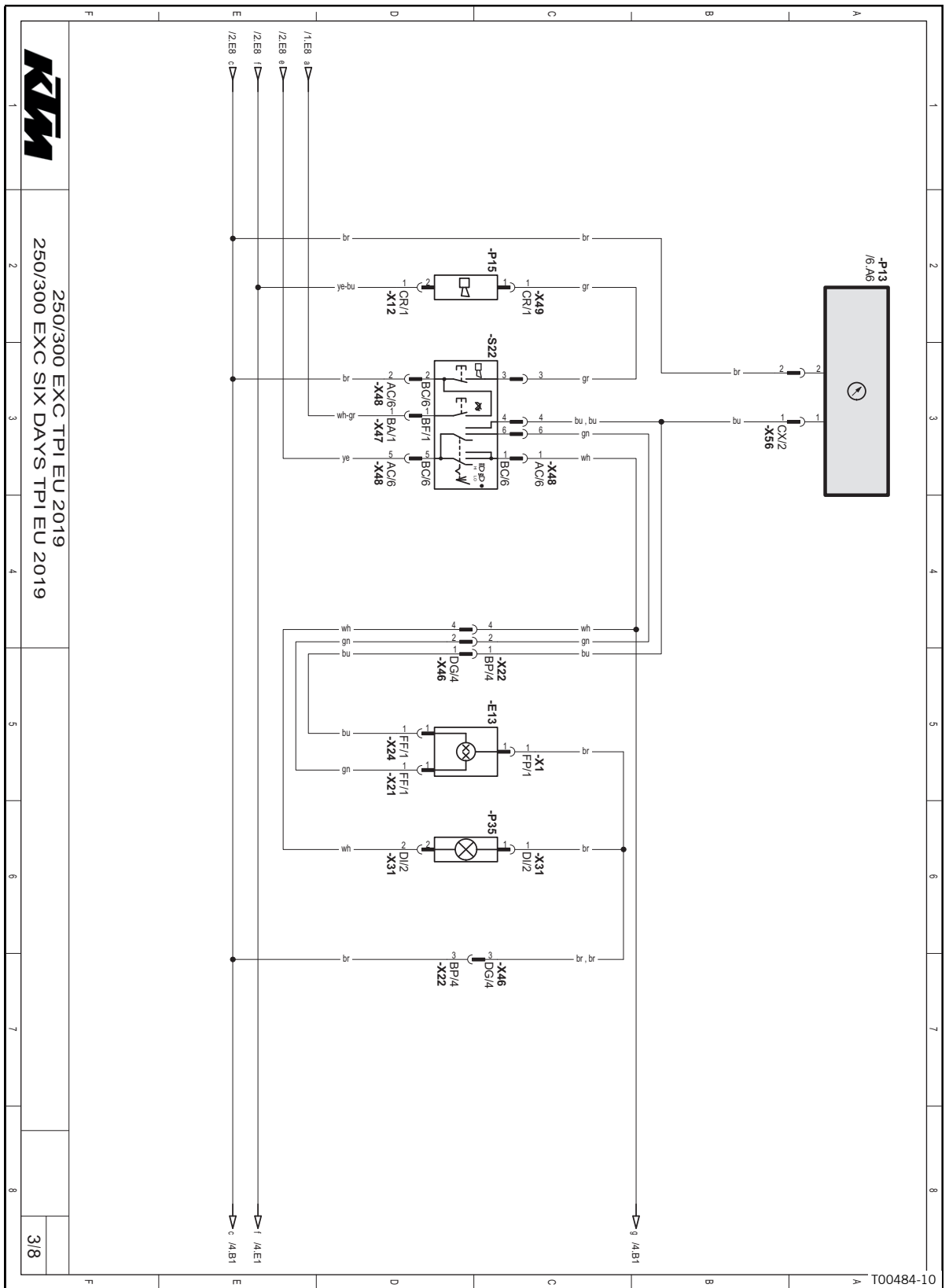

Components:

E13	Low beam, high beam
P13	Speedometer
P15	Horn
P35	Parking light
S22	Light switch, horn button, kill switch

30.4 Page 4 of 8 (All EXC models)

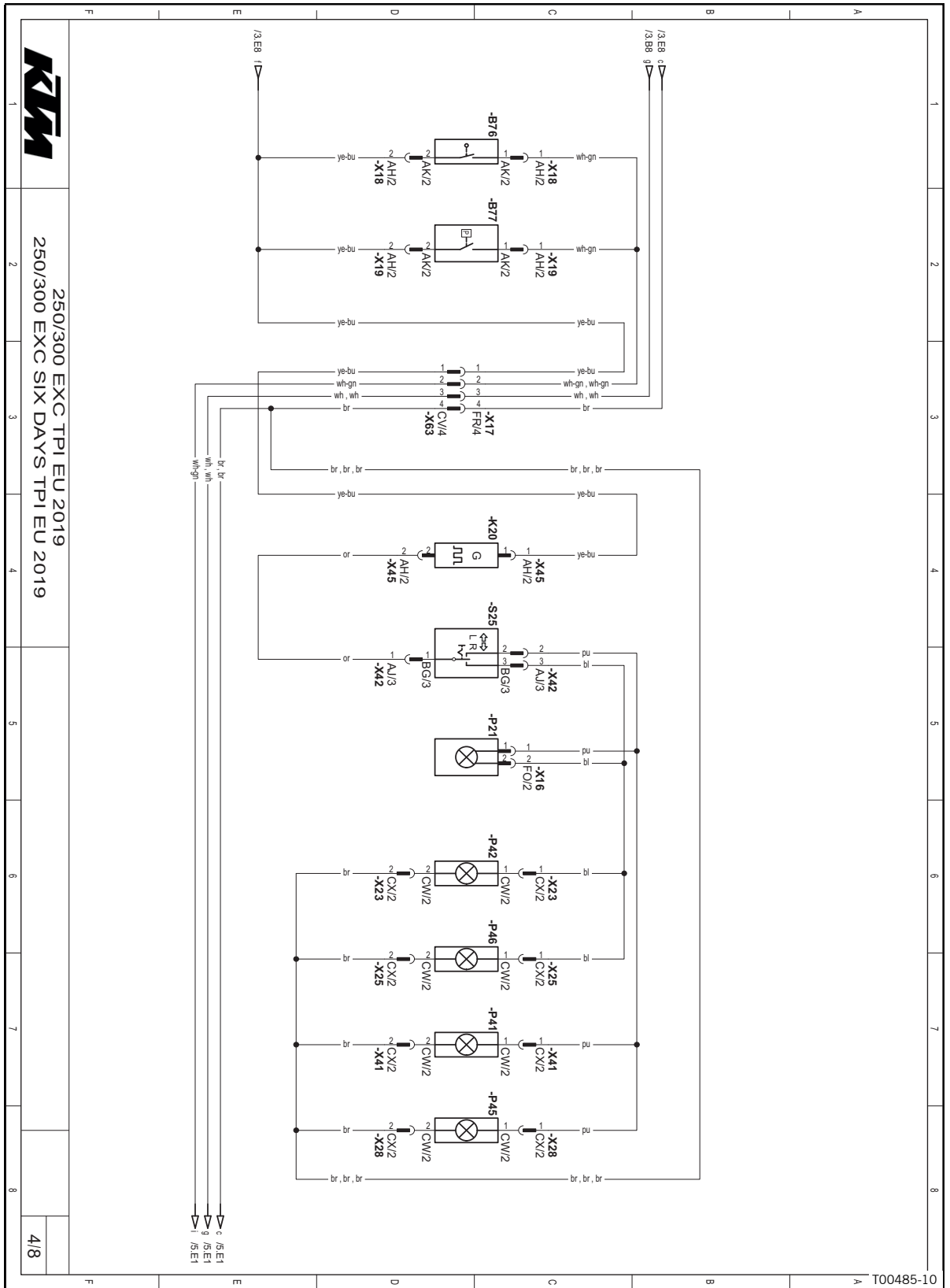

Components:

B76	Front brake light switch
B77	Rear brake light switch
K20	Turn signal relay
P21	Turn signal indicator lamp
P41	Turn signal, front left
P42	Turn signal, front right
P45	Turn signal, rear left
P46	Turn signal, rear right
S25	Turn signal switch

Components:

E60 License plate lamp

P36 Brake/tail light

30.6 Page 6 of 8 (All EXC models)

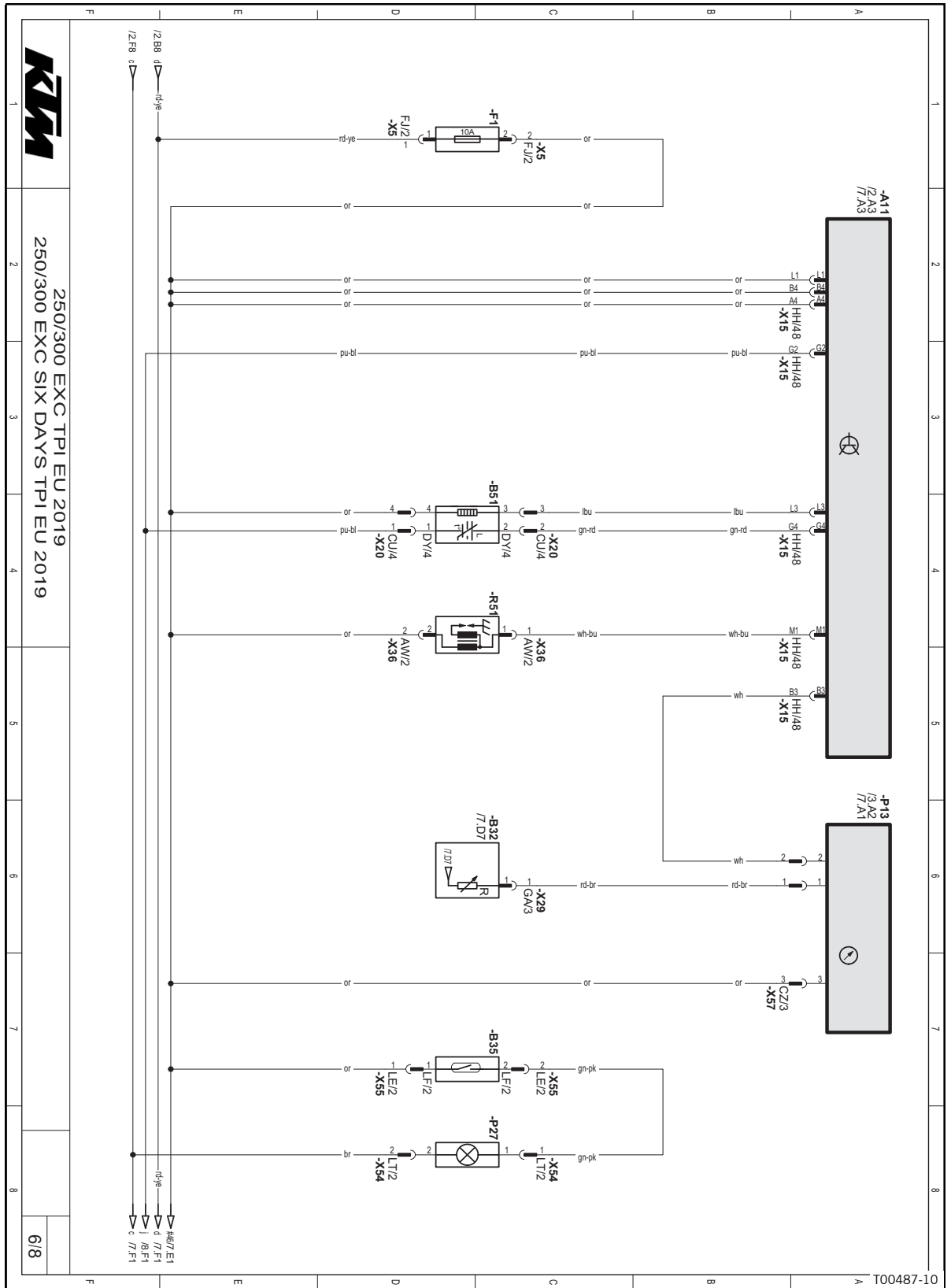

Components:

A11	EFI control unit
B32	Fuel level sensor
B35	Oil level sensor
B51	Lambda sensor
F1	Fuse
P13	Speedometer
P27	Oil level warning lamp
R51	Ignition coil

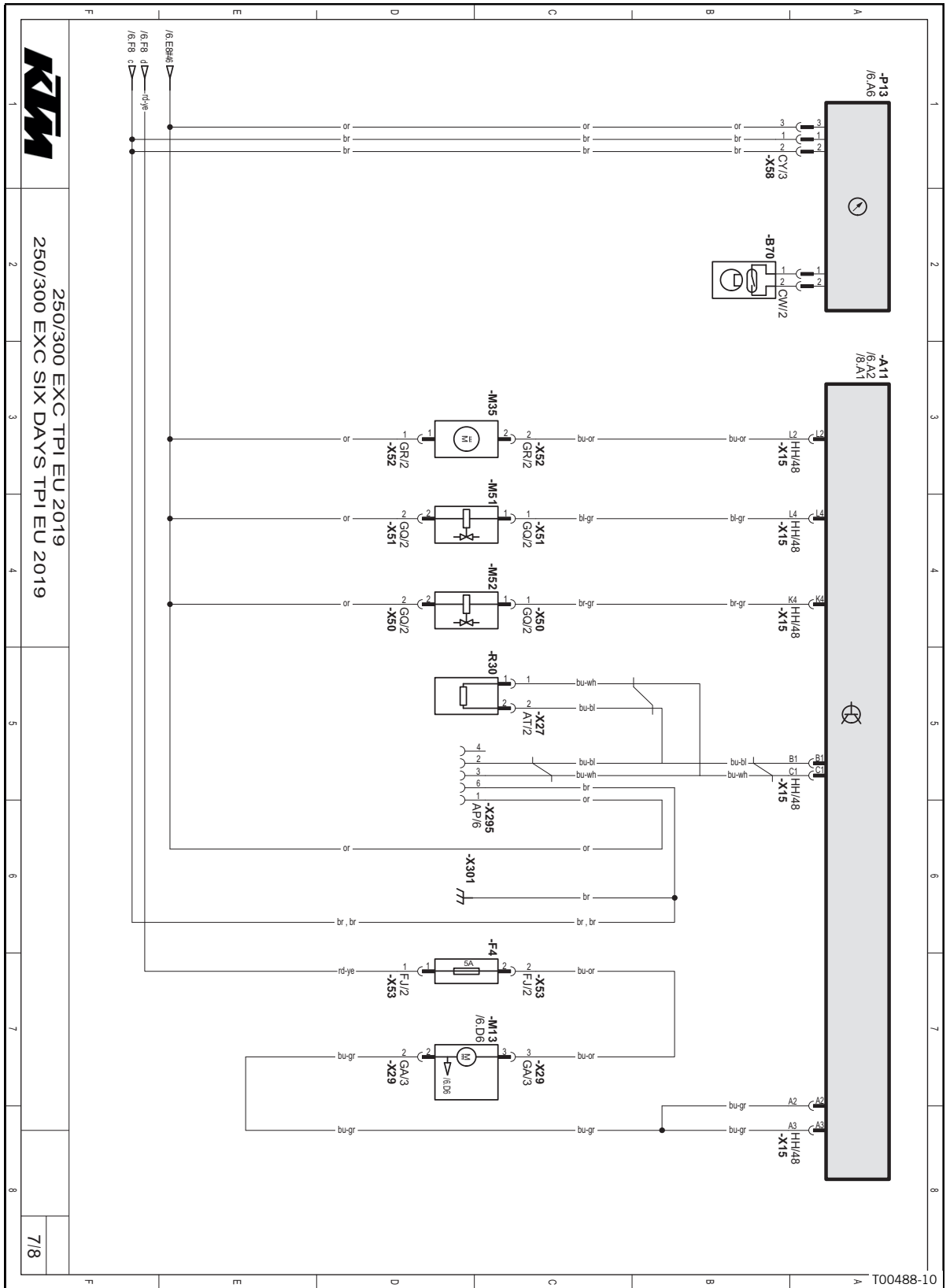

Components:

A11	EFI control unit
B70	Front wheel speed sensor
F4	Fuse
M13	Fuel pump
M35	Oil pump
M51	Injection valve 0
M52	Injection valve 1
P13	Speedometer
R30	CAN-bus terminating resistor 1
X295	Diagnostics connector

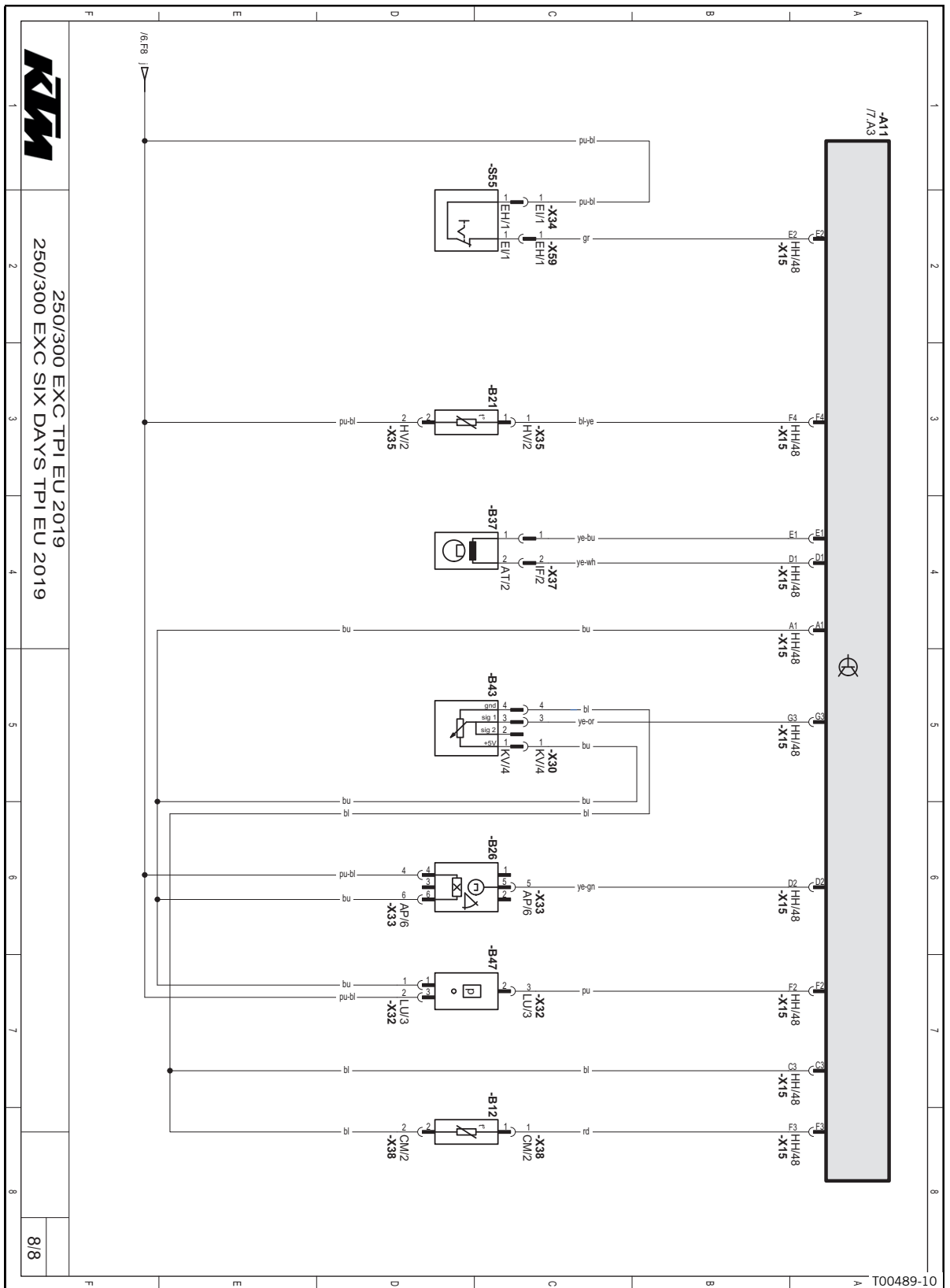

Components:

A11	EFI control unit
B12	Intake air temperature sensor
B21	Engine coolant temperature sensor
B26	Rollover sensor
B37	Crankshaft speed sensor
B43	Throttle valve position sensor
B47	Crankcase pressure sensor
S55	Map-Select switch (optional)

Cable colors:

bl	Black
br	Brown
bu	Blue
gn	Green
gr	Gray
lbu	Light blue
or	Orange
pk	Pink
pu	Violet
rd	Red
wh	White
ye	Yellow

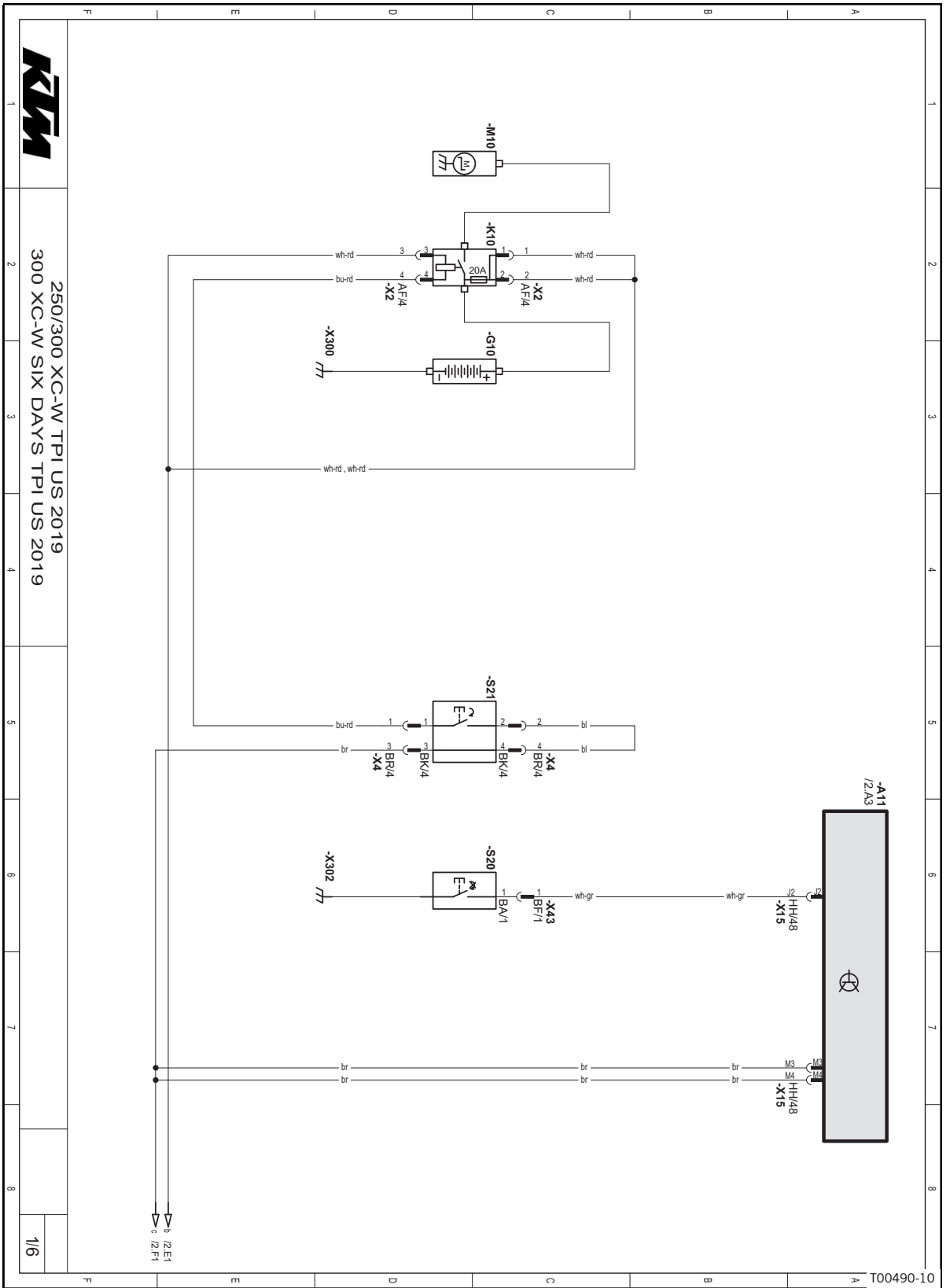

Components:

A11	EFI control unit
G10	Battery
K10	Starter relay with main fuse
M10	Electric starter system
S21	E-tip switch
S20	Kill switch

Components:

A11	EFI control unit
F2	Fuse
F3	Fuse
G20	Alternator
K12	Light relay
K30	Power relay
T20	Voltage regulator
X285	Radiator fan connector
X295	Diagnostics connector

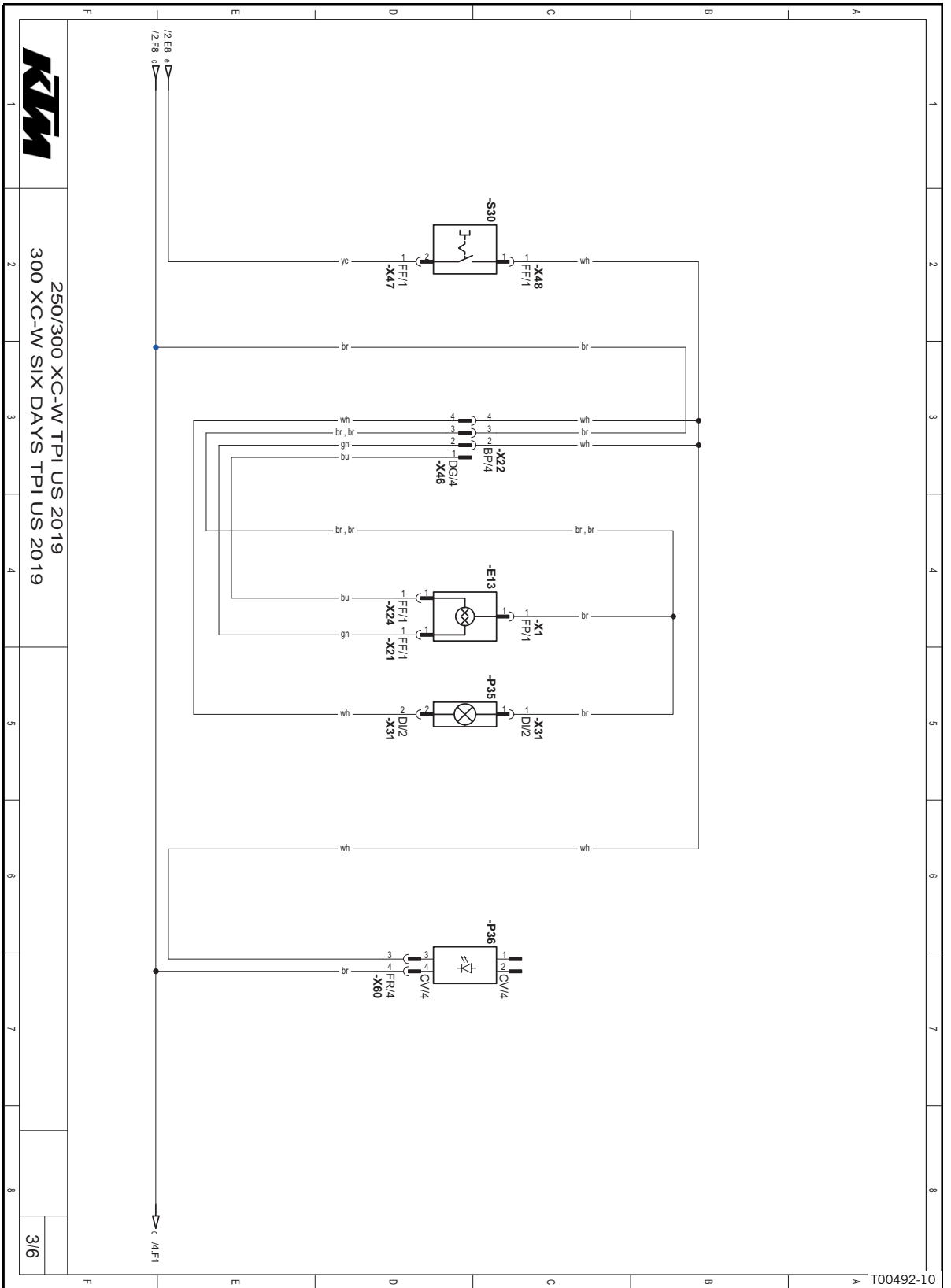

Components:

E13	Low beam, high beam
P35	Parking light
P36	Brake/tail light
S30	Light switch

30.12 Page 4 of 6 (All XC-W models)

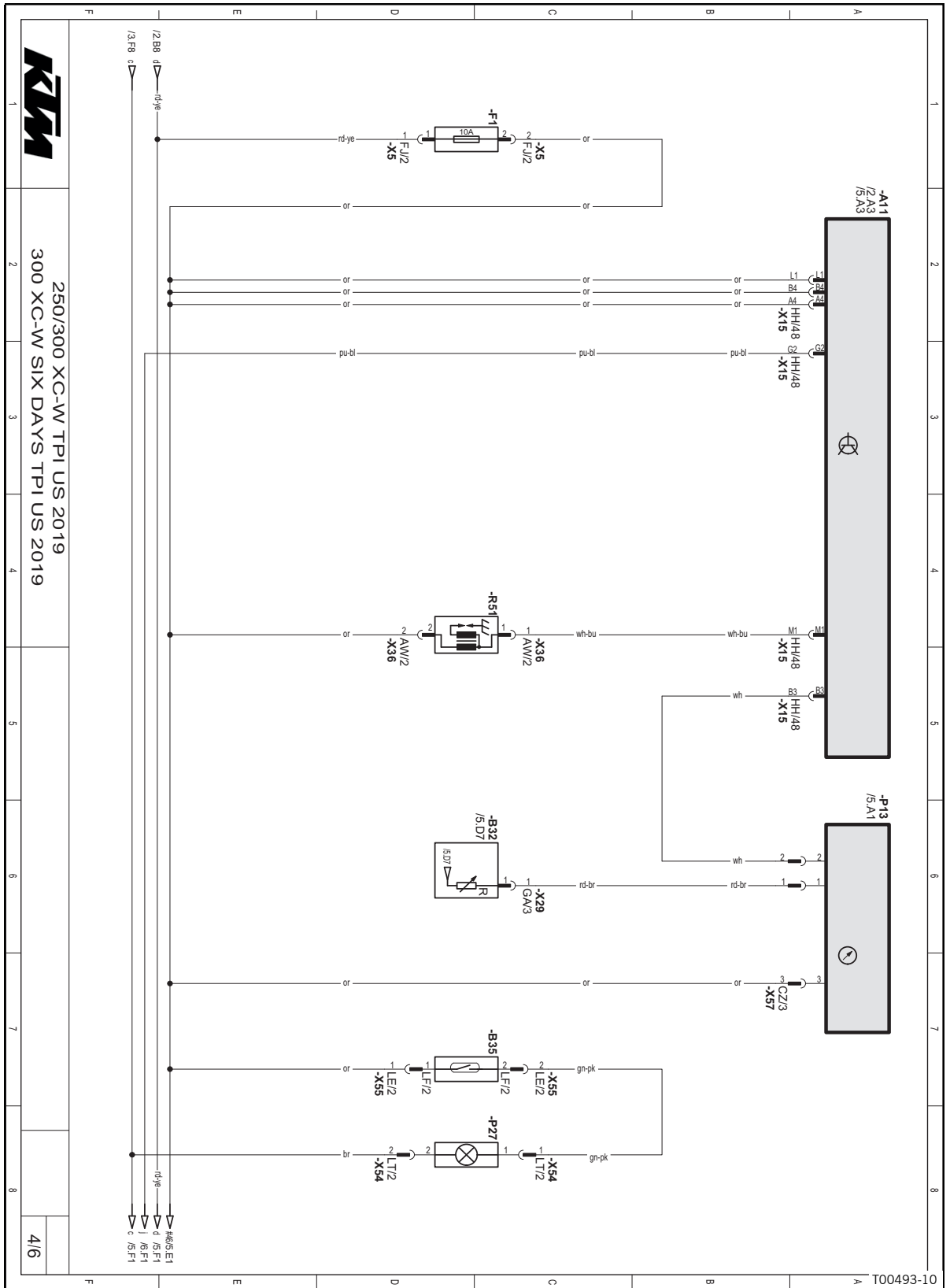

Components:

A11	EFI control unit
B32	Fuel level sensor
B35	Oil level sensor
F1	Fuse
P13	Speedometer
P27	Oil level warning lamp
R51	Ignition coil

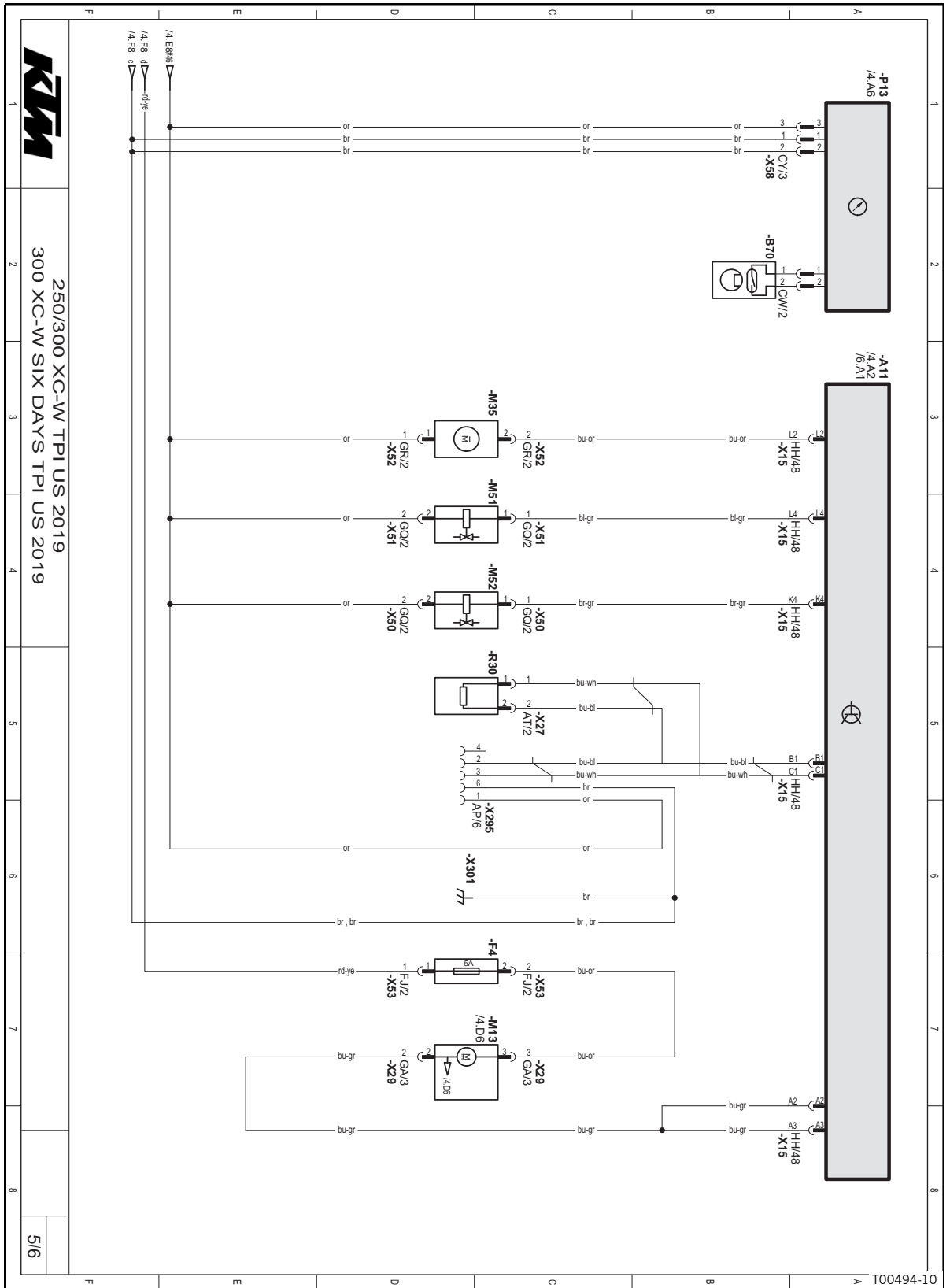

Components:

A11	EFI control unit
B70	Front wheel speed sensor
F4	Fuse
M13	Fuel pump
M35	Oil pump
M51	Injection valve 0
M52	Injection valve 1
P13	Speedometer
R30	CAN-bus terminating resistor 1
X295	Diagnostics connector

Components:

A11	EFI control unit
B12	Intake air temperature sensor
B21	Engine coolant temperature sensor
B26	Rollover sensor
B37	Crankshaft speed sensor
B43	Throttle valve position sensor
B47	Crankcase pressure sensor
S55	Map-Select switch (optional)

Cable colors:

bl	Black
br	Brown
bu	Blue
gn	Green
gr	Gray
lbu	Light blue
or	Orange
pk	Pink
pu	Violet
rd	Red
wh	White
ye	Yellow

Brake fluid DOT 4 / DOT 5.1**Standard/classification**

- DOT

Guideline

- Use only brake fluid that complies with the specified standard (see specifications on the container) and that exhibits the corresponding properties.

Recommended supplier**Castrol**

- **REACT PERFORMANCE DOT 4**

Motorex®

- **Brake Fluid DOT 5.1**

Coolant**Guideline**

- Only use high-grade, silicate-free coolant with corrosion inhibitor additive for aluminum motors. Low grade and unsuitable antifreeze causes corrosion, deposits and frothing.
- Do not use pure water as only coolant is able to meet the requirements needed in terms of corrosion protection and lubrication properties.
- Only use coolant that complies with the requirements stated (see specifications on the container) and that has the relevant properties.

Antifreeze protection to at least	–25 °C (–13 °F)
-----------------------------------	-----------------

The mixture ratio must be adjusted to the necessary antifreeze protection. Use distilled water if the coolant needs to be diluted.

The use of premixed coolant is recommended.

Observe the coolant manufacturer specifications for antifreeze protection, dilution and miscibility (compatibility) with other coolants.

Recommended supplier**Motorex®**

- **COOLANT M3.0**

Engine oil (15W/50)**Standard/classification**

- JASO T903 MA2 (📖 p. 377)
- SAE (📖 p. 377) (15W/50)

Guideline

- Use only engine oils that comply with the specified standards (see specifications on the container) and that possess the corresponding properties.

Recommended supplier**Motorex®**

- **Top Speed 4T**

Engine oil, 2-stroke**Standard/classification**

- JASO FD (📖 p. 377)

Guideline

- Only use high grade 2-stroke engine oil of a reputable brand.

Fully synthetic

Recommended supplier

Motorex®

- Cross Power 2T

Fork oil (SAE 4) (48601166S1)**Standard/classification**

- SAE (📖 p. 377) (SAE 4)

Guideline

- Use only oils that comply with the specified standards (see specifications on the container) and that exhibit the corresponding properties.

Shock absorber fluid (SAE 2.5) (50180751S1)**Standard/classification**

- SAE (📖 p. 377) (SAE 2.5)

Guideline

- Use only oils that comply with the specified standards (see specifications on the container) and that exhibit the corresponding properties.

Super unleaded (ROZ 95/RON 95/PON 91)**Standard/classification**

- DIN EN 228 (ROZ 95/RON 95/PON 91)

Guideline

- Only use unleaded super fuel that matches or is equivalent to the specified fuel grade.
- Fuel with an ethanol content of up to 10 % (E10 fuel) is safe to use.

**Info**

Do **not** use fuel containing methanol (e. g. M15, M85, M100) or more than 10 % ethanol (e. g. E15, E25, E85, E100).

Air filter cleaner

Recommended supplier

Motorex®

- Racing Bio Dirt Remover

Chain cleaner

Recommended supplier

Motorex®

- Chain Clean

Fuel additive

Recommended supplier

Motorex®

- Fuel Stabilizer

High viscosity grease

Recommended supplier

SKF®

- LGHB 2

Long-life grease

Recommended supplier

Motorex®

- Bike Grease 2000

Lubricant (T158)

Recommended supplier

Lubcon®

- Turmogrease® PP 300

Lubricant (T14034)

Recommended supplier

WP Performance Systems

- WP Racing Grease IPR 2

Lubricant (T625)

Recommended supplier

Molykote®

- 33 Medium

Lubricant (T159)

Recommended supplier

Bel-Ray®

- MC-11®

Motorcycle cleaner

Recommended supplier

Motorex®

- Moto Clean

Multi-purpose grease (00062010051)

Recommended supplier

Klüber Lubrication®

- CENTOPLEX 2 EP

Off-road chain spray

Recommended supplier

Motorex®

- Chainlube Offroad

Oil for foam air filter

Recommended supplier

Motorex®

- Racing Bio Liquid Power

Preserving materials for paints, metal and rubber

Recommended supplier

Motorex®

- Moto Protect

Special cleaner for glossy and matte paint finishes, metal and plastic surfaces

Recommended supplier

Motorex®

- Quick Cleaner

Universal oil spray

Recommended supplier

Motorex®

- Joker 440 Synthetic

Bleeder cover

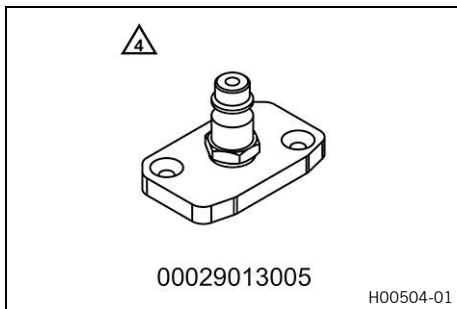

Art. no.: 00029013005

Bleeder cover

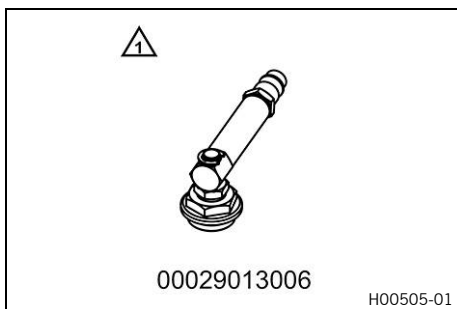

Art. no.: 00029013006

Bleeding device

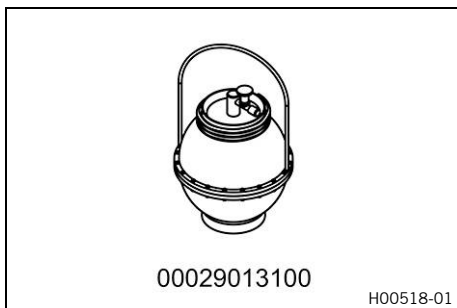

Art. no.: 00029013100

EU battery charger XCharge-professional

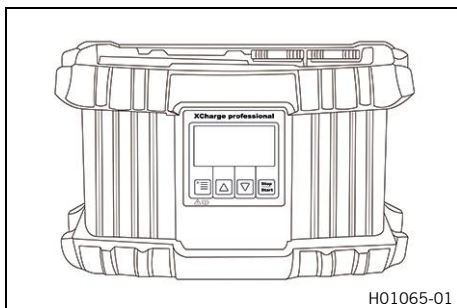

Art. no.: 00029095050

Feature

EU safety plug	
Nominal voltage	230 V
Mains fuse	16 A
Power cable length approx.	5 m (16 ft)
Charger cable length approx.	5 m (16 ft)

US battery charger XCharge-professional

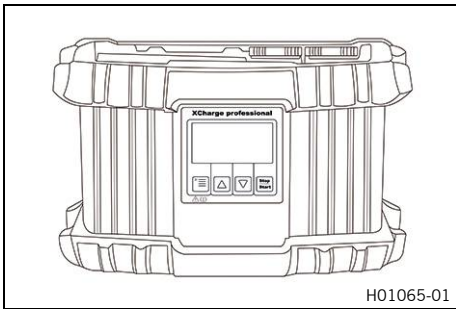

H01065-01

Art. no.: 00029095051

Feature

US plug	
Nominal voltage	120 V
Mains fuse	32 A
Power cable length approx.	5 m (16 ft)
Charger cable length approx.	5 m (16 ft)

UK battery charger XCharge-professional

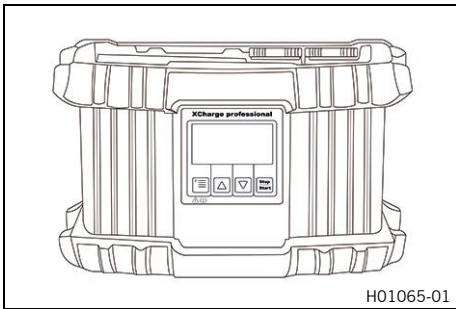

H01065-01

Art. no.: 00029095052

Feature

UK safety plug	
Nominal voltage	230 V
Mains fuse	16 A
Power cable length approx.	5 m (16 ft)
Charger cable length approx.	5 m (16 ft)

CH battery charger XCharge-professional

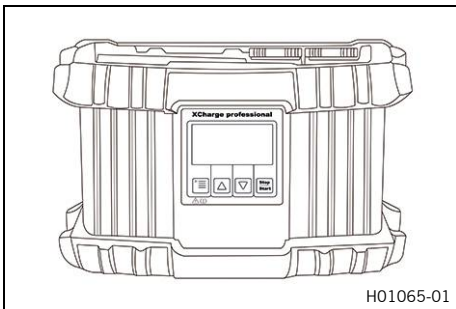

H01065-01

Art. no.: 00029095053

Feature

CH plug	
Nominal voltage	230 V
Mains fuse	16 A
Power cable length approx.	5 m (16 ft)
Charger cable length approx.	5 m (16 ft)

Tachometer

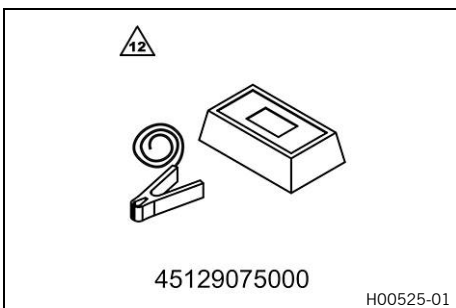

45129075000

H00525-01

Art. no.: 45129075000

Syringe

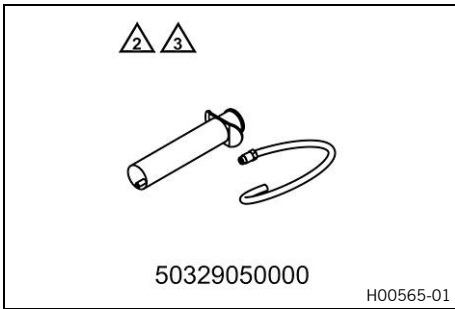

Art. no.: 50329050000

Pressing tool

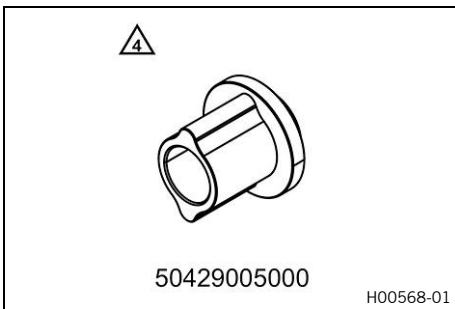

Art. no.: 50429005000

Holding wrench

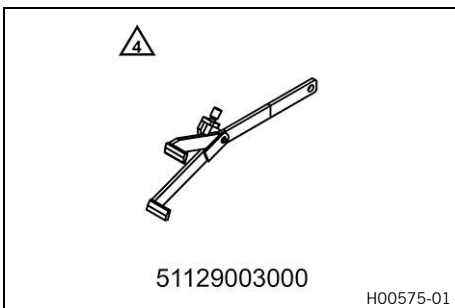

Art. no.: 51129003000

Holding wrench

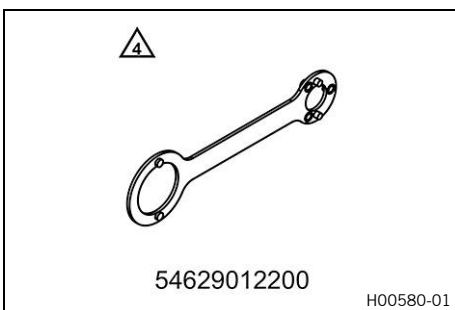

Art. no.: 54629012200

Setting gauge

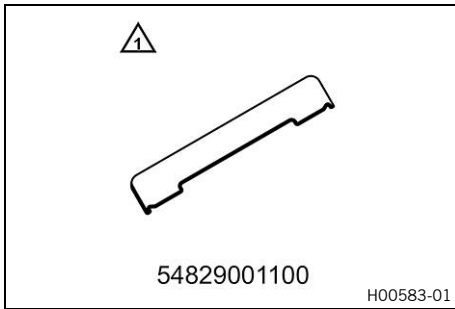

Art. no.: 54829001100

Separator plate

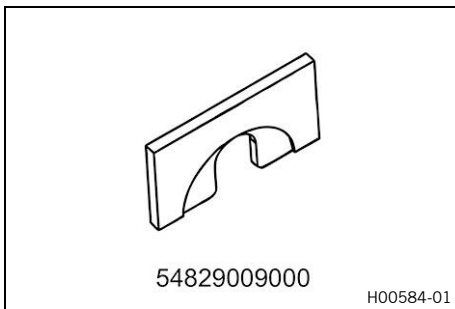

Art. no.: 54829009000

Crankshaft pressing tool insert



Art. no.: 54829108000

Holder and fitting for work stand

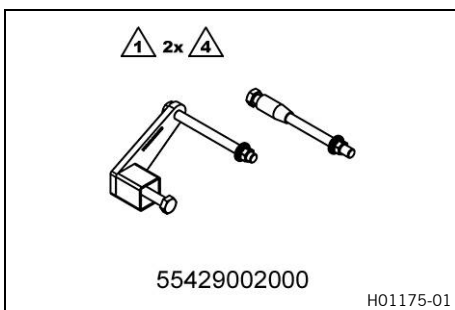

Art. no.: 55429002000

Holding wrench

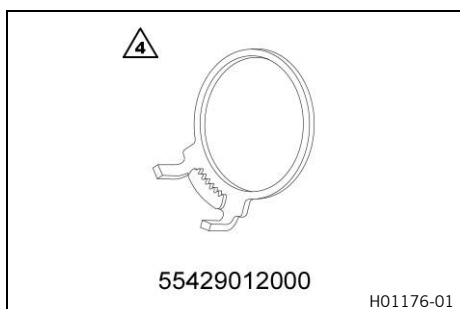

Art. no.: 55429012000

Socket wrench

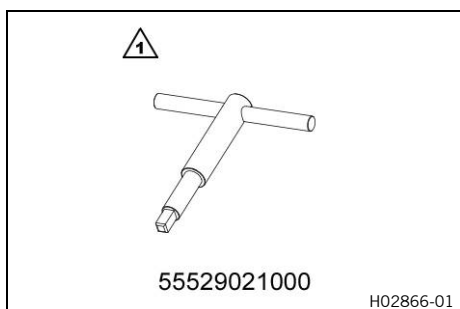

Art. no.: 55529021000

Feature

Square	5 mm (0.2 in)
--------	---------------

Adjusting gauge

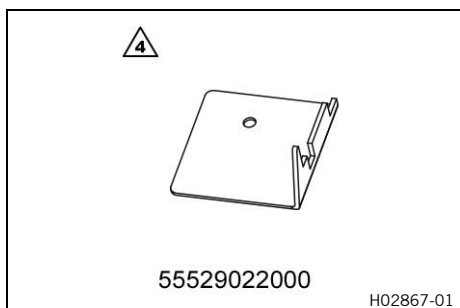

Art. no.: 55529022000

Gear segment

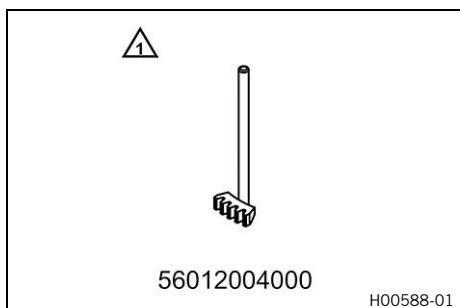

Art. no.: 56012004000

Puller

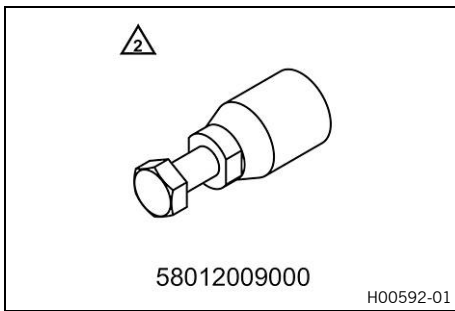

Art. no.: 58012009000

Puller

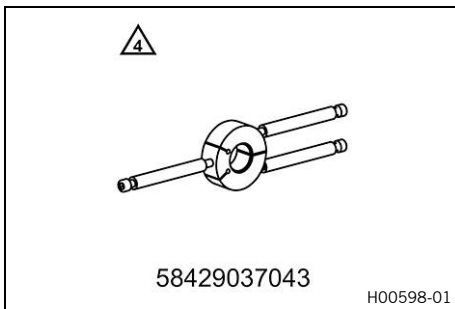

Art. no.: 58429037043

Feature

Inside diameter	43.9 mm (1.728 in)
-----------------	--------------------

Peak voltage adapter

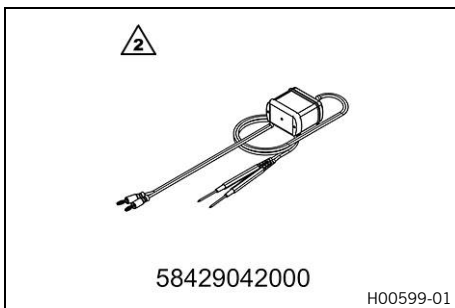

Art. no.: 58429042000

Footrest spring plier

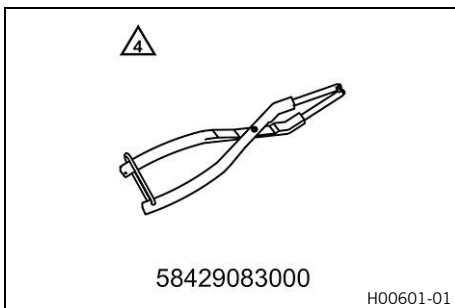

Art. no.: 58429083000

Tool bracket

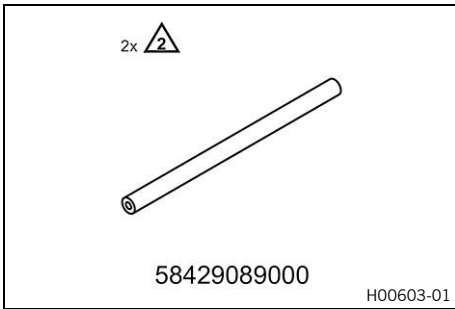

Art. no.: 58429089000

Pressing tool

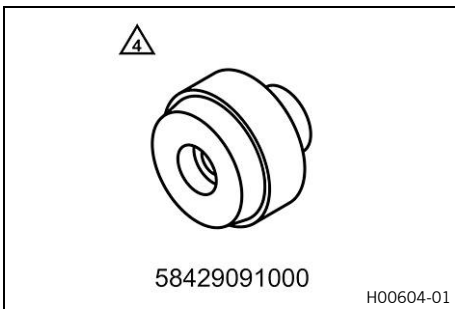

Art. no.: 58429091000

Pressing tool



Art. no.: 58429092000

Torque wrench kit

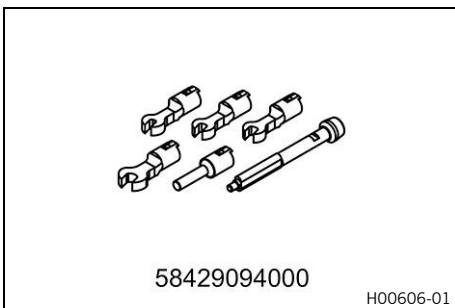

Art. no.: 58429094000

Feature

Torque	3 ... 15 Nm (2.2 ... 11.1 lbf ft)
Open ended bit	3.9 mm (0.154 in)
Open ended bit	4.9 mm (0.193 in)
Open ended bit	5.5 mm (0.217 in)
Open ended bit	6.8 mm (0.268 in)
Bit diameter	5.9 mm (0.232 in)

Feeler gauge

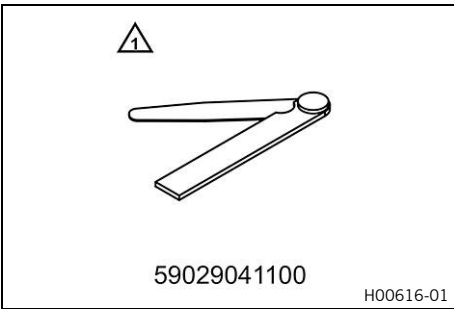

Art. no.: 59029041100

Feature

5 piece	0.10 ... 0.25 mm (0.0039 ... 0.0098 in)
---------	---

Hose clamp plier

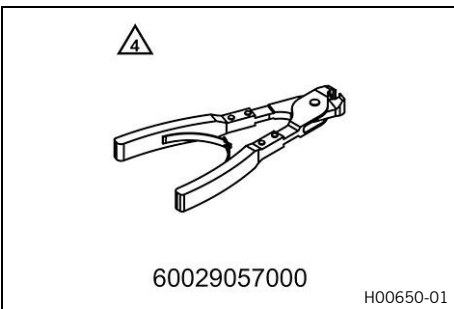

Art. no.: 60029057000

Testing hose

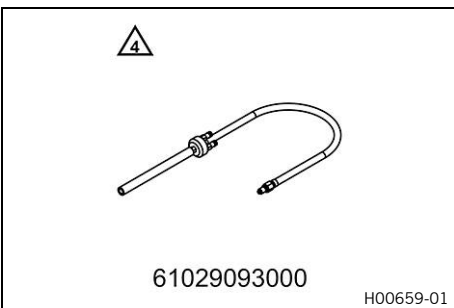

Art. no.: 61029093000

Pressure testing tool

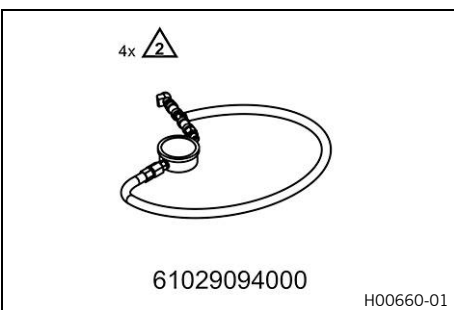

Art. no.: 61029094000

Engine work stand

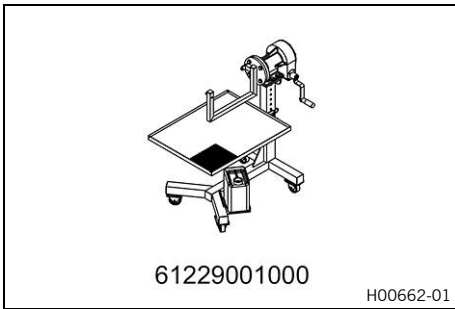

Art. no.: 61229001000

Pressing tool

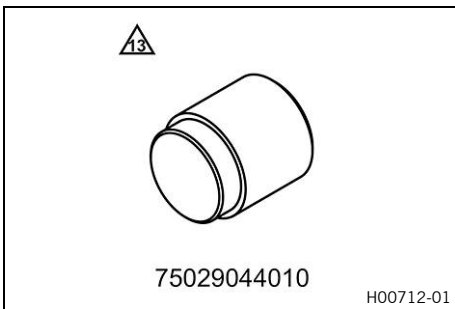

Art. no.: 75029044010

Crankshaft pressing tool

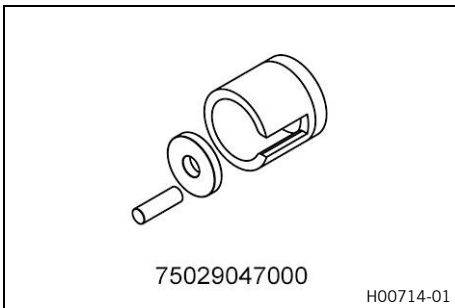

Art. no.: 75029047000

Lift stand



Art. no.: 78129955100

Feature

Height	315 ... 425 mm (12.4 ... 16.73 in)
Load	≤ 150 kg (≤ 331 lb.)

Footrest spring plier

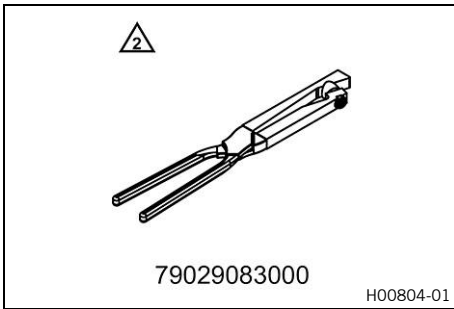

Art. no.: 79029083000

Pressing tool

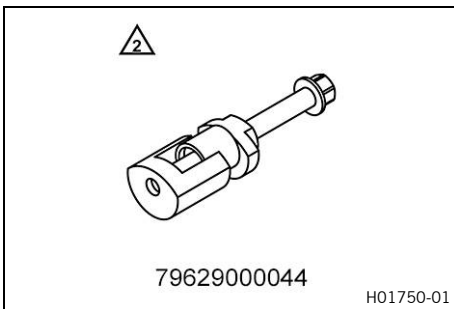

Art. no.: 79629000044

Holding wrench

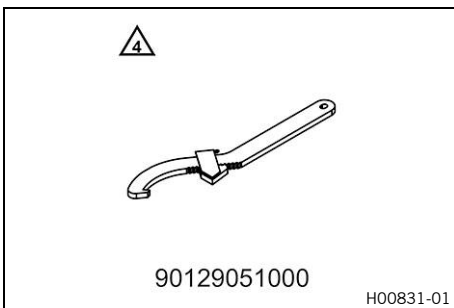

Art. no.: 90129051000

Spring hook

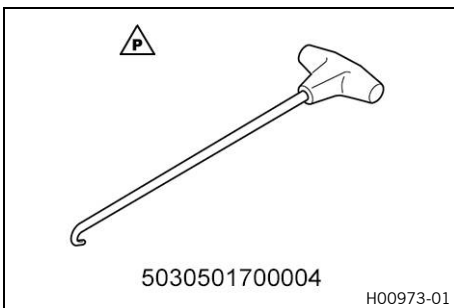

Art. no.: 5030501700004

Depth micrometer

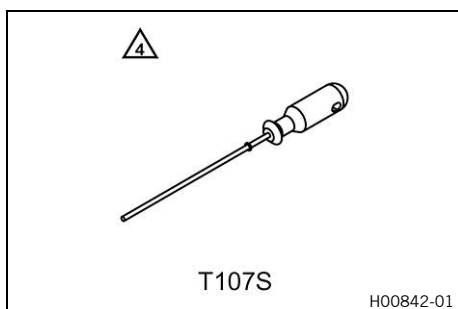

Art. no.: T107S

Drift

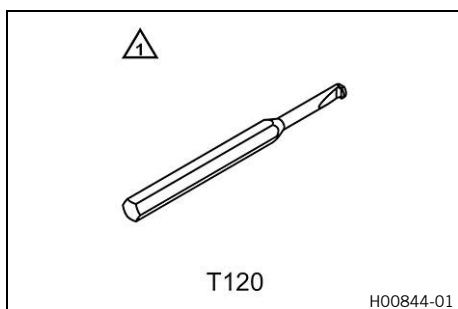

Art. no.: T120

Feature

Diameter	8 mm (0.31 in)
----------	----------------

Mounting sleeve

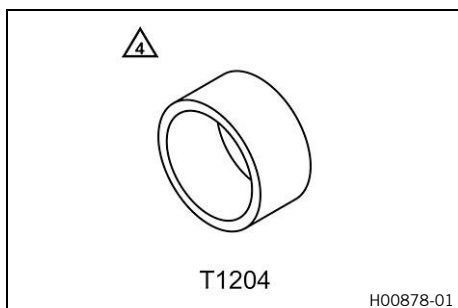

Art. no.: T1204

Feature

Diameter	25.5 ... 30.5 mm (1.004 ... 1.201 in)
----------	---------------------------------------

Calibrating unit

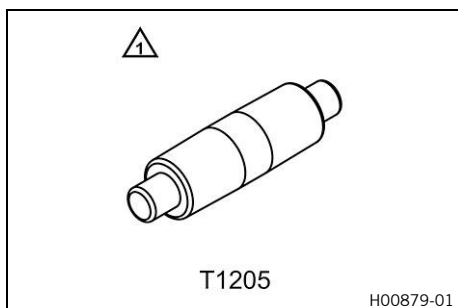

Art. no.: T1205

Feature

Diameter	18 mm (0.71 in)
----------	-----------------

Pressing tool

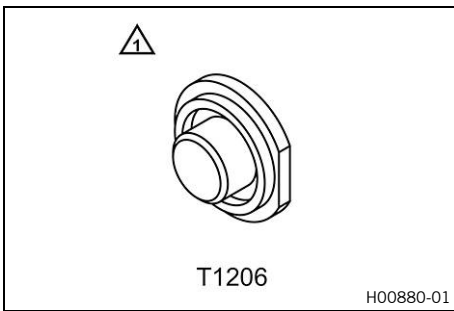

Art. no.: T1206

Feature

Diameter	15 ... 30 mm (0.59 ... 1.18 in)
----------	---------------------------------

Pressing tool

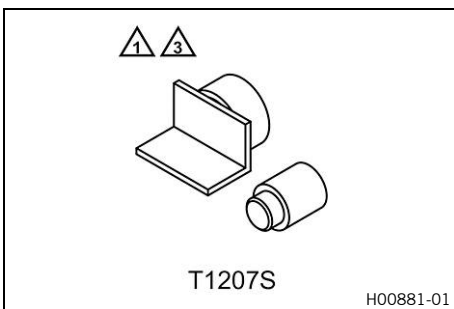

Art. no.: T1207S

Vacuum pump

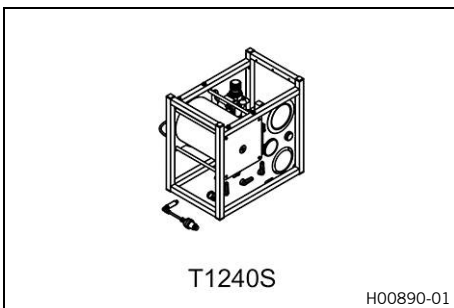

Art. no.: T1240S

Protecting sleeve

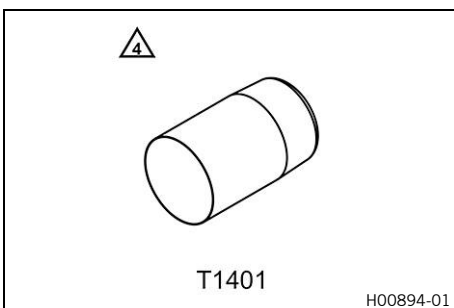

Art. no.: T1401

Feature

Diameter	48 mm (1.89 in)
----------	-----------------

Clamping stand

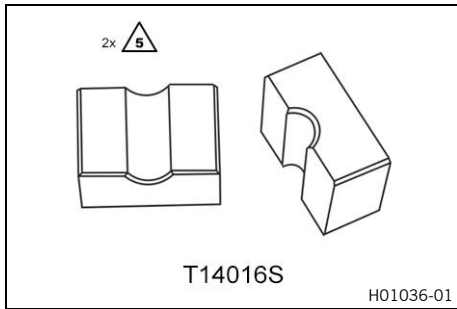

Art. no.: T14016S

Feature

Diameter	12 mm (0.47 in)
----------	-----------------

Ring wrench

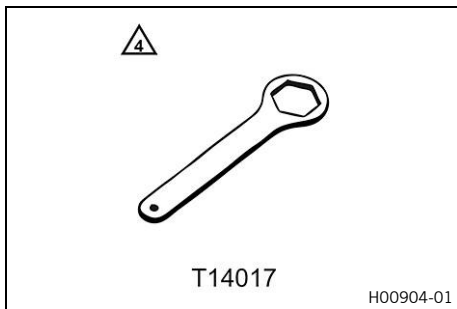

Art. no.: T14017

Feature

Hexagonal part	50 mm (1.97 in)
----------------	-----------------

Support tool

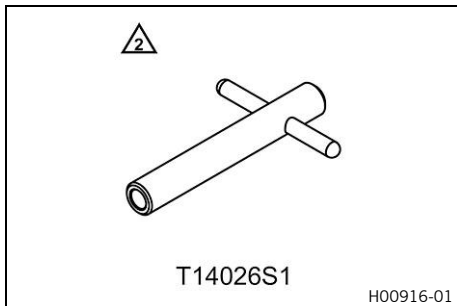

Art. no.: T14026S1

Feature

M12	
Diameter	17 mm (0.67 in)

Clamping stand

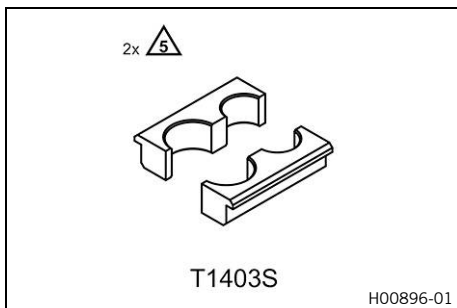

Art. no.: T1403S

Feature

Diameter	48 mm (1.89 in)
Diameter	60 mm (2.36 in)

Mounting tool

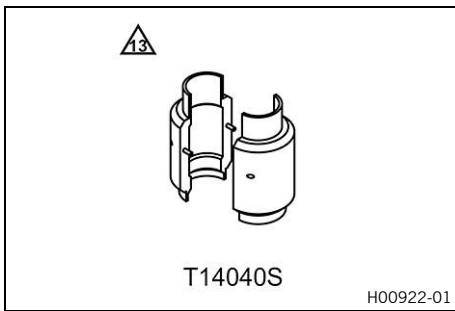

Art. no.: T14040S

Feature

Diameter	48 mm (1.89 in)
----------	-----------------

Special socket

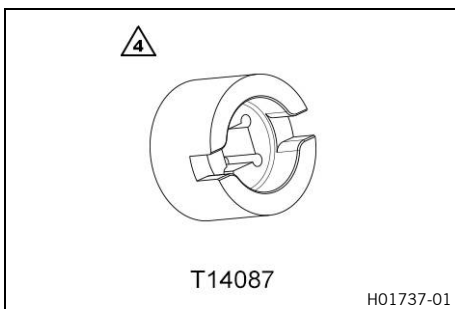

Art. no.: T14087

Feature

Drive	1/2 in
External diameter	44 mm (1.73 in)
Internal diameter	29.5 mm (1.161 in)

Pressing tool

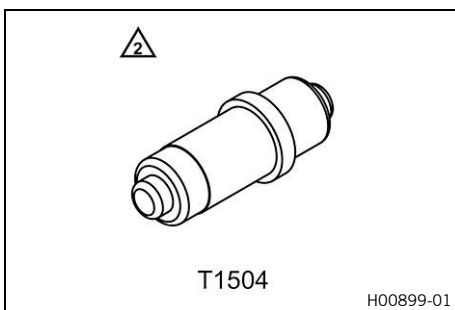

Art. no.: T1504

Feature

Diameter	18 mm (0.71 in)
----------	-----------------

Mounting tool

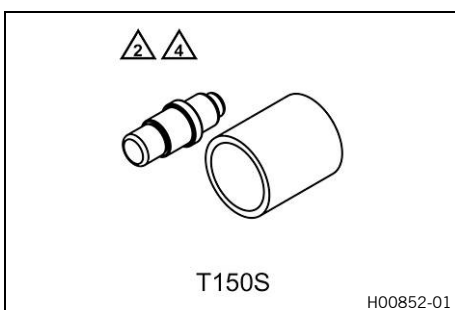

Art. no.: T150S

Mounting sleeve

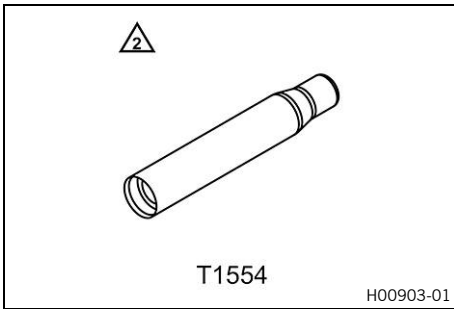

Art. no.: T1554

Feature

Diameter	18 mm (0.71 in)
----------	-----------------

Filling adapter

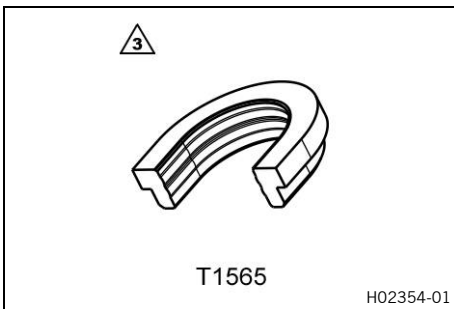

Art. no.: T1565

Filling tool

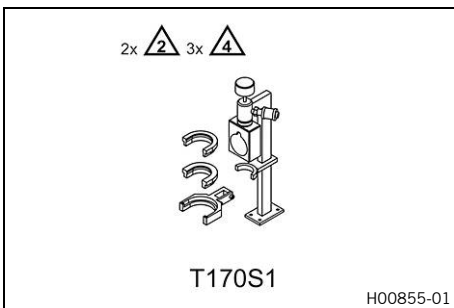

Art. no.: T170S1

JASO T903 MA2

Different technical development directions required a separate specification for motorcycles – the **JASO T903 MA2** standard.

Earlier, engine oils from the automobile industry were used for motorcycles because there was no separate motorcycle specification.

Whereas long service intervals are demanded for automobile engines, the focus for motorcycle engines is on high performance at high engine speeds.

In most motorcycle engines, the transmission and clutch are lubricated with the same oil.

The **JASO T903 MA2** standard meets these special requirements.

SAE

The SAE viscosity classes were defined by the Society of Automotive Engineers and are used for classifying oils according to their viscosity. The viscosity describes only one property of oil and says nothing about quality.

JASO FD

JASO FD is a classification for a 2-stroke engine oil that was specifically developed for the extreme demands of racing. Thanks to first rate synthetic esters and specially designed additives, superb combustion is achieved even under extreme operating conditions.

TPI	Injection into transfer ducts (Transfer Port Injection)	Electronic fuel injection in which two injection valves in the transfer ducts of the cylinders are used
PA	Preload adjuster	Device on the spring elements which enables adjustment of the spring preload

Art. no.	Article number
ca.	circa
cf.	compare
e.g.	for example
etc.	et cetera
i.a.	inter alia
no.	number
poss.	possibly

2

2-stroke oil level
checking 296

2-stroke oil tank cap
closing 297
opening 297

A

Accessories 9

Air filter
cleaning 118
installing 117
removing 117

Air filter box
cleaning 118
sealing 119

Air filter box cover
installing 116
preparing for securing 118
removing 116

Alternator
stator winding, checking 304

Ambient pressure
programming 310

Antifreeze
checking 286

Auxiliary substances 9

B

Battery
installing 162
negative cable, connecting 161
negative cable, disconnecting 160
recharging 163
removing 161

Brake disc
of front brake, changing 142
of rear brake, changing 146

Brake discs
checking 139

Brake fluid
front brake, adding 171
front brake, changing 172
of rear brake, adding 178
of rear brake, changing 179

Brake fluid level
front brake, checking 170
rear brake, checking 178

Brake linings
front brake, changing 167

front brake, checking 167
of rear brake, changing 174
rear brake, checking 174

C

Capacity
coolant 289, 315
fuel 316
Gear oil 202, 294, 315

Cartridge
of fork legs, disassembling 23, 46
of the fork legs, assembling 29, 52

Chain
checking 151
cleaning 149

Chain guide
checking 151

Chain tension
adjusting 153
checking 150

Characteristic map of the throttle response
adjusting 72

Charging voltage
checking 164

Chassis number 10

Clutch
checking 277
fluid level, checking/correcting 275
fluid, changing 276

Clutch lever
basic position, adjusting 69

Cold start button 311

Combination instrument
adjusting 186
battery, changing 184
overview 185
setting the clock 187
setting the kilometers or miles 185

Compression damping
fork, adjusting 14

Coolant
draining 287
refilling 288

Coolant level
checking 286-287

Cooling system 286

Crankshaft position sensor
checking 305

Cylinder - Nikasil® coating 232

D	
Diagnostics connector	166
Drivetrain kit	
changing	154
E	
Engine	
assembling	250
disassembling	203
installing	196
removing	190
technical data - engine	312
working on individual parts	219
Engine – work on the individual parts	
connecting rod, conrod bearing, and crank pin, changing	223
crankshaft bearing inner race, installing	222
crankshaft bearing inner race, removing	222
crankshaft run-out at the bearing pin, checking	224
cylinder, checking/measuring	224
engine case section, right	219
exhaust control, checking	227
exhaust control, removing	225
kick starter, checking	248
main shaft, disassembling	243
piston ring end gap, checking	233
piston, checking	232
piston, measuring	232
piston/cylinder, measuring the mounting clearance	233
reed valve housing, assembling	235
reed valve housing, disassembling	234
shift mechanism, checking	242
shift shaft, preassembling	241
stator, installing	308
transmission, checking	244
Engine – working on the individual parts	
clutch cover	237
clutch, checking	240
countershaft, assembling	246
countershaft, disassembling	244
cylinder - Nikasil [®] coating	232
electric starter drive, checking	249
engine case section, left	220
exhaust control, installing	229
intake flange, checking	235
main shaft, assembling	246
reed valve housing, checking	235
reed valve, checking	235
stator, removing	307
Engine assembly	
alternator cover, installing	272
balancer shaft, installing	257
clutch basket, installing	258
clutch cover, installing	261
clutch discs, installing	259
clutch push rod, installing	274
crankshaft, installing	250
cylinder head, installing	271
cylinder, installing	265
engine, removing from the engine work stand	274
gear oil drain plug, installing	273
intermediate kick starter gear, installing ...	256
kick starter shaft, installing	256
kick starter shaft, preassembling	248
kick starter, installing	272
left engine case section, installing	252
locking lever, installing	255
piston, installing	264
reed valve housing, installing	253
rotor, installing	255
shift drum locating unit, installing	256
shift drum, installing	252
shift forks, installing	251
shift lever, installing	274
shift rails, installing	252
shift shaft, installing	256
spacer, installing	273
starter motor, installing	254
transmission shafts, installing	251
water pump cover, installing	263
X-distance, adjusting	267
X-distance, checking	267
Z-distance, setting	269
Engine disassembly	
alternator cover, removing	204
balancer shaft, removing	212
clutch basket, removing	211
clutch cover, removing	209
clutch discs, removing	210
clutch push rod, removing	203
crankshaft, removing	218
cylinder head, removing	205
cylinder, removing	206
engine, clamping into the engine work stand	203
gear oil, draining	203
injection valves, installing	272
Injection valves, removing	205
intermediate kick starter gear, removing	213
kick starter shaft, removing	213
kick starter, removing	205
left engine case section, removing	217
locking lever, removing	214
piston, removing	208
reed valve housing, removing	216
rotor, removing	214

shift drum locating unit, removing	214	Front fender	
shift drum, removing	217	installing	134
shift forks, removing	218	removing	134
shift lever, removing	203	Front wheel	
shift rails, removing	217	installing	142
shift shaft, removing	214	removing	141
spacer, removing	204	Fuel filter	
starter motor, removing	215	changing	126
transmission shafts, removing	218	Fuel pressure	
water pump cover, removing	209	checking	132
Engine guard		Fuel pump	
installing	74	changing	129
removing	74	Fuel screen	
Engine number	10	changing	125
Engine sprocket		Fuel tank	
checking	151	installing	123
Exhaust control		removing	122
checking/adjusting	291	Fuse	
F		individual power consumers, changing	159
Figures	9	main fuse, changing	157
Filler cap		G	
closing	120	Gear oil	
opening	120	adding	295
Foot brake lever		changing	294
basic position, adjusting	177	Gear oil level	
free travel, checking	176	checking	295
Footrests		H	
changing	74	Hand brake lever	
Fork		basic position, adjusting	170
article number	10	free travel, adjusting	170
Fork legs		free travel, checking	169
assembling	33, 56	Handlebar position	67
bleeding	16	adjusting	67
cartridge, assembling	29, 52	Headlight	
cartridge, disassembling	23, 46	range, adjusting	184
checking	27, 50	Headlight bulb	
disassembling	20, 43	changing	182
dust boots, cleaning	17	Headlight mask with headlight	
fork, servicing	20, 43	installing	135
installing	18	removing	135
of tap compression, disassembling	26, 49	Headlight setting	
of the tap compression, assembling	28	checking	183
of the tap compression, assembling the	51	Heim joint	
removing	17	checking	101
spring preload, adjusting	16	on the swingarm, changing	103
Fork protector		High-speed compression damping	
installing	19	shock absorber, adjusting	78
removing	19		
Frame			
checking	74		

I	
Idle speed	
adjusting	310
Ignition coil	
primary winding, checking	303
Ignition system	
checking	302
Ignition timing map	
plug-in connector	157
Implied warranty	9
L	
Lower triple clamp	
installing	38, 62
removing	37, 61
Low-speed compression damping	
shock absorber, adjusting	78
M	
Main fuse	
changing	157
Main silencer	
glass fiber yarn filling, changing	114
installing	114
removing	113
Manifold	
installing	112
removing	111
Motorcycle	
cleaning	322
raising with lift stand	12
removing from lift stand	12
O	
Oil pump	
priming	298
replacing	299
Open-circuit current	
checking	165
Operating substances	9
P	
Play in throttle cable	
adjusting	71
Preparing for use	
after storage	325
R	
Rear sprocket	
checking	151
Rear wheel	
installing	145
removing	144
Rebound damping	
fork, adjusting	15
shock absorber, adjusting	79
Refueling	
2-stroke oil	297
Riding sag	
adjusting	82
Rim run-out	
checking	139
Rubber grip	
checking	70
S	
Seat	
mounting	121
removing	121
Service schedule	326-329
Servicing the fork	20, 43
Servicing the shock absorber	83
Shock absorber	
article number	11
damper, assembling	94
damper, bleeding and filling	96
damper, checking	89
damper, disassembling	85
damper, filling with nitrogen	99
heim joint, changing	102
heim joint, installing	91
heim joint, removing	90
installing	83
pilot bushing, replacing	88
piston rod, assembling	92
piston rod, disassembling	87
removing	83
riding sag, checking	81
seal ring retainer, assembling	91
seal ring retainer, disassembling	86
shock absorber, servicing	83
spring preload, adjusting	81
spring, installing	100
spring, removing	84
static sag, checking	80
Spare parts	9
Spark plug	
changing	306
Spark plug and spark plug connector	
changing	307

Spark plug connector		
checking	304
Speedometer		
additional functions, activating	187
wheel circumference, setting	188
Spoke tension		
checking	140
Starter motor		
checking	309
Starter relay		
checking	165
Starting	12-13
Steering head bearing		
changing	40, 64
lubricating	37, 61
Steering head bearing play		
adjusting	42, 66
checking	42, 65
Storage	324
Swingarm		
checking	101
installing	106
removing	105
Swingarm bearing		
changing	108
checking	105
T		
Tap compression		
of fork legs, assembling	28, 51
of fork legs, disassembling	26, 49
Technical data		
capacities	315
chassis	316
chassis tightening torques	319
electrical system	317
engine - tolerance, wear limits	313
engine tightening torques	314
fork	317
shock absorber	318
tires	317
Throttle cable play		
checking	71
Throttle cable routing		
checking	70
Tire air pressure		
checking	137
Tire condition		
checking	137
Turn signal bulb		
changing	182
Type label	10
W		
Warranty	9
Wheel bearing		
checking	138
of the front wheel, changing	143
of the rear wheel, changing	147
Winter operation		
checks and maintenance steps	323
Wiring diagram	330-357
Page 1 of 6	346
Page 1 of 8	330
Page 2 of 6	348
Page 2 of 8	332
Page 3 of 6	350
Page 3 of 8	334
Page 4 of 6	352
Page 4 of 8	336
Page 5 of 6	354
Page 5 of 8	338
Page 6 of 6	356
Page 6 of 8	340
Page 7 of 8	342
Page 8 of 8	344
Work rules	8



3206345en

04/2018

